

# Power Distribution and Protection

Circuit Protection

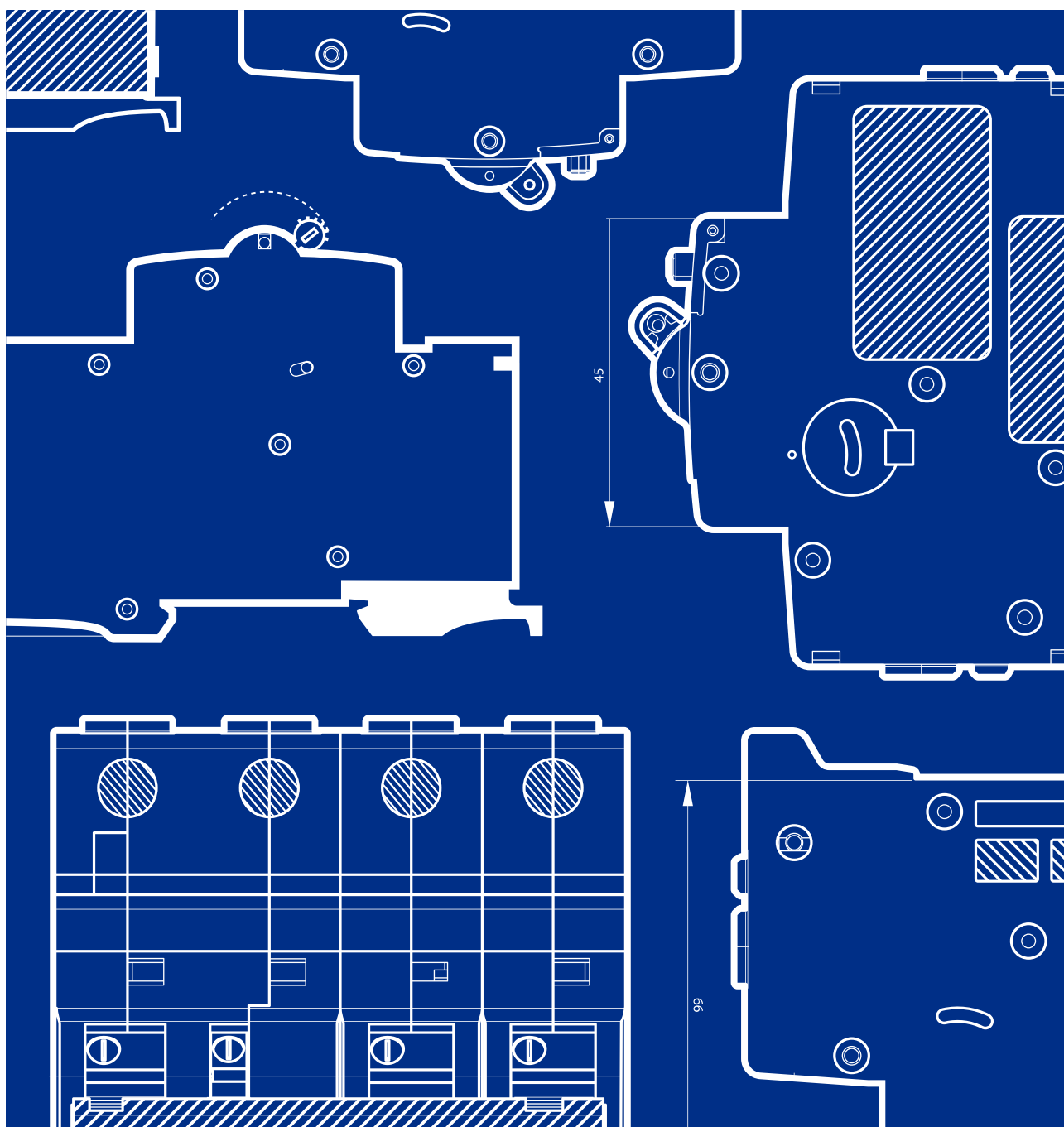

MCBs and RCBOs

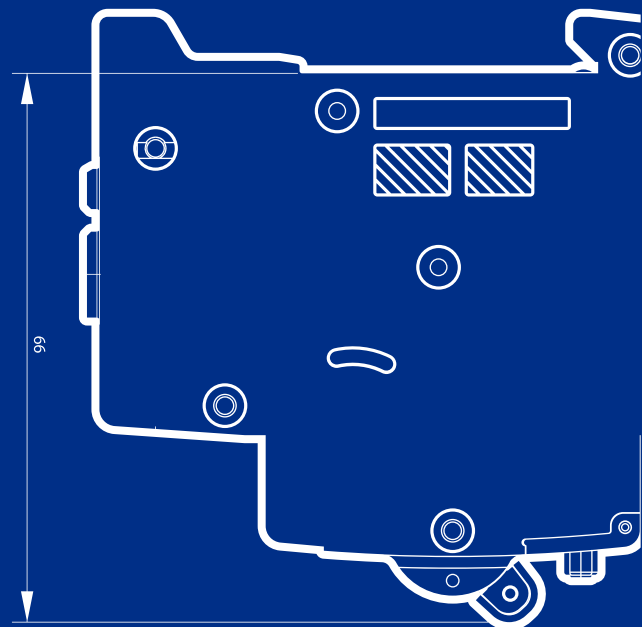
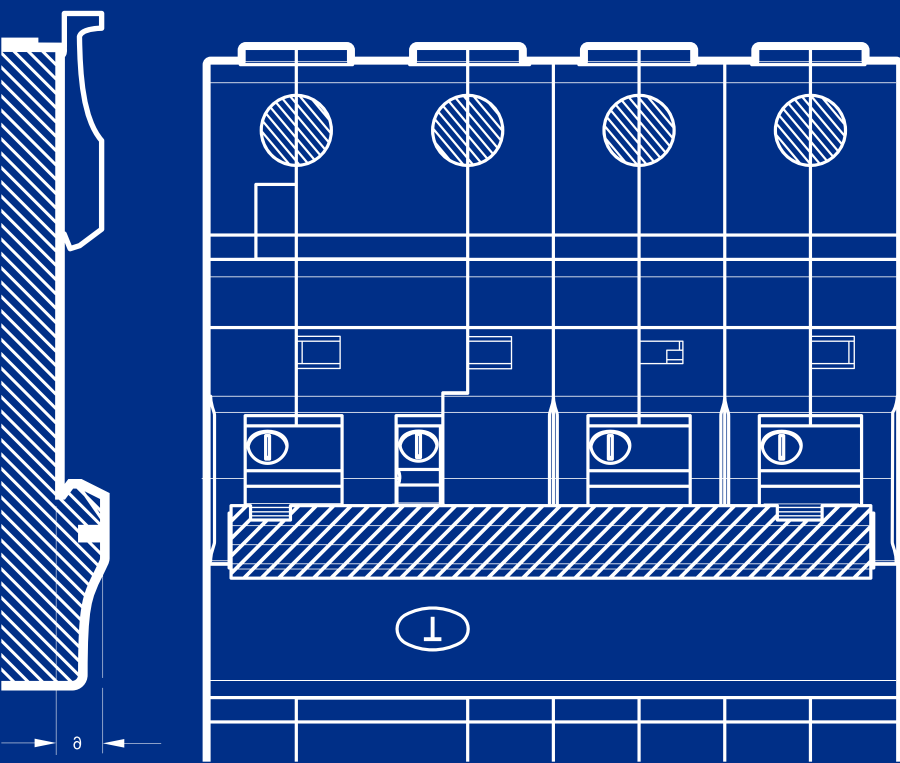
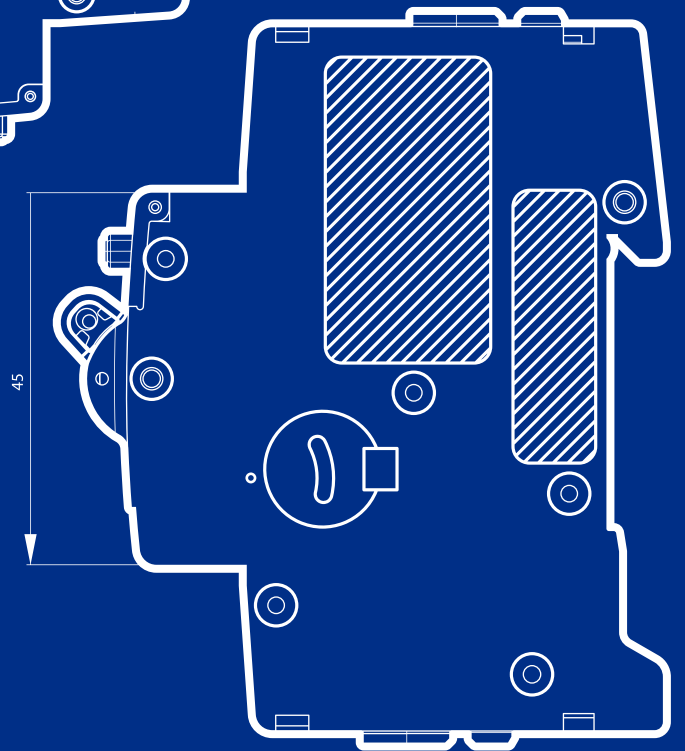
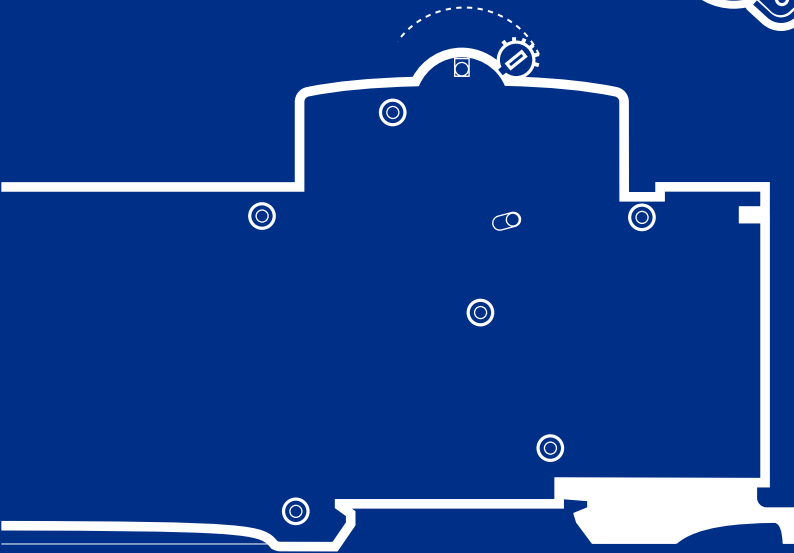
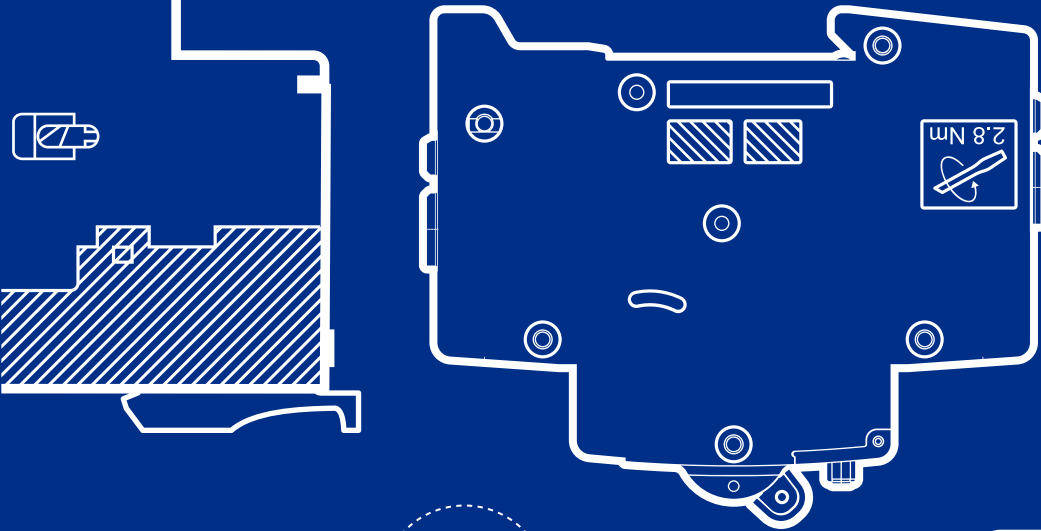
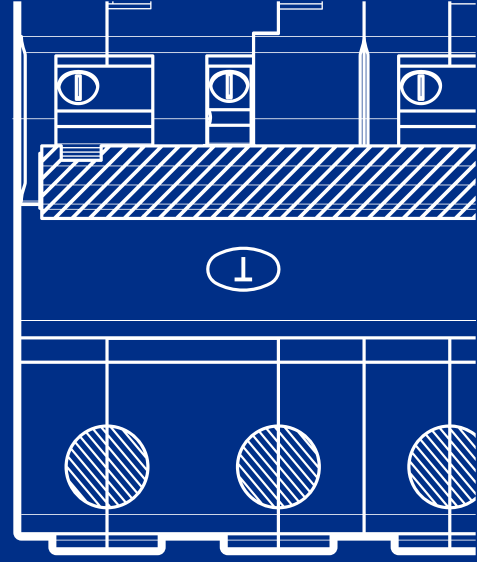
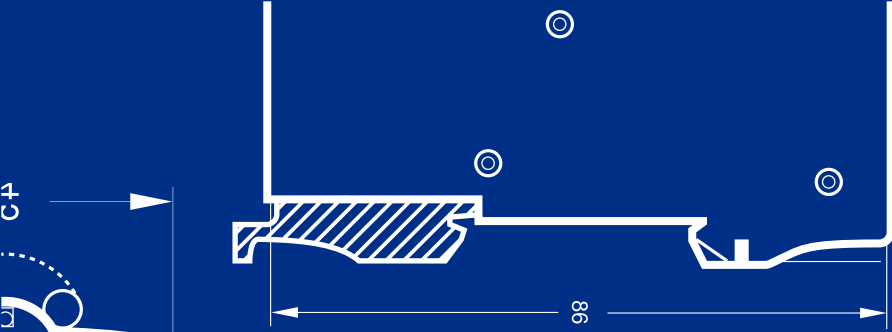

# 1 Miniature Circuit Breakers (MCBs) and Residual Current Breakers with Overcurrent (RCBOs)

Miniature Circuit Breakers Selection Guide	4
MOD6 Residual Current Devices Selection Guide	6
DIN-Safe Residual Current Devices Selection Guide	8
MOD6 MCB Accessories	16
MOD6 RCBB / RCBO Accessories	45
DIN-T MCB Accessories	101
DIN-T RCBO Accessories	141
DIN-T Add-on Modules	151

## Miniature Circuit Breakers Selection Guide

### MOD6



### DIN-T6



### DIN-T10



Application	Residential / Light Commercial	Commercial / Industrial	Commercial / Industrial
Standard	AS / NZS 60898	AS / NZS 60898 AS / NZS 60947-2	AS / NZS 60898 AS / NZS 60947-2
Number of Poles and Module Width	1P - 18 mm 2P - 36 mm 3P - 54 mm	1P - 18 mm 2P - 36 mm 3P - 54 mm	1P - 18 mm 2P - 36 mm 3P - 54 mm 4P - 72 mm
Mounting	DIN Rail	DIN Rail	DIN Rail
Current Ratings	6 A - 63 A	2 A - 63 A	0.5 A - 63 A
Short Circuit Rating	6 kA	6 kA	10 kA
Curve Types	C	C & D	B, C & D
Rated AC Voltage 1P / 2, 3, 4	240 / 415 V	240 / 415 V	240 / 415 V
Rated DC Voltage	48 V 1P 110 V 2P series	48 V 1P 110 V 2P series	48 V 1P 110 V 2P series
Sealable In On-off Position	Yes	Yes	Yes
Trip-free Mechanism	Yes	Yes	Yes
Padlock Facility	Non Captive	Yes	Yes
	Captive	No	Yes
Busbar Connection	On-top	Pin	Pin
	Off-bottom	Fork / Pin	Fork / Pin
Terminal Size	On-top	25 mm <sup>2</sup>	35 mm <sup>2</sup>
	Off-bottom	25 mm <sup>2</sup>	35 mm <sup>2</sup>

**DIN-T15****DIN-T10H****DIN-T 2-in-1****DIN-T DC****DIN-T Easy-Fit**

Commercial / Industrial	Commercial / Industrial	Commercial / Industrial	Commercial / Industrial	Commercial / Industrial
AS / NZS 60947-2	AS / NZS 60898 AS / NZS 60947-2	AS / NZS 60898 AS / NZS 60947-2	AS / NZS 60898 AS / NZS 60947-2	AS / NZS 60898 AS / NZS 60947-2
1P - 18 mm 2P - 36 mm 3P - 54 mm 4P - 72 mm	1P - 27 mm 2P - 53 mm 3P - 80 mm 4P - 106 mm	1P + 1P - 18 mm 2P - 18 mm 3P - 36 mm 4P - 36 mm	1P - 27 mm 2P - 54 mm 4P - 81 mm	1P - 36 mm 3P - 54 mm
DIN Rail	DIN Rail	DIN Rail	DIN Rail	DIN Rail
0.5 A - 63 A	80 A - 125 A	2 A - 40 A	0.5 A - 63 A	6 A - 63 A
15 kA - 50 kA	10 kA	6 kA	6 kA T15	6 kA
C	B, C & D	C	B & C	C
240 / 415 V	240 / 415 V	240 / 415 V	240 / 415 V	240 / 415 V
48 V 1P 110 V 2P series	125 V 1P 250 V 2P 375 V 3P 500 V 4P	-	250 V 1P 500 V 2P 880 V 4P series	-
Yes	Yes	Yes	Yes	Yes
Yes	Yes	Yes	Yes	Yes
Yes	Yes	Yes	Yes	Yes
Yes	Yes	No	Yes	No
Pin	Pin	Pin	Pin	-
Fork / Pin	Pin	Pin	Fork / Pin	Pin
35 mm <sup>2</sup>	70 mm <sup>2</sup>	16 mm <sup>2</sup>	35 mm <sup>2</sup>	4 mm <sup>2</sup> 6 A - 20 A 35 mm <sup>2</sup> 25 A - 63 A
35 mm <sup>2</sup>	70 mm <sup>2</sup>	16 mm <sup>2</sup>	35 mm <sup>2</sup>	35 mm <sup>2</sup>
<b>94</b>	<b>88</b>	<b>57</b>	<b>72</b>	<b>65</b>

## MOD6 Residual Current Devices Selection Guide

### MOD6RCCB



### MOD6RCBO1



### M6RCBS



<b>Application</b>		Residential / Light Commercial	Light Commercial	Residential / Light Commercial
<b>Standard</b>		AS / NZS 61008-1	AS / NZS 61009-1	AS / NZS 61009-1
<b>Number of Poles and Module Width</b>		2P - 36 mm 4P - 72 mm	1P + N - 18 mm	1P + N - 18 mm
<b>Mounting</b>		DIN Rail	DIN Rail	DIN Rail
<b>Current Ratings</b>		40 A, 63 A	10 A, 16 A, 20 A, 25 A, 32 A	6 A, 10 A, 16 A, 20 A, 25 A, 32 A
<b>Trip Sensitivity</b>		30 mA	30 mA	10 mA, 30 mA
<b>Sensitivity Type</b>		AC & A	A	A
<b>Switched Neutral</b>		Yes	No	Yes
<b>Short Circuit Rating</b>		-	6 kA	6 kA
<b>Curve Types</b>		-	C	C
<b>Rated AC Voltage 1P / 2, 3, 4P</b>		240 / 415 V	240 V	240 V
<b>Sealable In On-off Position</b>		Yes	Yes	No
<b>Terminal Size</b>	<b>On-top</b>	50 mm <sup>2</sup>	25 mm <sup>2</sup>	16 mm <sup>2</sup>
	<b>Off-bottom</b>	50 mm <sup>2</sup>	25 mm <sup>2</sup>	25 mm <sup>2</sup>
<b>Page Number</b>		<b>20</b>	<b>24</b>	<b>29</b>

**M6RCBD****MOD6RCBO2**

Residential / Light Commercial Residential / Light Commercial

AS / NZS 61009-1 AS / NZS 61009-1

1P + N - 18 mm 2P - 36 mm

DIN Rail DIN Rail

6 A, 10 A, 16 A, 20 A,  
25 A, 32 A 10 A, 16 A, 20 A, 25 A,  
32 A, 40 A

10 mA, 30 mA 10 mA, 30 mA

A AC &amp; A

Yes Yes

6 kA 6 kA

C C

240 V 240 V

No No

16 mm<sup>2</sup> 25 mm<sup>2</sup>16 mm<sup>2</sup> 25 mm<sup>2</sup>**34****39**

## DIN-Safe Residual Current Devices Selection Guide

### DIN-Safe DSRCD



### DIN-Safe DSRCBS



### DIN-Safe DSRCBH



<b>Application</b>		Commercial / Industrial	Commercial / Industrial	Commercial / Industrial
<b>Standard</b>		AS / NZS 61008	AS / NZS 61009	AS / NZS 61009
<b>Number of Poles and Module Width</b>		2P - 36 mm 4P - 72 mm	1P + N - 18 mm	1P + N - 18 mm
<b>Mounting</b>		DIN Rail	DIN Rail	DIN Rail
<b>Current Ratings</b>		40 A, 63 A, 80 A, 100 A, 125 A	6 A, 10 A, 16 A, 20 A, 25 A, 32 A	6 A, 10 A, 16 A, 20 A, 25 A, 32 A, 40 A
<b>Trip Sensitivity</b>		30 mA, 100 mA, 300 mA, 500 mA	10 mA, 30 mA	10 mA, 30 mA, 100 mA
<b>Sensitivity Type</b>		A, AI, S, F, B	A	A
<b>Switched Neutral</b>		Yes	Yes	No
<b>Short Circuit Rating</b>		Inc - 10 kA MCB or fuse backup	6 kA	6 kA, 10 kA
<b>Curve Types</b>		-	B & C	C & D
<b>Rated AC Voltage</b>		240 V / 415 V	240 V	240 V
<b>Sealable In On-off Position</b>		Yes	Yes	Yes
<b>Trip-free Mechanism</b>		Yes	Yes	Yes
<b>Padlock Facility</b>	<b>Non Captive</b>	Yes	Yes	Yes
	<b>Captive</b>	No	No	Yes
<b>Busbar Connection</b>	<b>On-top</b>	Pin	-	-
	<b>Off-bottom</b>	Fork / Pin	Pin	Fork / Pin
<b>Terminal Size - On-top</b>		50 mm <sup>2</sup>	16 mm <sup>2</sup>	25 mm <sup>2</sup>



### DIN-Safe DSRCB



### DIN-Safe DSRCB-P



### DIN-Safe DSRCM



### DIN-Safe Easy-Fit



Commercial / Industrial

Commercial / Industrial

Commercial / Industrial

Commercial / Industrial

AS / NZS 61009

AS / NZS 61009

AS 3190

AS / NZS 61008

2P - 36 mm

2P - 36 mm

1P + N  
3P & 3P + N } Refer to dimension diagrams2P - 36 mm  
4P - 72 mm

DIN Rail

DIN Rail

DIN Rail

DIN Rail

6 A, 10 A, 16 A, 20 A,  
25 A, 32 A, 40 A6 A, 10 A, 16 A, 20 A,  
25 A, 32 A, 40 A

32 A, 63 A

40 A, 63 A

10 mA, 30 mA, 100 mA

10 mA, 30 mA

30 mA, 100 mA, 300 mA

30 mA

A, AI

AC

AC, A

AC

Yes

No

-

Yes

6 kA, 10 kA

10 kA

-

Inc - 10 kA MCB or  
fuse backup

C

C

-

-

110 / 240 V Type A  
240 V Type AI

240 V

240 V / 415 V

240 V / 415 V

Yes

Yes

No

Yes

Yes

Yes

Yes

Yes

Yes

Yes

No

Yes

Yes

Yes

No

No

Pin

-

-

-

Fork / Pin

Fork / Pin

-

Pin

25 mm<sup>2</sup>25 mm<sup>2</sup>32 A - 16 mm<sup>2</sup>  
63 A - 25 mm<sup>2</sup>50 mm<sup>2</sup>

122

122

132

137

# MOD6 6kA MCB



- ✓ Complies with AS/NZS 60898
- ✓ MOD6 MCBs feature 6 kA short circuit rating
- ✓ C curve tripping characteristic
- ✓ Pad lockable and sealable toggle restricts unauthorised action
- ✓ Free tripping mechanism even if toggle is locked or sealed ON or OFF
- ✓ Fast connection pin / fork busbar comb or busbar chassis
- ✓ Suits pole-covers, loadcentres and Concept One Panelboards
- ✓ Approval No. N17481 or RCM
- ✓ For general purpose light and power applications
- ✓ NHP MOD6 MCBs offering core range of quality 6 kA circuit protection that has been tested to local standards and holds Australian and New Zealand approvals



## General

Tripping Characteristics	C
Nominal Current Rating at 30 °C	6 - 63 A
Poles	1P / 2P / 3P
Neutral Pole Protected	No

## Short Circuit

Icn 230 / 400 V 1P / 2P / 3P	6 / 6 / 6 kA
------------------------------	--------------

## Voltage

Nominal Voltage Un	AC	1P	240, 415 V AC
		3P / 4P	415 V AC
	DC	1P	48 V DC
		2P (In Series)	110 V DC
Frequency	50 / 60 Hz		
Maximum Service Voltage U <sub>max</sub>	250 / 440 V AC 53 / 120 V DC		
Minimum Service Voltage U <sub>min</sub>	12 V AC		

## Connections

Maximum Cable Size	Rigid / Flexible (Top)	25 mm <sup>2</sup> / 25 mm <sup>2</sup>
	Rigid / Flexible (Bottom)	35 mm <sup>2</sup> / 25 mm <sup>2</sup>



## Application



Residential, domestic and light commercial general light and power applications. Suitable for use in MOD6 pole-covers, MOD6 loadcentres and Concept One Panelboards.

## Dimensions

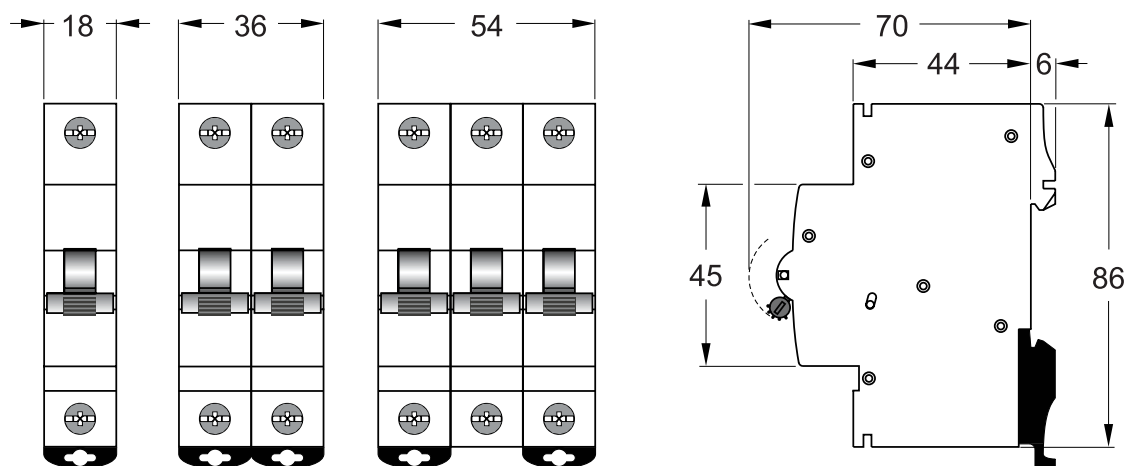



1 Pole

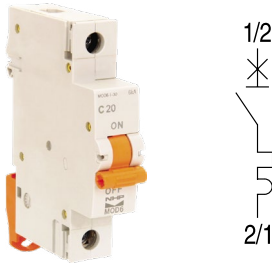

2 Pole

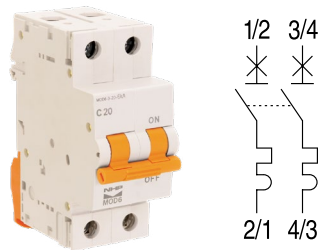

3 Pole

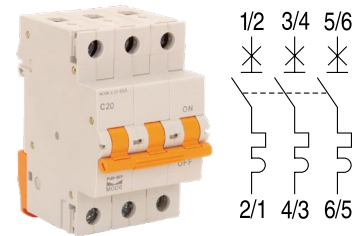

Width

18 mm

36 mm

54 mm

Amps (In)

C-Curve (5-10 In)

C-Curve (5-10 In)

C-Curve (5-10 In)

6	MOD6106	MOD6206	MOD6306
10	MOD6110	MOD6210	MOD6310
16	MOD6116	MOD6216	MOD6316
20	MOD6120	MOD6220	MOD6320
25	MOD6125	MOD6225	MOD6325
32	MOD6132	MOD6232	MOD6332
40	MOD6140	MOD6240	MOD6340
50	MOD6150	MOD6250	MOD6350
63	MOD6163	MOD6263	MOD6363

## Voltage Ratings

Nominal Voltage $U_n$	AC	1P	240, 415 V AC
		3P / 4P	415 V AC
	DC	1P	48 V DC
		2P (in series)	110 V DC
Frequency	50 / 60 Hz		
	DC : 1.4 x mag. trip		
	400 Hz : 1.5 x mag. trip		
Maximum Service Voltage $U_{bmax}$	250 / 440 V AC 53 / 120 V DC		
Minimum Service Voltage $U_{bmin}$	12		
Selectivity Class (IEC 60898)	A		
Isolator Application	IEC 60947-2	Yes	
Rated Insulation Voltage	Pollution Degree 2	500 V	
	Pollution Degree 3	440 V	
Impulse Withstand Test Voltage	6 kV		
Insulation Resistance	10000 mOhm		
Dielectric Rigidity	2.5 kV		

## Environmental

Vibration Resistance (IEC 77 / 16.3) (in x, y, z direction)	3 g	
Endurance	Electrical at $U_n, I_n$	10000 cycles
	Mechanical	20000 cycles
Utilisation Category (IEC 60947-2)	A	
Protection Degree	Outside	IP20
	Inside	IP40
Self-extinguish Degree (According to UL94)	UL 94 V-2	
Tropicalisation (IEC60068-2 / DIN 40046)	+55 °C / 95 % RH	
Operating Temperature	-25 °C / +55 °C	
Storage Temperature	-55 °C / +55 °C	

## Connection

Rigid Cable Min / Max (Top)	1 mm <sup>2</sup> / 25 mm <sup>2</sup>	
Flexible Cable Min / Max (Top)	0.75 mm <sup>2</sup> / 25 mm <sup>2</sup>	
Rigid Cable Min / Max (Bottom)	1 mm <sup>2</sup> / 35 mm <sup>2</sup>	
Flexible Cable Min / Max (Bottom)	0.75 mm <sup>2</sup> / 25 mm <sup>2</sup>	
Torque (Top / Bottom)	4.5 / 4.5 Nm	
Busbar	Connection Top	Fork / Pin
	Connection Bottom	Fork / Pin

## Physical

Dimensions (H x W x D)	1P	86 x 18 x 76 mm
	2P	86 x 36 x 76 mm
	3P	86 x 54 x 76 mm
Weight	0.12 / 0.24 / 0.36 kg	
Package	12 / 6 / 4 module	



### Short-Circuit Capacity AC

IEC 60898	Icn	1P	230 / 400 V	6
		2P	230 / 400 V	6
		3P / 4P	230 / 400 V	6
Ics (Service)		% Icn		100
IEC 60947-2	Icu (Ultimate)	1P	127 V	15
			240 V	10
			415 V	6
		2P	127 V	30
			240 V	20
			415 V	10
	3P / 4P	240 V	20	
		415 V	10	
		440 V	6	
	Ics (Service)		% Icu	
NEMA AB1 (120 / 240 V)				-

### C-Curve Characteristics

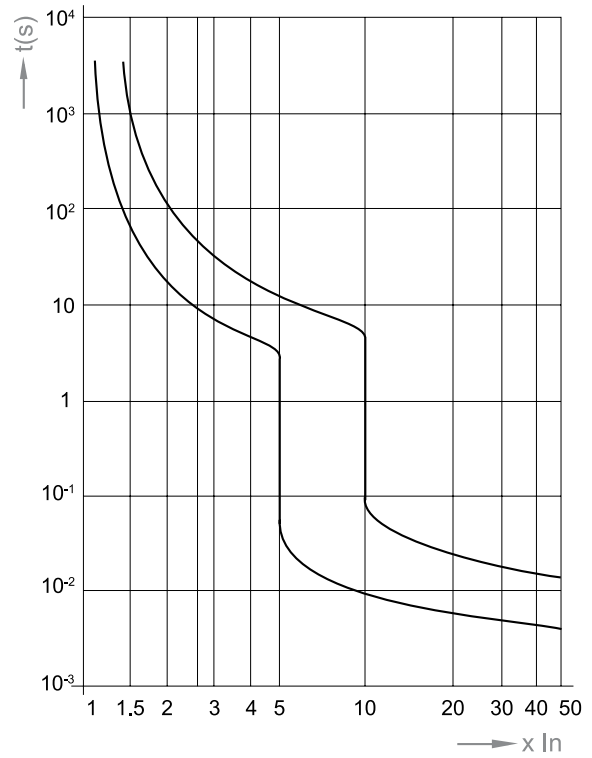

### Short-Circuit Capacity DC

IEC 60947-2	Icu (Ultimate)	1P	$\leq 60$ V	20
			$\leq 220$ V	-
		2P	$\leq 125$ V	25
			$\leq 440$ V	-
Ics (Service)		% Icu		100

### Let-through Energy $I^2t$ (A<sup>2</sup>s) C-Curve

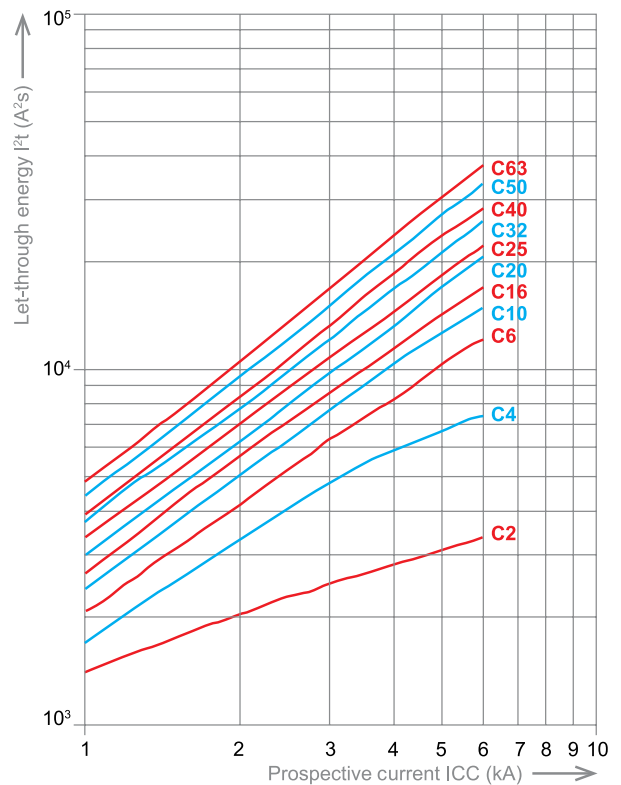



## Limited Peak Current (kA) at 230 / 400V C-Curve

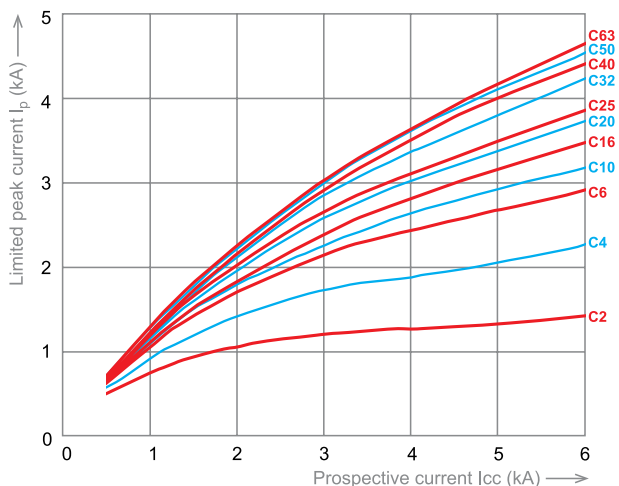

## Power Loss

$I_n$ (A)	Voltage Drop (V)	Energy Loss $P_w$ (W)	Resistance $Z$ (mOhm)
6	0.26	1.57	43.60
8	0.16	1.24	19.40
10	0.16	1.56	15.60
13	0.16	2.01	11.90
16	0.16	2.57	10.10
20	0.14	2.76	6.90
25	0.13	3.19	5.10
32	0.10	3.07	3.00
40	0.10	4.00	2.25
50	0.19	4.5	1.80
63	0.08	5.16	1.30

## Ambient Temperature Influence

0,5 - 6A

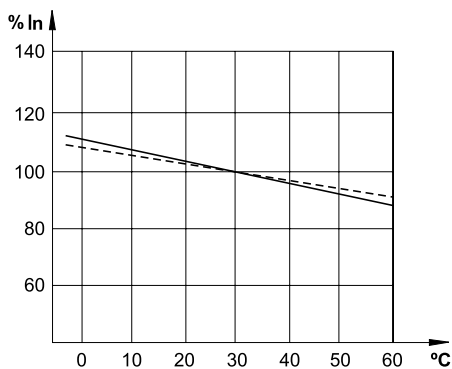

10A

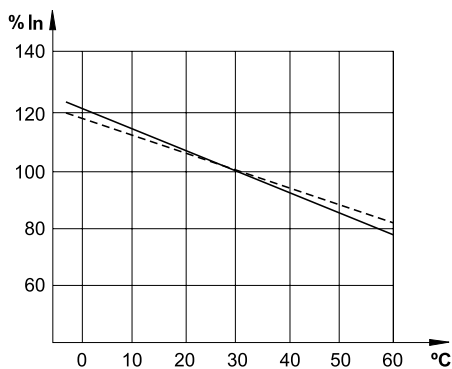

16 - 40A

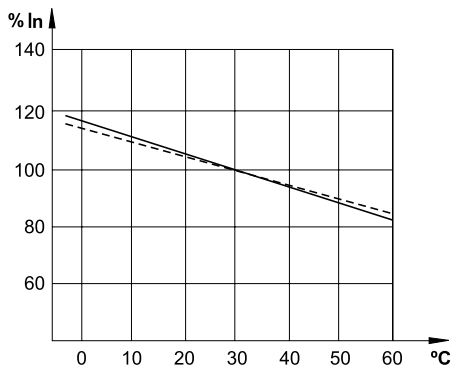

50 - 63A

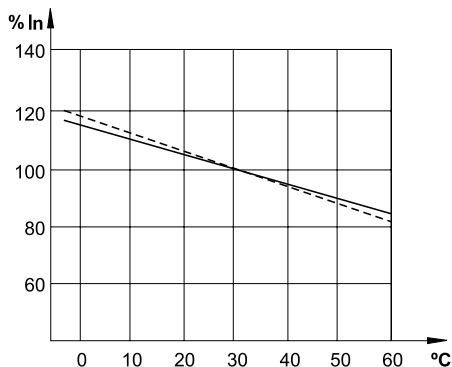

— : 1P (Single pole)  
 - - - : mP (Multipole)



## MOD6 Main Switch

### 1P, 2P and 3P Main Switches

Main Switch to isolate incoming supply or outgoing loads up to 100 A.



Item Description	Catalogue No.
MOD6 Main Switch, DIN Rail, 1P, 80 A	MOD6MS180
MOD6 Main Switch, DIN Rail, 1P, 100 A	MOD6MS1100



Item Description	Catalogue No.
MOD6 Main Switch, DIN Rail, 2P, 100 A	MOD6MS2100



Item Description	Catalogue No.
MOD6 Main Switch, DIN Rail, 3P, 100 A	MOD6MS3100



## Busbar Comb

### IBC, ICL and IBD Busbar Comb

Suitable for linking MOD6 Main Switches, MCBs and RCBOs in MOD6 pole-covers and MOD6 loadcentres. ICL and IBC are suited for regular 18 mm pitch terminals on MSW, MCBs and RCBOs. IBD is suited for 9 mm pitch terminals on 2-in-1 MCBs and M6RCBD RCBOs. Fork Type comb goes under the terminal screw head and Pin Type into the devices main terminal.

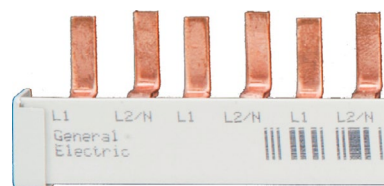
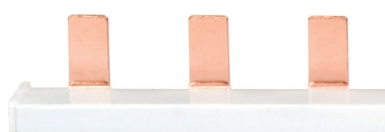

Item Description	Catalogue No.
Busbar Comb, 12 way, 100 A, 1P, Pin type with end caps	IBC112P
Busbar Comb, 15 way, 100 A, 1P, Pin type with end caps	IBC115P
Busbar Comb, 18 way, 100 A, 1P, Pin type with end caps	IBC118P

Item Description	Catalogue No.
Busbar Comb, 18 way, 1P+N, 80 A / 100 A, suits M6RCBD and DTCBD	IBD218P
Busbar Comb, 55 way, 1P+N, 80 A / 100 A, suits M6RCBD and DTCBD	IBD255P

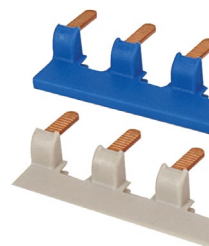
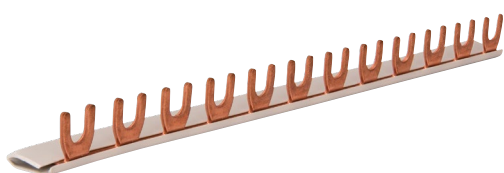

Item Description	Catalogue No.
Busbar Comb, 4 way, 1P, 80 A / 130 A, Fork type	ICL41F
Busbar Comb, 12 way, 1P, 90 A / 150 A, Fork type	ICL121F
Busbar Comb, 18 way, 1P, 80 A / 130 A, Fork type	ICL181F
Busbar Comb, 56 way, 1P, 110 A / 130 A, Fork type	ICL561F
Busbar Comb, 57 way, 3P, 110 A / 130 A, Fork type	ICL573F

Item Description	Catalogue No.
Busbar Comb Kit (blue and grey), 13 way, 63 A, 1P+N, suits M6RCBD	IBD213P



## Busbar Comb End Caps

### IBC and IBD Busbar End Caps

End caps to cover the end of cut busbar comb.



Item Description	Catalogue No.
Buscomb End Cap to suit 1P IBC	IBCEC1
Buscomb End Cap to suit 2P IBD	IBDEC2
Buscomb End Cap to suit 4P IBD	IBDEC4

## General Accessories

### Pole Filler, Lock Dogs and Terminals

Lock Dog to securely lock off devices. Pole filler to cover unused spaces in loadcentres and Panelboards. Terminal pins to allow connection of larger cables or multiple cables to a terminal.



Item Description	Catalogue No.
DIN Lock Dog, Non-Captive suits hasp up to 8.0 mm.	DTLD



Item Description	Catalogue No.
DIN Pole Filler (1 strip of 4 poles, 8 x 9 mm segments)	DTPF



Item Description	Catalogue No.
Terminal 3 x 16 mm neutral link to suit RCCB	DTTAX16PN3



Item Description	Catalogue No.
Terminal Pin 25 mm to suit DIN MCBs	DTTLT25PN2

# MOD6 RCCBs (Safety Switches)



- ✓ Complies with AS/NZS 61008 (RCCBs)
- ✓ MOD6 RCCBs feature 6 kA conditional short circuit rating
- ✓ 1P+N and 3P+N for single or three phase loads
- ✓ Type AC or Type A RCD option
- ✓ 30 mA sensitivity featured as standard simplifying the selection for personnel protection applications
- ✓ Fast connection pin / fork busbar comb or busbar chassis
- ✓ Suits pole-covers and loadcentres
- ✓ Approval No. NSW17482 or RCM Mark



## General

Sensitivity $I_{\Delta n}$	30 mA
RCD Type	A, AC
Nominal Current Rating at 30 °C	40 - 63 A
Poles	1P + N / 3P + N
Switched Neutral	Yes

## Short Circuit

$I_{\Delta vc}$ Condition Short Circuit Capacity	6000
$I_{nc}$ Condition Short Circuit Capacity	10

## Voltage

Frequency	50 / 60 Hz
Maximum Service Voltage $U_{bmax}$ (2P / 4P)	265 / 455 V AC
Minimum Service Voltage $U_{bmin}$ (2P / 4P)	176 / 287

## Connections

Maximum Cable Size	Rigid / Flexible (Top)	50 mm <sup>2</sup> / 35 mm <sup>2</sup>
	Rigid / Flexible (Bottom)	50 mm <sup>2</sup> / 35 mm <sup>2</sup>

## Application

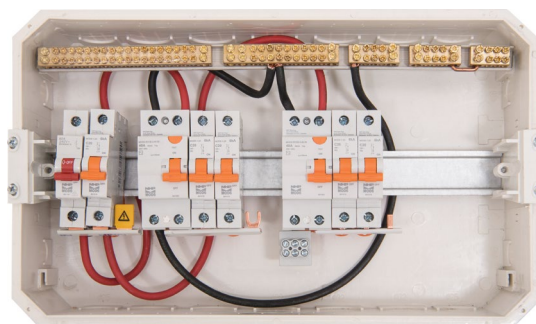

Residential, domestic and light commercial general light and power applications. Suitable for use in MOD6 pole-covers and MOD6 loadcentres.

## Connection

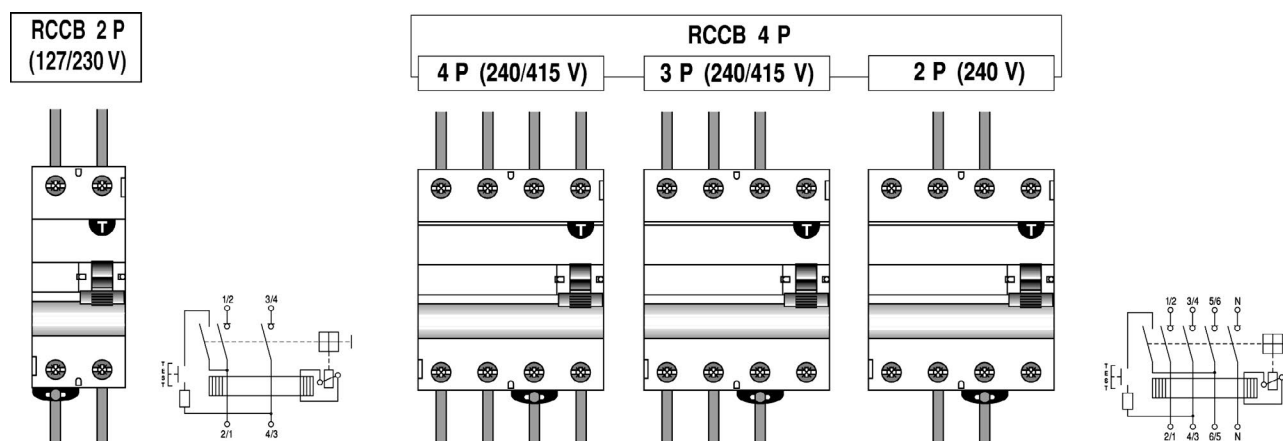

## Dimensions

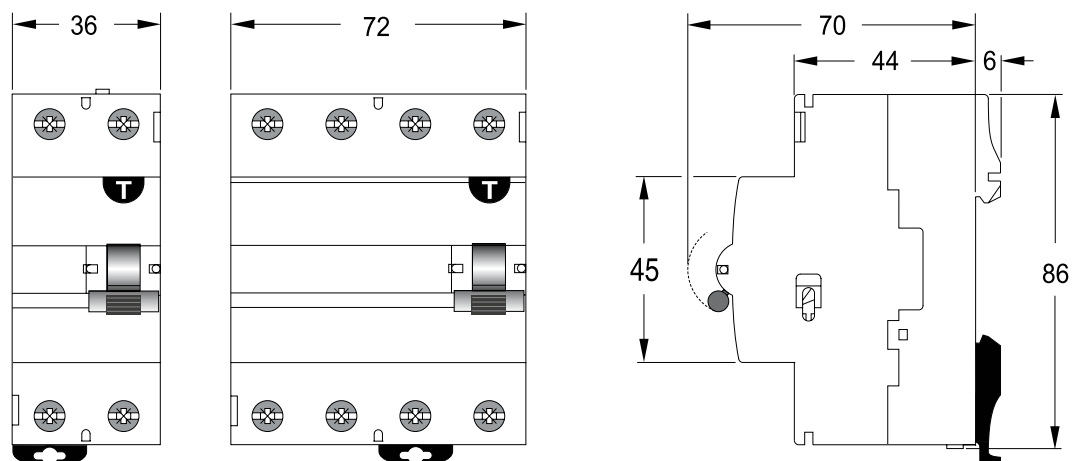



1P + N

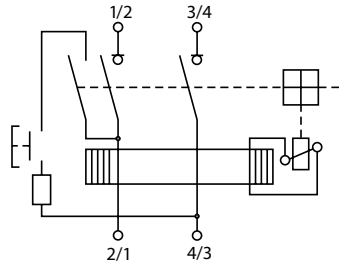

Sensitivity (mA)	Amps (In)	Width (mm)	Type AC	Type A
30	40	36	MOD6RCCB24030	MOD6RCCB24030A
	63	36	MOD6RCCB26330	MOD6RCCB26330A

3P + N

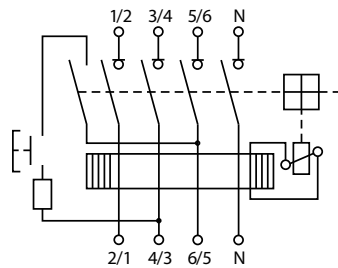

Sensitivity (mA)	Amps (In)	Width (mm)	Type AC	Type A
30	40	72	MOD6RCCB44030	MOD6RCCB44030A
	63	72	MOD6RCCB46330	MOD6RCCB46330A



## Voltage Ratings

Sensitivity $I_{\Delta n}$	30 mA
Tripping Time at $I_{\Delta n}$	< 40 ms
RCD Type	A, AC
Nominal Current Rating at 30 °C	40 - 63 A
Poles	1P + N / 3P + N
Switched Neutral	Yes
Frequency	50 / 60 Hz
Power Supply	Top / Bottom
Maximum Service Voltage $U_{bmax}$	265 / 455 V AC
Minimum Service Voltage $U_{bmin}$	117 / 205 V AC
Isolator Application	IEC 60947-2 Yes
Rated Insulation Voltage	Pollution Degree 2 500 V
Impulse Withstand Test Voltage	6 kV
Insulation Resistance	1000 mOhm
Dielectric Rigidity	2500 V

## Environmental

Vibration Resistance (IEC 77 / 16.3) (in x, y, z direction)	1.5 g	
Endurance	Electrical at $U_n$ , $I_n$	10000 cycles
	Mechanical	20000 cycles
Utilisation Category (IEC 60947-2)		
Protection Degree	Outside	IP20
	Inside	IP40
Self-extinguish Degree (According to UL94)	UL 94 V-2	
Tropicalisation (IEC60068-2 / DIN 40046)	+55 °C / 95 % RH	
Operating Temperature	-5 °C / +55 °C	
Storage Temperature	-25 °C / +70 °C	

## Connection

Rigid Cable Min / Max (Top)	1.5 mm <sup>2</sup> / 50 mm <sup>2</sup>	
Flexible Cable Min / Max (Top)	1.5 mm <sup>2</sup> / 35 mm <sup>2</sup>	
Rigid Cable Min / Max (Bottom)	1.5 mm <sup>2</sup> / 50 mm <sup>2</sup>	
Flexible Cable Min / Max (Bottom)	1.5 mm <sup>2</sup> / 35 mm <sup>2</sup>	
Torque (Top / Bottom)	5 / 5 Nm	
Busbar	Connection Top	Fork / Pin
	Connection Bottom	Fork / Pin

## Physical

Dimensions (H x W x D)	1P + N	86 x 36 x 76 mm
	3P + N	86 x 72 x 76 mm
Weight	0.25 / 0.368 kg	
Package	1 module	

## Short-Circuit Capacity

IEC 61008-1	Rated Making and Breaking Capacity ( $I_m$ )	500	A
	Residual Making and Breaking Capacity ( $I_{\Delta m}$ )	500	A
	Conditional Short-Circuit Capacity ( $I_{nc}$ )	10	kA
	Conditional Residual Short-Circuit Capacity ( $I_{\Delta c}$ )	6	kA

## Power Loss

In (A)	Energy Loss P <sub>w</sub> (W)	Resistance Z (mOhm)
40	3.43	2.15
63	5.15	1.3





## Application

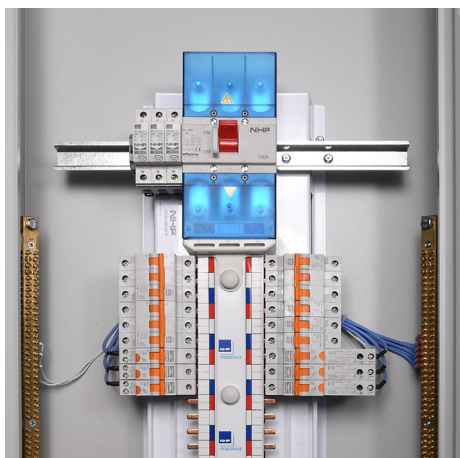

Light commercial general light and power applications. Suitable for use in Concept One Panelboards.

## Connection

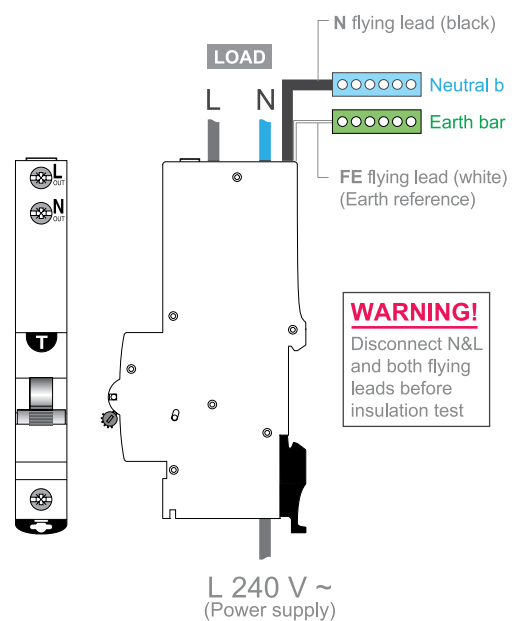

## Dimensions

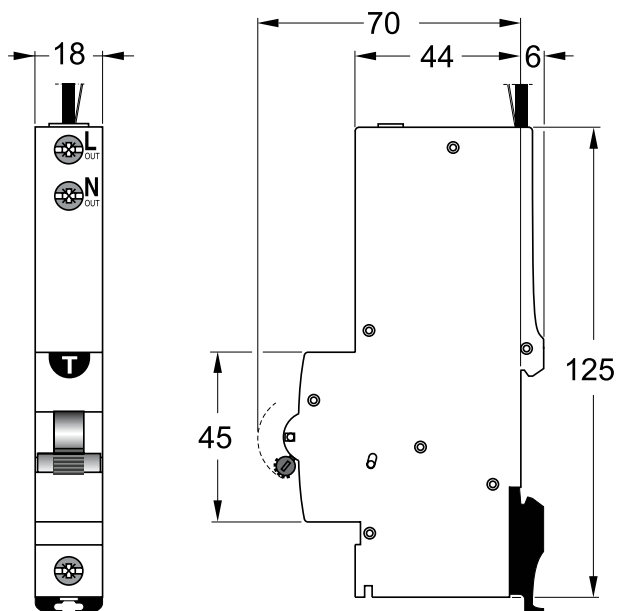

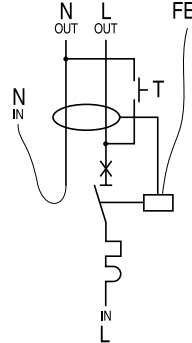

Sensitivity (mA)	Amps (In)	Width (mm)	Type A (Switched Neutral)
30	10	18	MOD6RCBO11030AL
	16	18	MOD6RCBO11630AL
	20	18	MOD6RCBO12030AL
	25	18	MOD6RCBO12530AL
	32	18	MOD6RCBO13230AL



## Voltage Ratings

Sensitivity $I_{\Delta n}$	30 mA	
Tripping Time at $I_{\Delta n}$	< 40 ms	
RCD Type	A	
Nominal current rating at 30 °C	10 - 32 A	
Poles	1P + N	
Switched Neutral	No	
Frequency	50 / 60 Hz	
Power Supply	Bottom	
Maximum Service Voltage $U_{bmax}$	255 V AC	
Minimum Service Voltage $U_{bmin}$	195 V AC	
Isolator Application	IEC 60947-2 Yes	
Rated Insulation Voltage	Pollution Degree 2	500 V
	Pollution Degree 3	440 V
Impulse Withstand Test Voltage	6 kV	
Insulation Resistance	1000 mOhm	
Dielectric Rigidity	2500 V	

## Environmental

Vibration Resistance (IEC 77 / 16.3) (in x, y, z direction)	2 g	
Endurance	Electrical at $U_n$ , $I_n$	10000 cycles
	Mechanical	20000 cycles
Utilisation Category (IEC 60947-2)	-	
Protection Degree	Outside	IP20
	Inside	IP40
Self-extinguish Degree (According to UL94)	UL 94 V-2	
Tropicalisation (IEC60068-2 / DIN 40046)	+55 °C / 95 % RH	
Operating Temperature	-5 °C / +55 °C	
Storage Temperature	-25 °C / +70 °C	

## Connection

Rigid Cable Min / Max (Top)	1 mm <sup>2</sup> / 25 mm <sup>2</sup>	
Flexible Cable Min / Max (Top)	1 mm <sup>2</sup> / 16 mm <sup>2</sup>	
Rigid Cable Min / Max (Bottom)	1 mm <sup>2</sup> / 35 mm <sup>2</sup>	
Flexible Cable Min / Max (Bottom)	1 mm <sup>2</sup> / 25 mm <sup>2</sup>	
Torque (Top / Bottom)	3 / 4.5 Nm	
Busbar	Connection Top	
	Connection Bottom	Fork / Pin

## Physical

Dimensions (H x W x D)	1P + N	125 x 18 x 76 mm
Weight		0.235 kg
Package		1 module

## Short-Circuit Capacity

IEC 61009-1	Rated Making and Breaking Capacity ( $I_m$ )	500	A
	Residual Making and Breaking Capacity ( $I_{\Delta m}$ )	6000	A
	Conditional Short-Circuit Capacity ( $I_{nc}$ )	6	kA
	Conditional Residual Short-Circuit Capacity ( $I_{\Delta c}$ )	6	kA
	Rated Short-Circuit Capacity ( $I_{cn}$ )	6	kA



### C-Curve Characteristics

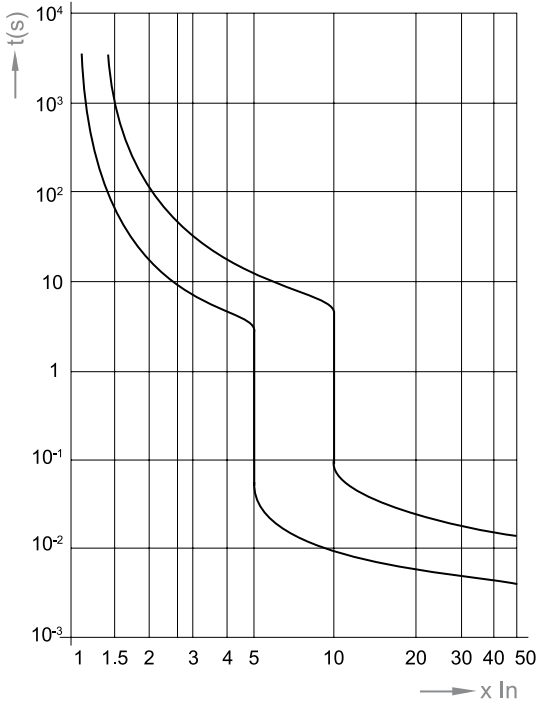

### Ambient Temperature Influence at 10 A

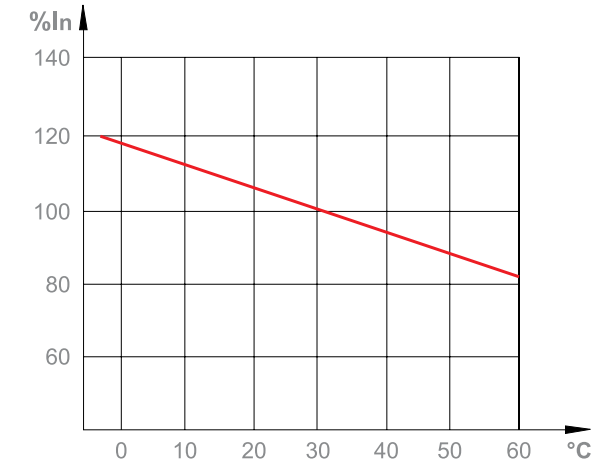

### Let-through Energy I²t (A²s) C-Curve

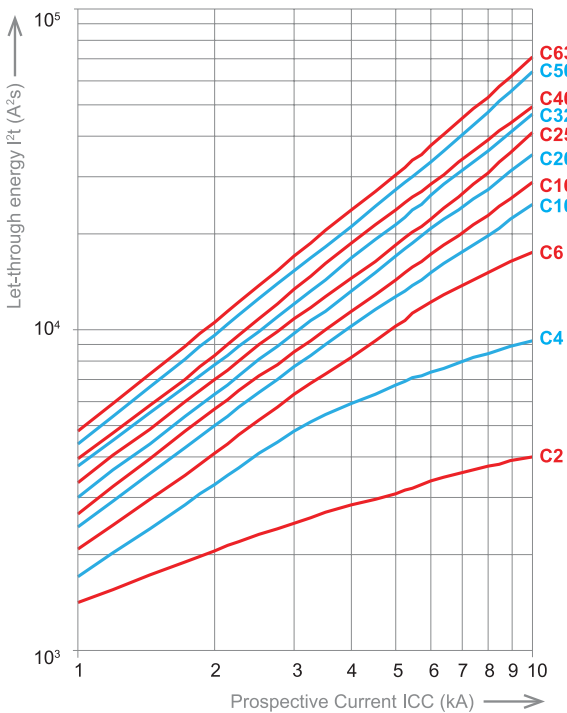

### Ambient Temperature Influence at 16-32 A

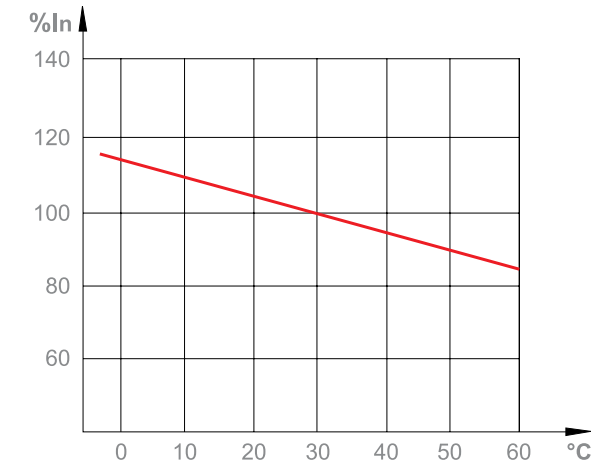

### Power Loss

In (A)	Energy Loss Pw (W)	Resistance Z (mOhm)	Voltage Drop (V)
10	1.56	15.6	0.16
16	2.566	10.1	0.162
20	2.76	6.9	0.138
25	3.188	5.1	0.128
32	3.188	3	0.096
40	4	2.5	0.1

# MOD6 Compact RCBO 6kA (RCBS) Loadcentre / Panelboard Model

(with Pigtail)



- ✓ Complies with AS/NZS 61009 (RCBOs)
- ✓ MOD6 RCBOs feature 6 kA short circuit rating
- ✓ Compact single screw RCBO features a neutral pigtail saving cable and installation time
- ✓ Type A RCD with switched neutral
- ✓ 30 mA sensitivity general personnel protection applications
- ✓ 10 mA sensitivity option for higher risk applications
- ✓ C trip curve for general light and power applications
- ✓ Fast connection pin / fork busbar comb or busbar chassis
- ✓ Suits pole-covers, loadcentres and Concept One Panelboards
- ✓ Approval No. NSW24576 or RCM
- ✓ Energy Safe Victoria (ESV) compliant for residential applications
- ✓ 10 mA units compliant with Type 1 requirements



## General

Tripping Characteristics	C
Sensitivity $I\Delta n$	10, 30 mA
RCD Type	A
Nominal Current Rating at 30 °C	6 - 32 A
Poles	1P + N
Switched Neutral	Yes

## Short Circuit

$I_{cn}$ 230 1P	6000
$I\Delta m$	6

## Voltage

Frequency	50 / 60 Hz
Maximum Service Voltage $U_{bmax}$	255 V AC
Minimum Service Voltage $U_{bmin}$	195

## Connections

Maximum Cable Size	Rigid / Flexible (Top)	25 mm <sup>2</sup> / 16 mm <sup>2</sup>
	Rigid / Flexible (Bottom)	35 mm <sup>2</sup> / 25 mm <sup>2</sup>



## Application

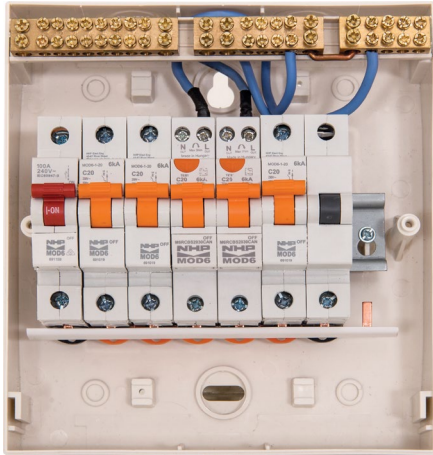

Light commercial general light and power applications. Suitable for use in loadcentres and Concept One Panelboards.

## Connection

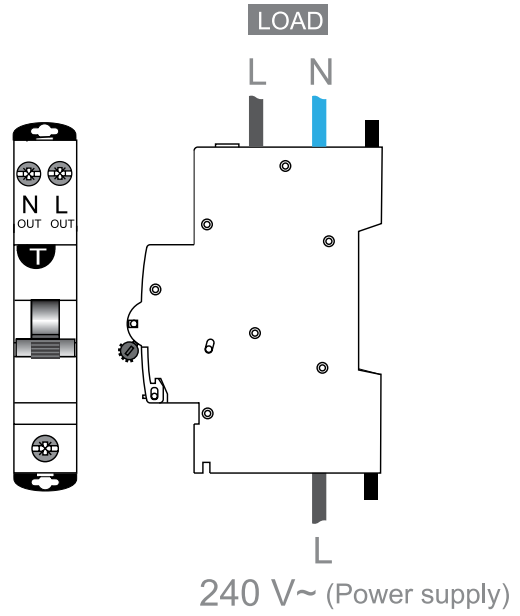

## Dimensions

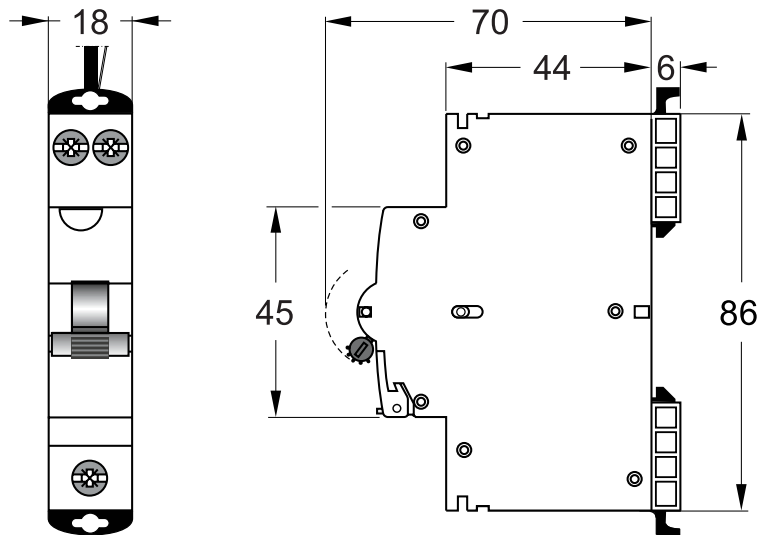

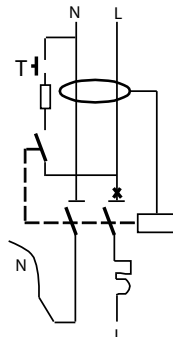

**Sensitivity (mA)      Amps (In)      Width (mm)      Type A (Switched Neutral)**

10	6	18	M6RCBS0610CAN
	10	18	M6RCBS1010CAN
	16	18	M6RCBS1610CAN
	20	18	M6RCBS2010CAN
	25	18	M6RCBS2510CAN
	32	18	M6RCBS3210CAN
30	6	18	M6RCBS0630CAN
	10	18	M6RCBS1030CAN
	16	18	M6RCBS1630CAN
	20	18	M6RCBS2030CAN
	25	18	M6RCBS2530CAN
	32	18	M6RCBS3230CAN

## Voltage Ratings

Sensitivity $I_{\Delta n}$	10, 30 mA	
Tripping Time at $I_{\Delta n}$	< 40 ms	
RCD Type	A	
Nominal current rating at 30 °C	6 - 32 A	
Poles	1P + N	
Switched Neutral	Yes	
Frequency	50 / 60 Hz	
Power Supply	Top / Bottom	
Maximum Service Voltage $U_{bmax}$	255 V AC	
Minimum Service Voltage $U_{bmin}$	195 V AC	
Isolator Application	IEC 60947-2	Yes
Rated Insulation Voltage	Pollution Degree 2	500 V
	Pollution Degree 3	440 V
Impulse Withstand Test Voltage	6 kV	
Insulation Resistance	1000 mOhm	
Dielectric Rigidity	2500 V	

## Environmental

Vibration Resistance (IEC 77 / 16.3) (in x, y, z direction)	1.5 g	
Endurance	Electrical at $U_n, I_n$	10000 cycles
	Mechanical	20000 cycles
Utilisation Category (IEC 60947-2)	-	
Protection Degree	Outside	IP20
	Inside	IP40
Self-extinguish Degree (According to UL94)	UL 94 V-2	
Tropicalisation (IEC60068-2 / DIN 40046)	+55 °C / 95 % RH	
Operating Temperature	-5 °C / +55 °C	
Storage Temperature	-25 °C / +70 °C	

## Connection

Rigid Cable Min / Max (Top)	1 mm <sup>2</sup> / 25 mm <sup>2</sup>	
Flexible Cable Min / Max (Top)	1 mm <sup>2</sup> / 16 mm <sup>2</sup>	
Rigid Cable Min / Max (Bottom)	1.5 mm <sup>2</sup> / 35 mm <sup>2</sup>	
Flexible Cable Min / Max (Bottom)	1.5 mm <sup>2</sup> / 25 mm <sup>2</sup>	
Torque (Top / Bottom)	3 / 4.5 Nm	
Busbar	Connection Top	Fork / Pin
	Connection Bottom	Fork / Pin

## Physical

Dimensions (H x W x D)	1P + N	86 x 18 x 76 mm
Weight	0.215 kg	
Package	1 module	

## Short-Circuit Capacity

IEC 61009-1	Rated Making and Breaking Capacity ( $I_m$ )	500	A
	Residual Making and Breaking Capacity ( $I_{\Delta m}$ )	6000	A
	Conditional Short-Circuit Capacity ( $I_{nc}$ )	6	kA
	Conditional Residual Short-Circuit Capacity ( $I_{\Delta c}$ )	6	kA
	Rated Short-Circuit Capacity ( $I_{cn}$ )	6	kA



## C-Curve Characteristics

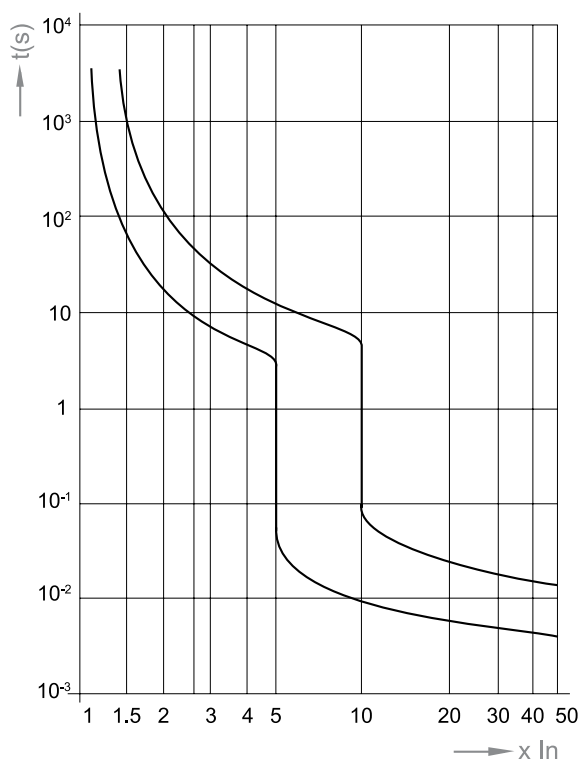

## Let-through Energy $I^2t$ (A<sup>2</sup>s) C-Curve

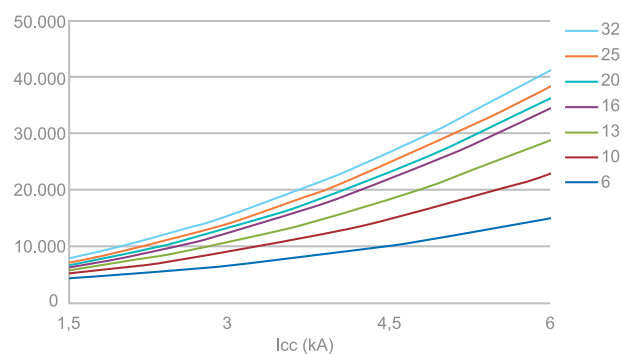

## Limited Peak Current (kA) at 230 / 400V C-Curve

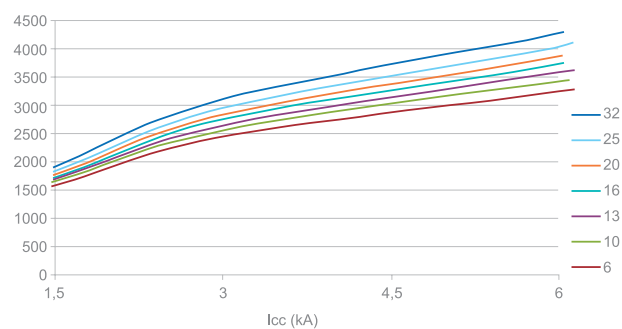

## Power Loss

In (A)	Power Loss (W)		
	Neutral Pole	Phase Pole	IEC60898-1 Limit
6	0.1	1.7	3
10	0.2	1.8	3
16	0.5	2.0	3.5
20	0.7	2.3	4.5
25	1.1	2.6	4.5
32	1.7	3.1	6.0

# MOD6 Compact RCBO 6kA (RCBD) Loadcentre Model



- ✓ Complies with AS/NZS 61009 (RCBOs)
- ✓ MOD6 RCBOs feature 6 kA short circuit rating
- ✓ Compact double screw RCBO
- ✓ Type A RCD with switched neutral
- ✓ 30 mA sensitivity general personnel protection applications
- ✓ 10 mA sensitivity option for higher risk applications
- ✓ C trip curve for general light and power applications
- ✓ Fast connection special pin busbar comb
- ✓ Suits pole-covers and loadcentres
- ✓ Approval No. NSW24576 or RCM
- ✓ Energy Safe Victoria (ESV) compliant for residential applications
- ✓ 10 mA units compliant with Type 1 requirements



## General

Tripping Characteristics	C
Sensitivity $I\Delta n$	10, 30 mA
RCD Type	A
Nominal Current Rating at 30 °C	6 - 32 A
Poles	1P + N
Switched Neutral	Yes

## Short Circuit

$I_{cn} 230 1P$	6000
$I\Delta m$	6

## Voltage

Frequency	50 / 60 Hz
Maximum Service Voltage $U_{bmax}$	255 V AC
Minimum Service Voltage $U_{bmin}$	195

## Connections

Maximum Cable Size	Rigid / Flexible (Top)	25 mm <sup>2</sup> / 16 mm <sup>2</sup>
	Rigid / Flexible (Bottom)	25 mm <sup>2</sup> / 16 mm <sup>2</sup>

## Application

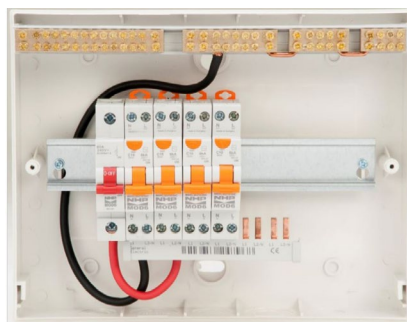

Residential, domestic and light commercial general light and power applications including 10 mA unit for home care medical equipment. Suitable for use in MOD6 pole-covers and MOD6 loadcentres.

## Dimensions

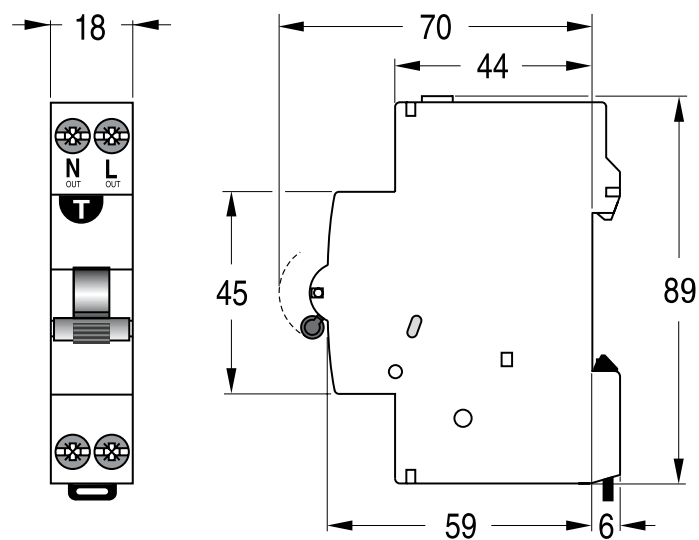

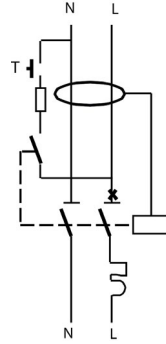

Sensitivity (mA)	Amps (In)	Width (mm)	Type A (Switched Neutral)
10	6	18	M6RCBD0610CAN
	10	18	M6RCBD1010CAN
	16	18	M6RCBD1610CAN
	20	18	M6RCBD2010CAN
	25	18	M6RCBD2510CAN
	32	18	M6RCBD3210CAN
30	6	18	M6RCBD0630CAN
	10	18	M6RCBD1030CAN
	16	18	M6RCBD1630CAN
	20	18	M6RCBD2030CAN
	25	18	M6RCBD2530CAN
	32	18	M6RCBD3230CAN

## Voltage Ratings

Sensitivity $I_{\Delta n}$	10, 30 mA	
Tripping Time at $I_{\Delta n}$	< 40 ms	
RCD Type	A	
Nominal current rating at 30 °C	6 - 32 A	
Poles	1P + N	
Switched Neutral	Yes	
Frequency	50 / 60 Hz	
Power Supply	Top / Bottom	
Maximum Service Voltage $U_{bmax}$	255 V AC	
Minimum Service Voltage $U_{bmin}$	195 V AC	
Isolator Application	IEC 60947-2	Yes
Rated Insulation Voltage	Pollution Degree 2	500 V
	Pollution Degree 3	440 V
Impulse Withstand Test Voltage	6 kV	
Insulation Resistance	1000 mOhm	
Dielectric Rigidity	2500 V	

## Environmental

Vibration Resistance (IEC 77 / 16.3) (in x, y, z direction)	2 g	
Endurance	Electrical at $U_n$ , $I_n$	10000 cycles
	Mechanical	20000 cycles
Utilisation Category (IEC 60947-2)		
Protection Degree	Outside	IP20
	Inside	IP40
Self-extinguish Degree (According to UL94)	UL 94 V-2	
Tropicalisation (IEC60068-2 / DIN 40046)	+55 °C / 95 % RH	
Operating Temperature	-5 °C / +55 °C	
Storage Temperature	-25 °C / +70 °C	

## Connection

Rigid Cable Min / Max (Top)	1 mm <sup>2</sup> / 25 mm <sup>2</sup>	
Flexible Cable Min / Max (Top)	1.5 mm <sup>2</sup> / 16 mm <sup>2</sup>	
Rigid Cable Min / Max (Bottom)	1 mm <sup>2</sup> / 25 mm <sup>2</sup>	
Flexible Cable Min / Max (Bottom)	1.5 mm <sup>2</sup> / 16 mm <sup>2</sup>	
Torque (Top / Bottom)	3 / 3 Nm	
Busbar	Connection Top	Pin
	Connection Bottom	Pin

## Physical

Dimensions (H x W x D)	1P + N	86 x 18 x 76 mm
Weight	0.125 kg	
Package	1 module	

## Short-Circuit Capacity

IEC 61009-1	Rated Making and Breaking Capacity ( $I_m$ )	500	A
	Residual Making and Breaking Capacity ( $I_{\Delta m}$ )	6000	A
	Conditional Short-Circuit Capacity ( $I_{nc}$ )	6	kA
	Conditional Residual Short-Circuit Capacity ( $I_{\Delta c}$ )	6	kA
	Rated Short-Circuit Capacity ( $I_{cn}$ )	6	kA



### C-Curve Characteristics

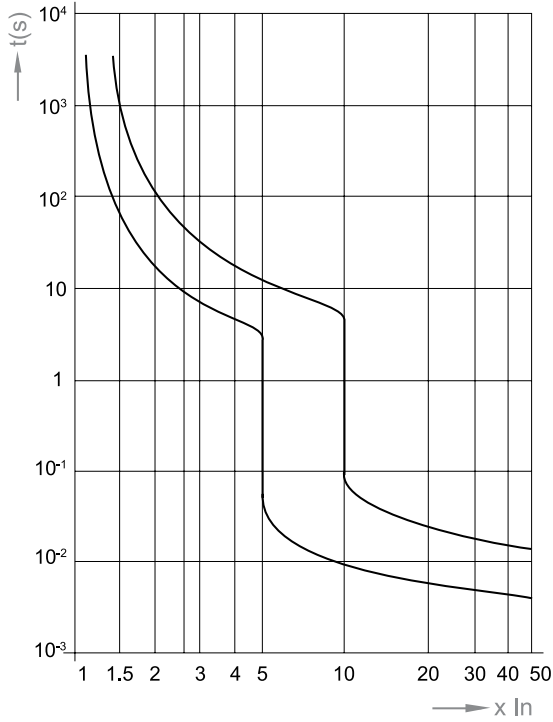

### Limited Peak Current (kA) at 230 / 400V C-Curve

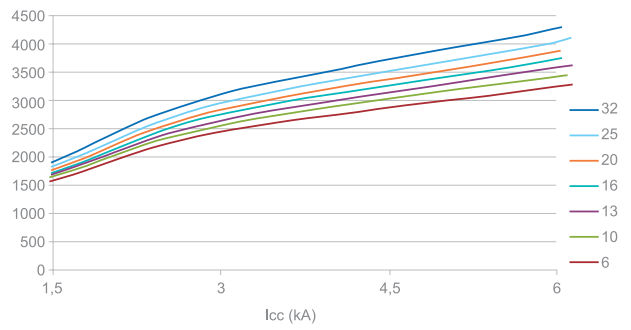

### Power Loss

In (A)	Power Loss (W)		
	Neutral Pole	Phase Pole	IEC60898-1 Limit
6	0.1	1.7	3
10	0.2	1.8	3
16	0.5	2.0	3.5
20	0.7	2.3	4.5
25	1.1	2.6	4.5
32	1.7	3.1	6.0

### Let-through Energy I²t (A²s) C-Curve

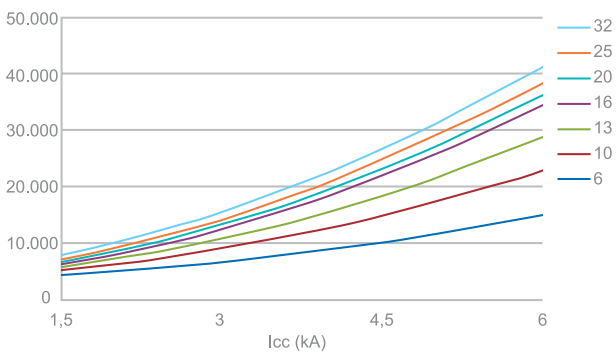

# MOD6 RCBO2 6kA 2 Pole Width



- ✓ Complies with AS/NZS 61009 (RCBOs)
- ✓ MOD6 RCBOs feature 6 kA short circuit rating
- ✓ Type AC or Type A RCD with switched neutral
- ✓ 30 mA sensitivity general personnel protection applications
- ✓ 10 mA sensitivity option for higher risk applications
- ✓ C trip curve for general light and power applications
- ✓ Fast connection pin / fork busbar comb
- ✓ Suits pole-covers and loadcentres
- ✓ Approval No. NSW17482 or RCM
- ✓ Energy Safe Victoria (ESV) compliant for residential applications
- ✓ 10 mA units compliant with Type 1 requirements



## General

Tripping Characteristics	C
Sensitivity $I_{\Delta n}$	10, 30 mA
RCD Type	A, AC
Nominal Current Rating at 30 °C	6 - 40 A
Poles	1P + N
Switched Neutral	Yes

## Short Circuit

$I_{cn}$ 230 1P	6000
$I_{\Delta m}$	6

## Voltage

Frequency	50 / 60 Hz
Maximum Service Voltage $U_{bmax}$	255 V AC
Minimum Service Voltage $U_{bmin}$	176

## Connections

Maximum Cable Size	Rigid / Flexible (Top)	25 mm <sup>2</sup> / 16 mm <sup>2</sup>
	Rigid / Flexible (Bottom)	35 mm <sup>2</sup> / 25 mm <sup>2</sup>



## Application

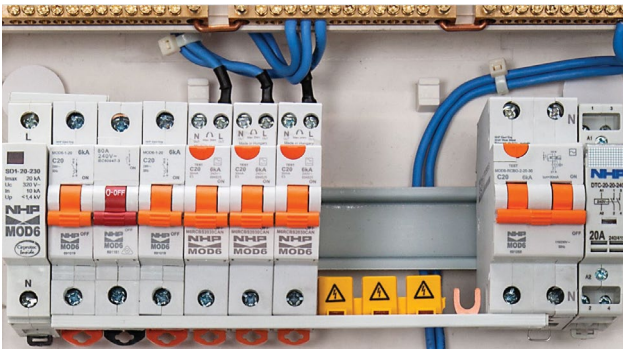

Residential, domestic and light commercial general light and power applications including 10 mA unit for home care medical equipment. Suitable for use in MOD6 pole-covers and MOD6 loadcentres.

## Connection

Neutral Active

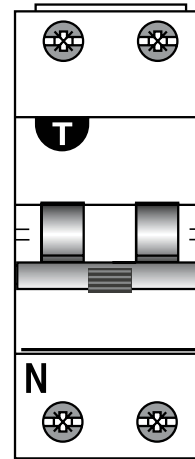

Neutral Active

## Dimensions

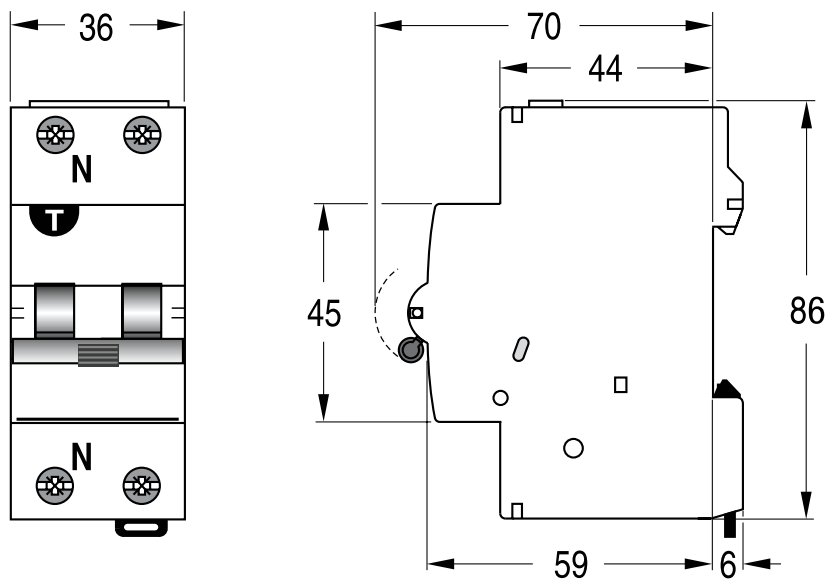



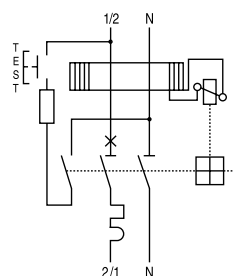

Sensitivity (mA)	Amps (In)	Width (mm)	Type A (Switched Neutral)	Type AC
<b>10 mA</b>	6	36	MOD6RCBO20610A	-
	10	36	MOD6RCBO21010A	-
	16	36	MOD6RCBO21610A	-
	20	36	MOD6RCBO22010A	-
<b>30 mA</b>	10	36	MOD6RCBO21030A	MOD6RCBO21030
	16	36	MOD6RCBO21630A	MOD6RCBO21630
	20	36	MOD6RCBO22030A	MOD6RCBO22030
	25	36	MOD6RCBO22530A	MOD6RCBO22530
	32	36	MOD6RCBO23230A	MOD6RCBO23230
	40	36	MOD6RCBO24030A	-

## Voltage Ratings

Sensitivity $I_{\Delta n}$	10, 30 mA	
Tripping Time at $I_{\Delta n}$	< 40 ms	
RCD Type	A, AC	
Nominal current rating at 30 °C	6 - 40A	
Poles	1P + N	
Switched Neutral	Yes	
Frequency	50 / 60 Hz	
Power Supply	Top / Bottom	
Maximum Service Voltage $U_{bmax}$	255 V AC	
Minimum Service Voltage $U_{bmin}$	176 V AC	
Isolator Application	IEC 60947-2	Yes
Rated Insulation Voltage	Pollution Degree 2	500 V
	Pollution Degree 3	440 V
Impulse Withstand Test Voltage	6 kV	
Insulation Resistance	1000 mOhm	
Dielectric Rigidity	2500 V	

## Environmental

Vibration Resistance (IEC 77 / 16.3) (in x, y, z direction)	1.5 g	
Endurance	Electrical at $U_n, I_n$	10000 cycles
	Mechanical	20000 cycles
Utilisation Category (IEC 60947-2)	-	
Protection Degree	Outside	IP20
	Inside	IP40
Self-extinguish Degree (According to UL94)	UL 94 V-2	
Tropicalisation (IEC60068-2 / DIN 40046)	+55 °C / 95 % RH	
Operating Temperature	-5 °C / +55 °C	
Storage Temperature	-25 °C / +70 °C	

## Connection

Rigid Cable Min / Max (Top)	1 mm <sup>2</sup> / 25 mm <sup>2</sup>	
Flexible Cable Min / Max (Top)	1 mm <sup>2</sup> / 16 mm <sup>2</sup>	
Rigid Cable Min / Max (Bottom)	1 mm <sup>2</sup> / 35 mm <sup>2</sup>	
Flexible Cable Min / Max (Bottom)	1 mm <sup>2</sup> / 25 mm <sup>2</sup>	
Torque (Top / Bottom)	3 / 4 Nm	
Busbar	Connection Top	Fork / Pin
	Connection Bottom	Fork / Pin

## Physical

Dimensions (H x W x D)	1P + N	86 x 36 x 76 mm
Weight	0.25 kg	
Package	1 module	

## Short-Circuit Capacity

IEC 61009-1	Rated Making and Breaking Capacity ( $I_m$ )	320	A
	Residual Making and Breaking Capacity ( $I_{\Delta m}$ )	6000	A
	Conditional Short-Circuit Capacity ( $I_{nc}$ )	6	kA
	Conditional Residual Short-Circuit Capacity ( $I_{\Delta c}$ )	6	kA
	Rated Short-Circuit Capacity ( $I_{cn}$ )	6	kA



### C-Curve Characteristics

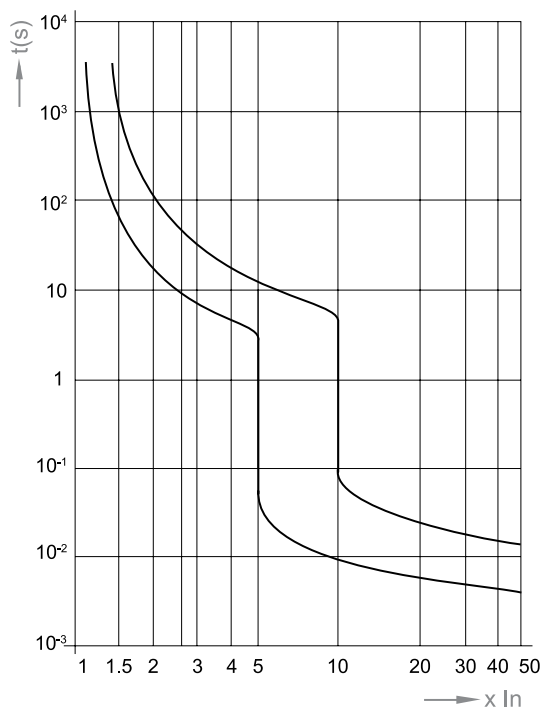

### Ambient Temperature Influence at 6 A

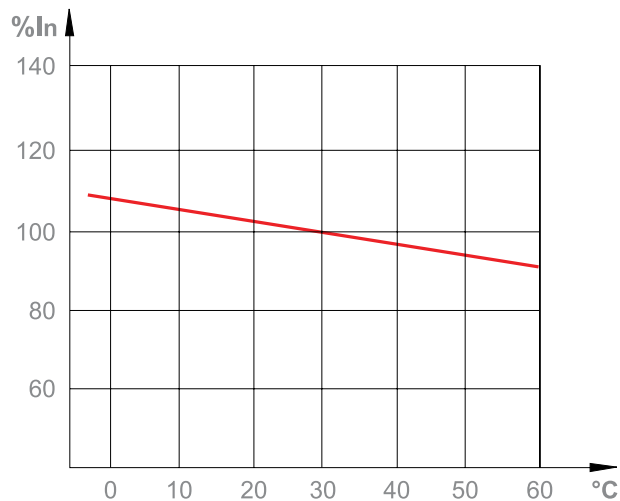

### Let-through Energy $I^2t$ (A<sup>2</sup>s)

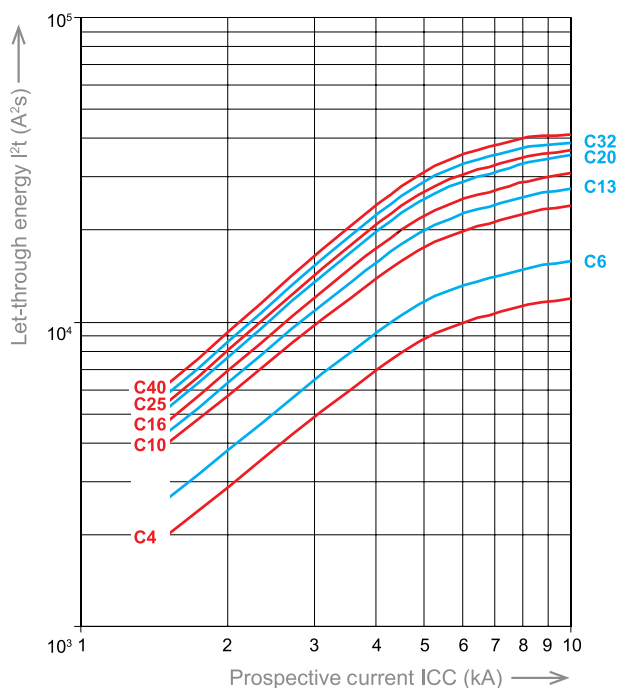

### Ambient Temperature Influence at 10 A

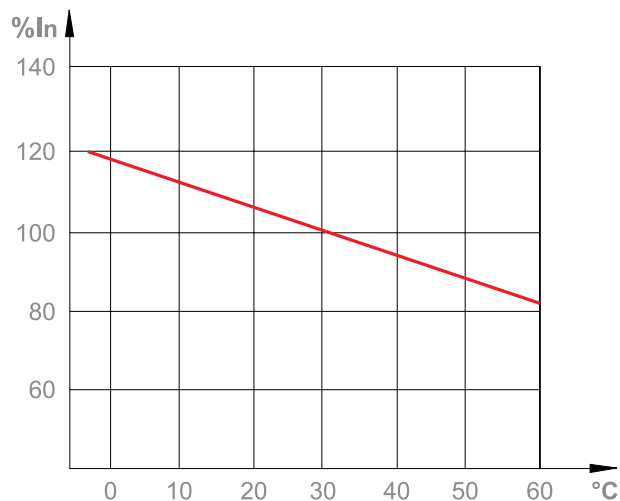

MCBs and RCBOs



## Ambient Temperature Influence at 16-32 A

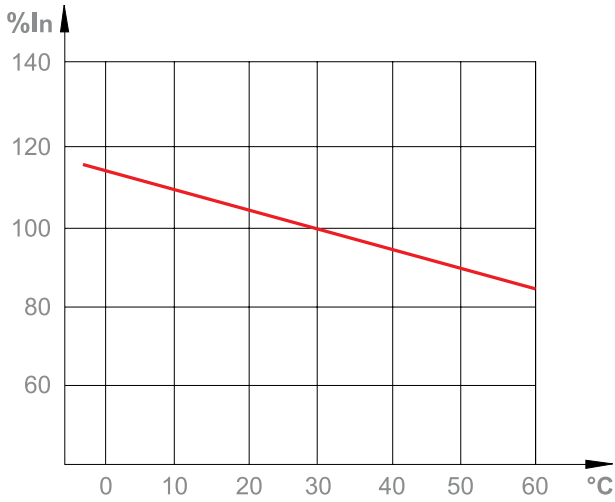

## Power Loss

In (A)	Energy Loss Pw (W)	Resistance Z (mOhm)
6	1.91	53
10	1.63	16.3
16	2.51	9.8
20	2.84	7.1
25	3.5	5.6
32	4.81	4.7
40	5.76	3.6

## MOD6 Main Switch

### 1P, 2P and 3P Main Switches

Main Switch to isolate incoming supply or outgoing loads up to 100 A.



Item Description	Catalogue No.
MOD6 Main Switch, DIN Rail, 1P, 80 A	MOD6MS180
MOD6 Main Switch, DIN Rail, 1P, 100 A	MOD6MS1100



Item Description	Catalogue No.
MOD6 Main Switch, DIN Rail, 2P, 100 A	MOD6MS2100



Item Description	Catalogue No.
MOD6 Main Switch, DIN Rail, 3P, 100 A	MOD6MS3100

## Busbar Comb

### IBC, ICL and IBD Busbar Comb

Suitable for linking MOD6 Main Switches, MCBs and RCBOs in MOD6 pole-covers and MOD6 loadcentres. ICL and IBC are suited for regular 18 mm pitch terminals on MSW, MCBs and RCBOs. IBD is suited for 9 mm pitch terminals on 2-in-1 MCBs and M6RCBD RCBOs. Fork Type comb goes under the terminal screw head and Pin Type into the devices main terminal.

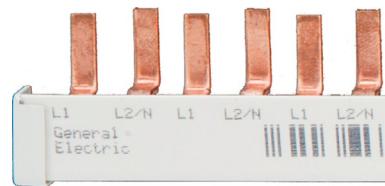
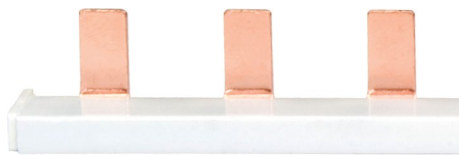

Item Description	Catalogue No.
Busbar Comb, 12 way, 100 A, 1P, Pin type with end caps	IBC112P
Busbar Comb, 15 way, 100 A, 1P, Pin type with end caps	IBC115P
Busbar Comb, 18 way, 100 A, 1P, Pin type with end caps	IBC118P

Item Description	Catalogue No.
Busbar Comb, 18 way, 1P+N, 80 A / 100 A, suits M6RCBD and DTCBD	IBD218P
Busbar Comb, 55 way, 1P+N, 80 A / 100 A, suits M6RCBD and DTCBD	IBD255P

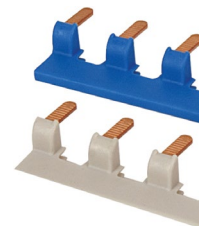
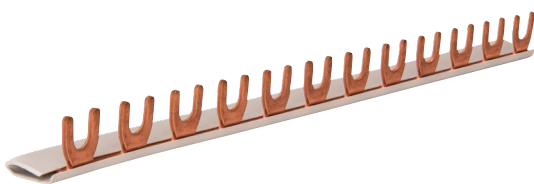

Item Description	Catalogue No.
Busbar Comb, 4 way, 1P, 80 A / 130 A, Fork type	ICL41F
Busbar Comb, 12 way, 1P, 90 A / 150 A, Fork type	ICL121F
Busbar Comb, 18 way, 1P, 80 A / 130 A, Fork type	ICL181F
Busbar Comb, 56 way, 1P, 110 A / 130 A, Fork type	ICL561F
Busbar Comb, 57 way, 3P, 110 A / 130 A, Fork type	ICL573F

Item Description	Catalogue No.
Busbar Comb Kit (blue and grey), 13 way, 63 A, 1P+N, suits M6RCBD	IBD213P



## Busbar Comb End Caps

### IBC and IBD Busbar End Caps

End caps to cover the end of cut busbar comb.



Item Description	Catalogue No.
Buscomb End Cap to suit 1P IBC	IBCEC1
Buscomb End Cap to suit 2P IBD	IBDEC2
Buscomb End Cap to suit 4P IBD	IBDEC4

## General Accessories

### Pole Filler, Lock Dogs and Terminals

Lock Dog to securely lock off devices. Pole filler to cover unused spaces in loadcentres and Panelboards. Terminal pins to allow connection of larger cables or multiple cables to a terminal.



Item Description	Catalogue No.
DIN Lock Dog, Non-Captive suits hasp up to 8.0 mm.	DTLD



Item Description	Catalogue No.
DIN Pole Filler (1 strip of 4 poles, 8 x 9 mm segments)	DTPF



Item Description	Catalogue No.
Terminal 3 x 16 mm neutral link to suit RCCB	DTTAX16PN3



Item Description	Catalogue No.
Terminal Pin 25 mm to suit DIN MCBs	DTTTL25PN2



# DIN-T6



- ✓ High speed and rapid arc quenching technology ensuring the highest level of protection is provided
- ✓ DIN rail mounting
- ✓ Free tripping mechanism even if toggle is locked ON or OFF
- ✓ Complies with AS/NZS 60898 and AS/NZS 60947-2 (as applicable)
- ✓ DIN-T6 MCBs feature 6 kA short circuit rating
- ✓ C curve for general light, power and motor starting applications
- ✓ D trip curve for high inrush, motor starting and transformer applications
- ✓ Pad lockable and sealable toggle restricts unauthorized action
- ✓ Large capacity terminals
- ✓ Fast connection pin / fork busbar comb or NC or GB busbar chassis
- ✓ Suits pole-covers, loadcentres and the Concept range of Panelboards
- ✓ Approval No. N17481 or RCM



## General

Tripping Characteristics	C, D
Nominal Current Rating At 30 °C	2 - 63 A
Poles	1P / 2P / 3P
Neutral Pole Protected	Yes

## Short Circuit

Icn 230 / 400 V 1P / 2P / 3P	6 / 6 / 6 kA
------------------------------	--------------

## Voltage

Nominal Voltage Un	AC	1P	240, 415 V AC
		3P / 4P	415 V AC
	DC	1P	48 V DC
		2P (In Series)	110 V DC

Frequency	50 / 60 Hz
Maximum Service Voltage U <sub>max</sub>	250 / 440 V AC 53 / 120 V DC
Minimum Service Voltage U <sub>min</sub>	12 V AC

## Connections

Maximum Cable Size	Rigid / Flexible (Top)	35 mm <sup>2</sup> / 25 mm <sup>2</sup>
	Rigid / Flexible (Bottom)	35 mm <sup>2</sup> / 25 mm <sup>2</sup>

## Application

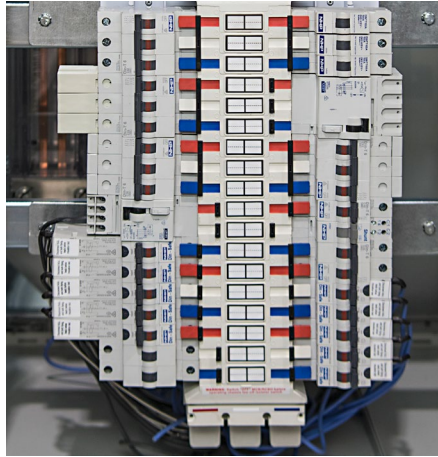

Residential, commercial and industrial general light and power applications. Suitable for use in pole-covers, loadcentres utilising fork or pin busbar comb and the Concept range of Panelboards using busbar chassis.

## Dimensions

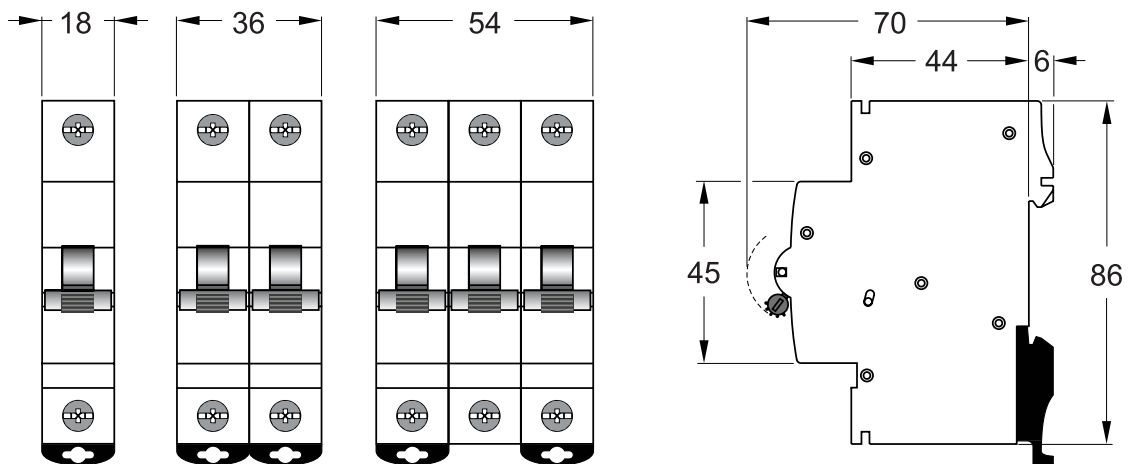

1 Pole

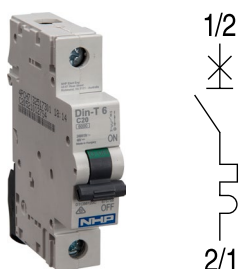

2 Pole

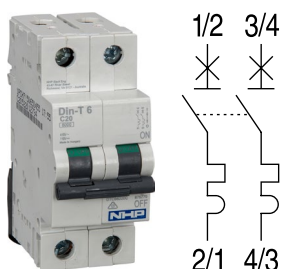

3 Pole

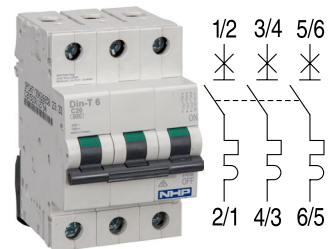

Width                      18 mm    36 mm    54 mm

Amps (In)	C-Curve (5-10 In)	D-Curve (10-20 In)	C-Curve (5-10 In)	D-Curve (10-20 In)	C-Curve (5-10 In)	D-Curve (10-20 In)
2	DTCB6102C	DTCB6102D	DTCB6202C	DTCB6202D	DTCB6302C	DTCB6302D
4	DTCB6104C	DTCB6104D	DTCB6204C	DTCB6204D	DTCB6304C	DTCB6304D
6	DTCB6106C	DTCB6106D	DTCB6206C	DTCB6206D	DTCB6306C	DTCB6306D
10	DTCB6110C	DTCB6110D	DTCB6210C	DTCB6210D	DTCB6310C	DTCB6310D
13	DTCB6113C	DTCB6113D	DTCB6213C	DTCB6213D	DTCB6313C	DTCB6313D
16	DTCB6116C	DTCB6116D	DTCB6216C	DTCB6216D	DTCB6316C	DTCB6316D
20	DTCB6120C	DTCB6120D	DTCB6220C	DTCB6220D	DTCB6320C	DTCB6320D
25	DTCB6125C	DTCB6125D	DTCB6225C	DTCB6225D	DTCB6325C	DTCB6325D
32	DTCB6132C	DTCB6132D	DTCB6232C	DTCB6232D	DTCB6332C	DTCB6332D
40	DTCB6140C	DTCB6140D	DTCB6240C	DTCB6240D	DTCB6340C	DTCB6340D
50	DTCB6150C	DTCB6150D	DTCB6250C	DTCB6250D	DTCB6350C	DTCB6350D
63	DTCB6163C	DTCB6163D	DTCB6263C	DTCB6263D	DTCB6363C	DTCB6363D

## Voltage Ratings

Nominal Voltage $U_n$	AC	1P	240, 415 V AC
		3P / 4P	415 V AC
	DC	1P	48 V DC
		2P (In Series)	110 V DC
Frequency	50 / 60 Hz		
	DC: 1.4 x mag. trip		
	400 Hz: 1.5 x mag. trip		
Maximum Service Voltage $U_{bmax}$		250 / 440 V AC 53 / 120 V DC	
Minimum Service Voltage $U_{bmin}$		12	
Selectivity Class (IEC 60898)		A	
Isolator Application	IEC 60947-2	Yes	
	Rated Insulation Voltage	Pollution Degree 2	500 V
		Pollution Degree 3	440 V
Impulse Withstand Test Voltage		6 kV	
Insulation Resistance		10000 mOhm	
Dielectric Rigidity		2.5 kV	

## Environmental

Vibration Resistance (IEC 77 / 16.3) (in x, y, z direction)		3 g
Endurance	Electrical at $U_n, I_n$	10000 cycles
	Mechanical	20000 cycles
Utilisation Category (IEC 60947-2)		A
Protection Degree	Outside	IP20
	Inside	IP40
Self-extinguish Degree (According to UL94)		UL 94 V-2
Tropicalisation (IEC60068-2 / DIN 40046)		+55 °C / 95 % RH
Operating Temperature		-25 °C / +55 °C
Storage Temperature		-55 °C / +55 °C

## Connection

Rigid Cable Min / Max (Top)		1 mm <sup>2</sup> / 35 mm <sup>2</sup>
Flexible Cable Min / Max (Top)		0.75 mm <sup>2</sup> / 25 mm <sup>2</sup>
Rigid Cable Min / Max (Bottom)		1 mm <sup>2</sup> / 35 mm <sup>2</sup>
Flexible Cable Min / Max (Bottom)		0.75 mm <sup>2</sup> / 25 mm <sup>2</sup>
Torque (Top / Bottom)		4.5 / 4.5 Nm
Busbar	Connection Top	Pin
	Connection Bottom	Fork / Pin

## Physical

Dimensions (H x W x D)	1P	86 x 18 x 76 mm
	2P	86 x 36 x 76 mm
	3P	86 x 54 x 76 mm
Weight		0.12 / 0.24 / 0.36 kg
Package		12 module

## Short-Circuit Capacity AC

IEC 60898	I <sub>cn</sub>	1P	230 / 400 V	6	
		2P	230 / 400 V	6	
		3P / 4P	230 / 400 V	6	
I <sub>cs (Service)</sub>		% I <sub>cn</sub>		100	
IEC 60947-2	I <sub>cu (Ultimate)</sub>	1P	127 V	20	
			240 V	10	
			415 V	3	
		2P	127 V	30	
			240 V	20	
			415 V	10	
	3P / 4P	240 V	20		
		415 V	10		
	I <sub>cs (Service)</sub>		% I <sub>cu</sub>		75
	NEMA AB1 (120 / 240 V)				20

## Short-Circuit Capacity DC

IEC 60947-2	I <sub>cu (Ultimate)</sub>	1P	≤ 60 V	20
			≤ 220 V	
		2P	≤ 125 V	25
			≤ 440 V	
I <sub>cs (Service)</sub>		% I <sub>cu</sub>		100

## C-Curve Characteristics

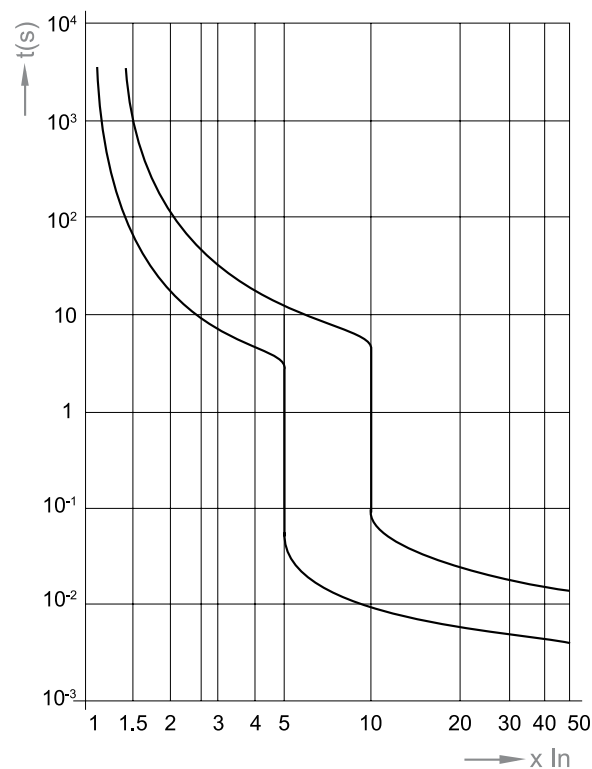

## D-Curve Characteristics

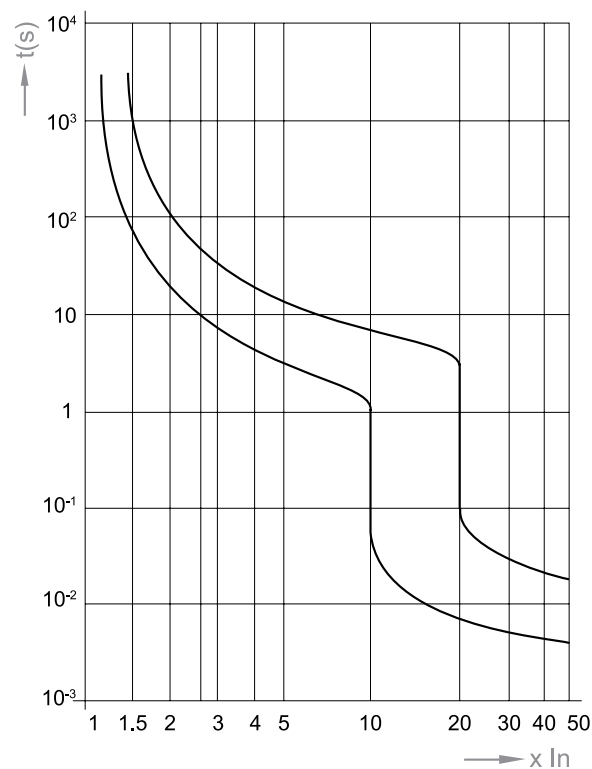



### Let-through Energy $I^2 t$ (A<sup>2</sup> s) C-Curve

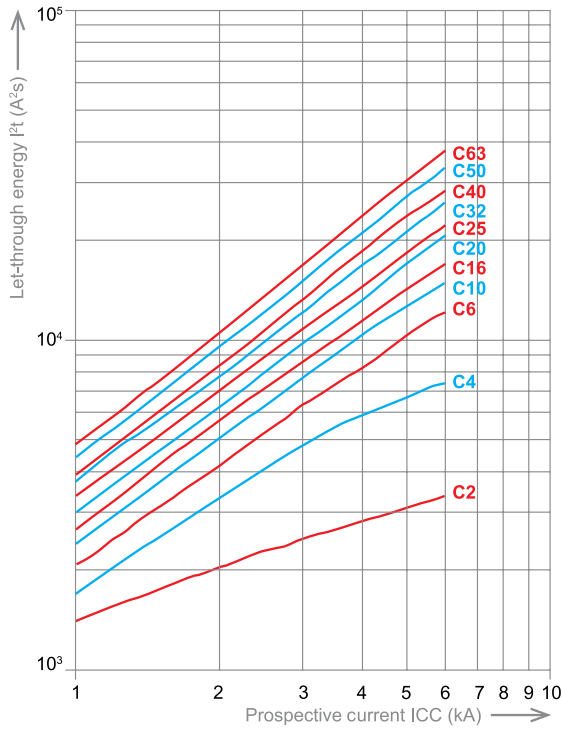

### Limited Peak Current (kA) at 230 / 400 V C-Curve

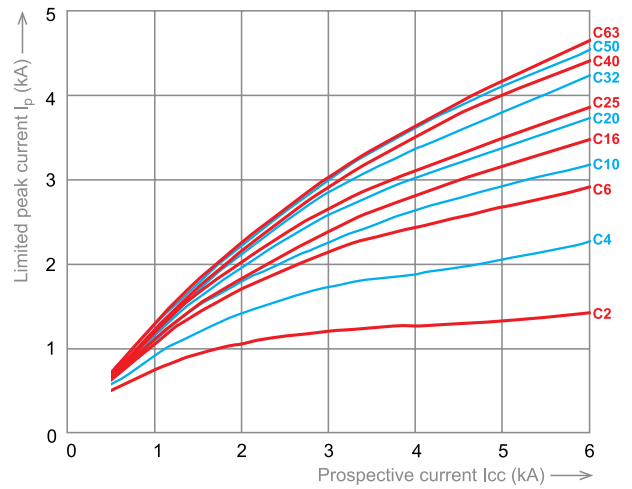

### Let-through Energy $I^2 t$ (A<sup>2</sup> s) D-Curve

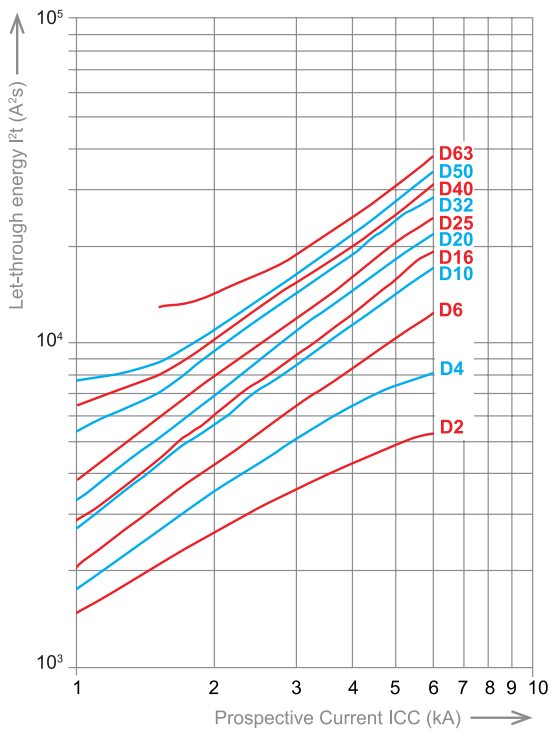

### Limited Peak Current (kA) at 230 / 400 V D-Curve

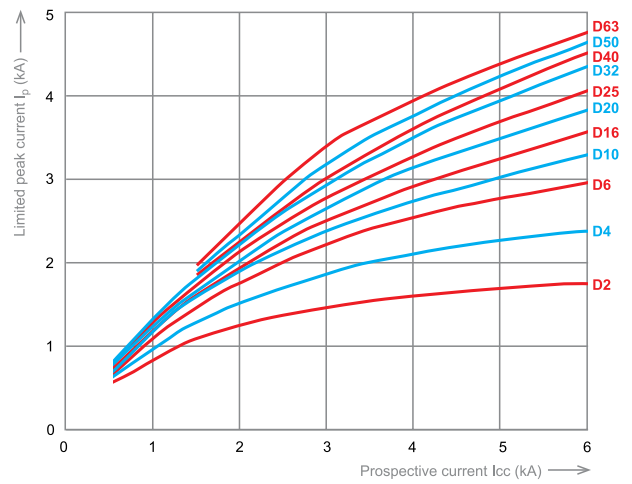

## Ambient Temperature Influence at 2-6 A

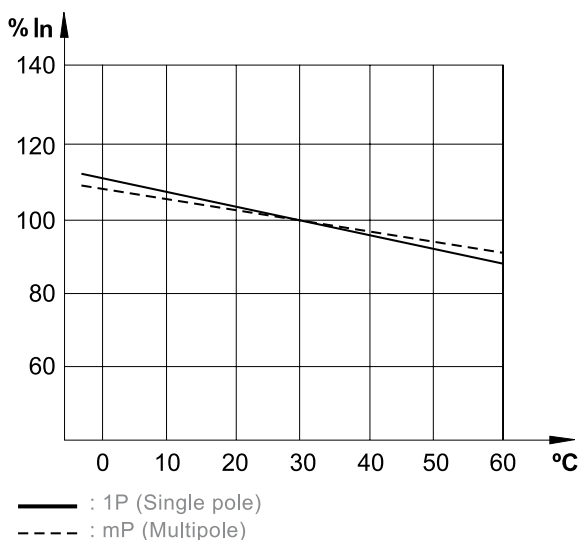

## Ambient Temperature Influence at 16-40 A

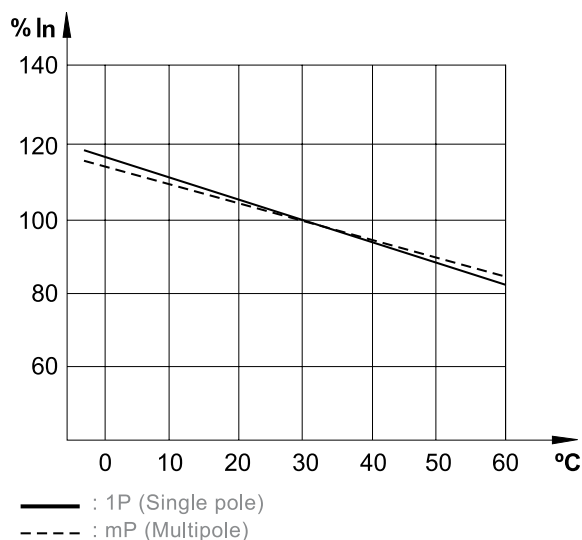

## Ambient Temperature Influence at 10 A

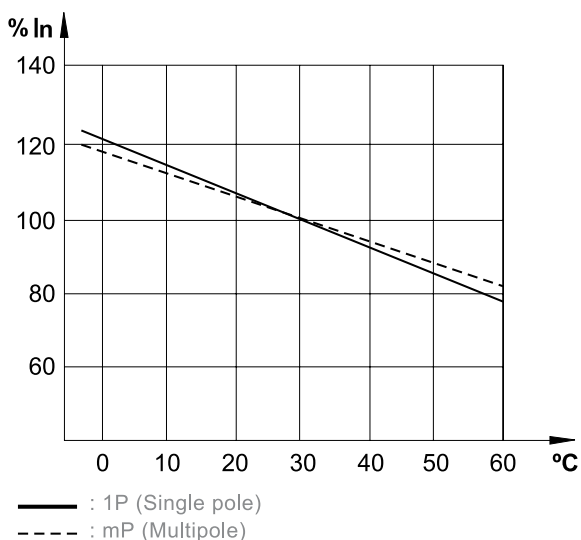

## Ambient Temperature Influence at 50-63 A

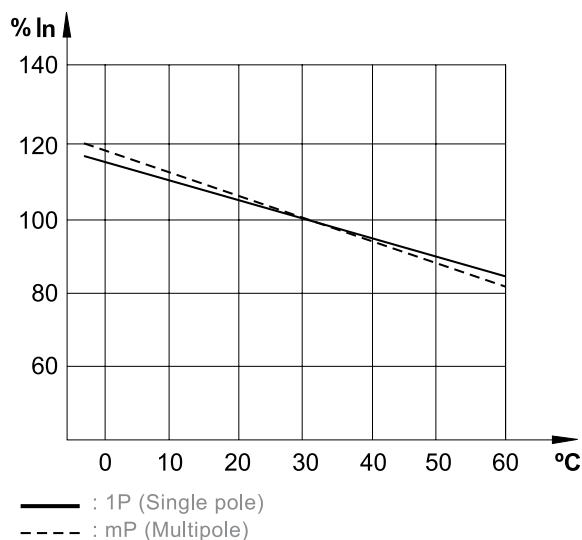



## Power Loss

In (A)	Voltage Drop (V)	Energy Loss Pw (W)	Resistance Z (mOhm)
0.5	2.23	1.12	4458.00
1	1.27	1.27	1272.00
2	0.62	1.24	310.00
3	0.52	1.56	173.00
4	0.37	1.49	93.00
6	0.26	1.57	43.60
8	0.16	1.24	19.40
10	0.16	1.56	15.60
13	0.16	2.01	11.90
16	0.16	2.57	10.10
20	0.14	2.76	6.90
25	0.13	3.19	5.10
32	0.10	3.07	3.00
40	0.10	4.00	2.50
50	0.09	4.50	1.80
63	0.08	5.16	1.30



# DIN-T6 2-in-1



- ✓ High speed and rapid arc quenching technology ensuring the highest level of protection is provided
- ✓ DIN rail mounting
- ✓ Free tripping mechanism even if toggle is locked ON or OFF
- ✓ Complies with AS/NZS 60898
- ✓ DIN-T6 2-in-1 MCBs feature 6 kA short circuit rating
- ✓ C-Curve For general purpose light and power applications
- ✓ Saves up to 50% of space
- ✓ Suits pole-covers and loadcentres
- ✓ Approval No. NSW24783 or RCM



## General

Tripping Characteristics	C
Nominal Current Rating at 30 °C	2 - 40 A
Poles	1P + 1P / 2P / 3P / 4P
Neutral Pole Protected	Yes

## Short Circuit

Icn 230 / 400 V 1P + 1P / 2P / 3P / 4P	6 / 6 / 6 kA
--	--------------

## Voltage

Nominal Voltage Un	AC	1P	240 V AC
		3P / 4P	415 V AC
	DC	1P	-
		2P (In Series)	96 V DC

Frequency	50 / 60 Hz
Maximum Service Voltage Ubmax	250 / 440 V AC 53 / 120 V DC
Minimum Service Voltage Ubmin	12 V AC

## Connections

Maximum Cable Size	Rigid / Flexible (Top)	16 mm <sup>2</sup> / 10 mm <sup>2</sup>
	Rigid / Flexible (Bottom)	16 mm <sup>2</sup> / 10 mm <sup>2</sup>

## Application



Residential and Commercial light and power applications when space is limited. Suitable for use in pole-covers, loadcentres and accessory modules utilising pin busbar comb.

## Design Considerations

1P+1P: Both poles must be from the same phase.

## Dimensions

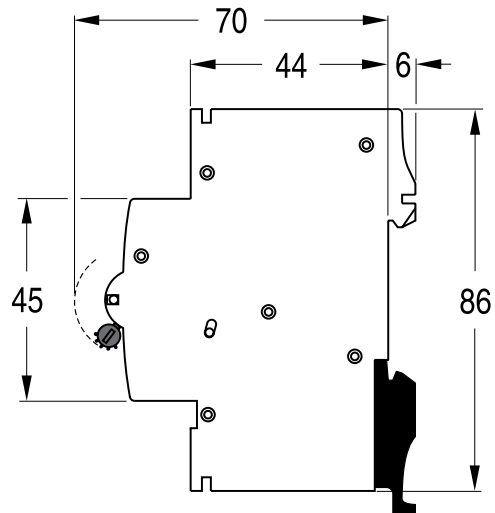
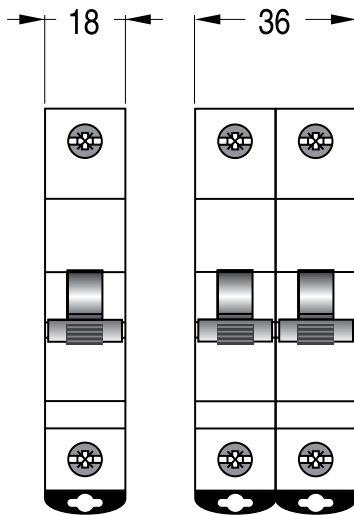

## 1 Pole + 1 Pole

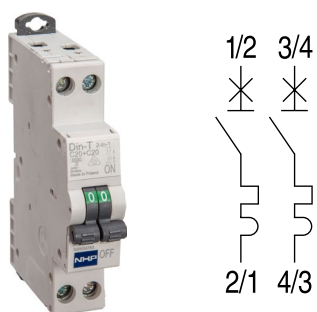

## 2 Pole

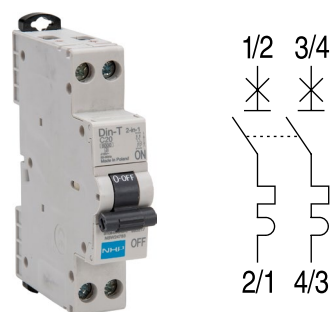

Width 18 mm

Amps (In) C-Curve (5-10 In)

2 DTCBD61102C

4 DTCBD61104C

6 DTCBD61106C

10 DTCBD61110C

16 DTCBD61116C

20 DTCBD61120C

25 -

32 -

40 -

Width 18 mm

Amps (In) C-Curve (5-10 In)

2 DTCBD6202C

4 DTCBD6204C

6 DTCBD6206C

10 DTCBD6210C

16 DTCBD6216C

20 DTCBD6220C

25 DTCBD6225C

32 DTCBD6232C

40 DTCBD6240C

## 3 Pole

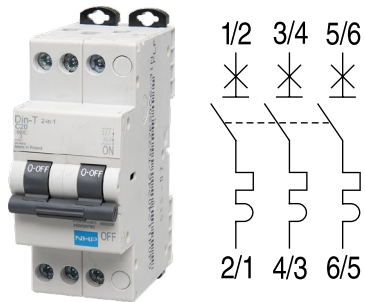

## 4 Pole

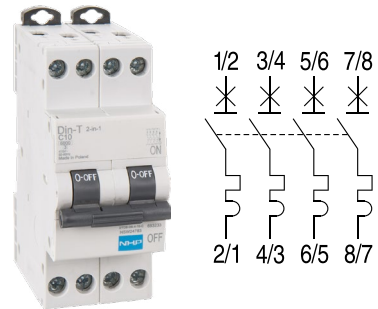

Width 36 mm

Amps (In) C-Curve (5-10 In)

2 DTCBD6302C

4 DTCBD6304C

6 DTCBD6306C

10 DTCBD6310C

16 DTCBD6316C

20 DTCBD6320C

25 DTCBD6325C

32 DTCBD6332C

40 DTCBD6340C

Width 36 mm

Amps (In) C-Curve (5-10 In)

2 DTCBD6402C

4 DTCBD6404C

6 DTCBD6406C

10 DTCBD6410C

16 DTCBD6416C

20 DTCBD6420C

25 DTCBD6425C

32 DTCBD6432C

40 DTCBD6440C

## Voltage Ratings

Nominal Voltage Un	AC	1P	240 V AC
		3P / 4P	415 V AC
	DC	1P	-
		2P (In Series)	96 V DC
Frequency	50 / 60 Hz		
	DC : 1.4 x mag. trip		
	400 Hz : 1.5 x mag. trip		
Maximum Service Voltage Ubmax		250 / 440 V AC 53 / 120 V DC	
Minimum Service Voltage Ubmin		12	
Selectivity Class (IEC 60898)		A	
Isolator Application	IEC 60947-2	Yes	
Rated Insulation Voltage	Pollution Degree 2	500 V	
	Pollution Degree 3	440 V	
Impulse Withstand Test Voltage		6 kV	
Insulation Resistance		10000 mOhm	
Dielectric Rigidity		2.5 kV	

## Environmental

Vibration Resistance (IEC 77 / 16.3) (in x, y, z direction)		3 g
Endurance	Electrical at Un, In	10000 cycles
	Mechanical	20000 cycles
Utilisation Category (IEC 60947-2)		A
Protection Degree	Outside	IP20
	Inside	IP40
Self-extinguish Degree (According to UL94)		UL 94 V-2
Tropicalisation (IEC60068-2 / DIN 40046)		+55 °C / 95 % RH
Operating Temperature		-25 °C / +55 °C
Storage Temperature		-55 °C / +55 °C

## Connection

Rigid Cable Min / Max (Top)		1 mm <sup>2</sup> / 16 mm <sup>2</sup>
Flexible Cable Min / Max (Top)		1 mm <sup>2</sup> / 10 mm <sup>2</sup>
Rigid Cable Min / Max (Bottom)		1 mm <sup>2</sup> / 16 mm <sup>2</sup>
Flexible Cable Min / Max (Bottom)		1 mm <sup>2</sup> / 10 mm <sup>2</sup>
Torque (Top / Bottom)		3 / 3 Nm
Busbar	Connection Top	Pin
	Connection Bottom	Pin

## Physical

Dimensions (H x W x D)	1P + 1P	86 x 18 x 76 mm
	2P	86 x 18 x 76 mm
	3P	86 x 36 x 76 mm
	4P	86 x 36 x 76 mm
Weight		0.16 / 0.32 kg
Package		12 module



### Short-Circuit Capacity AC

IEC 60898	Icn	1P	230 / 400 V	6
		2P	230 / 400 V	6
		3P / 4P	230 / 400 V	6
Ics (Service)		% Icn	100	
IEC 60947-2	Icu (Ultimate)	1P	127 V	-
			240 V	6
			415 V	-
		2P	127 V	-
			240 V	-
			415 V	10
	3P / 4P	240 V	-	
		415 V	6	
		440 V	-	
	Ics (Service)		% Icu	-
NEMA AB1 (120 / 240 V)				

### C-Curve Characteristics

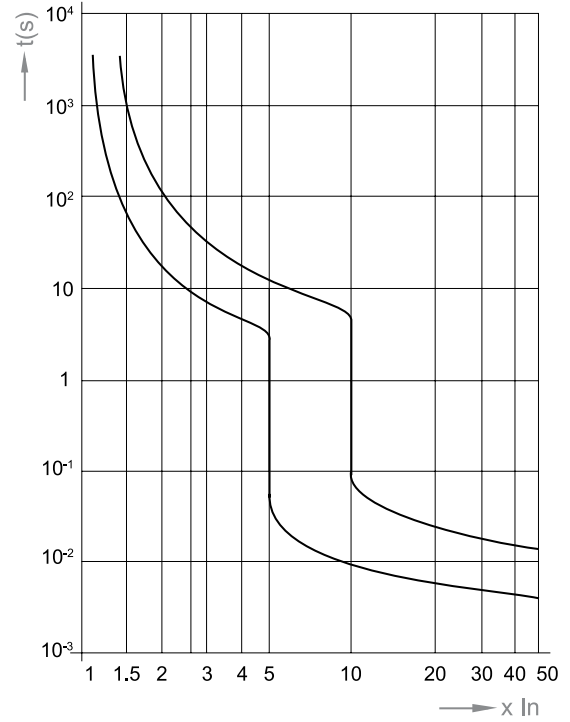

### Short-Circuit Capacity DC

IEC 60947-2	Icu (Ultimate)	1P	$\leq 60$ V	-
		2P	$\leq 220$ V	-
			$\leq 125$ V	-
		Ics (Service)	$\leq 440$ V	-
% Icu	-			

### Let-through Energy $I^2 t$ ( $A^2 s$ ) C-Curve

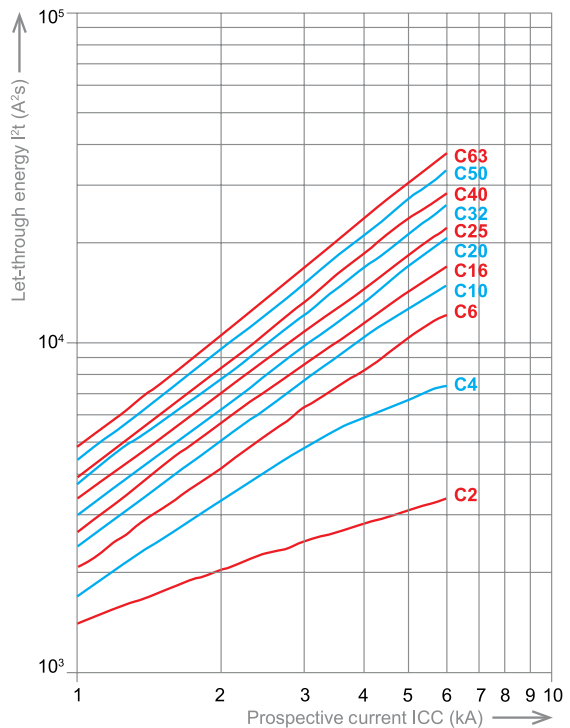



MCBs and RCBOs

### Limited Peak Current (kA) at 230 / 400 V C-Curve

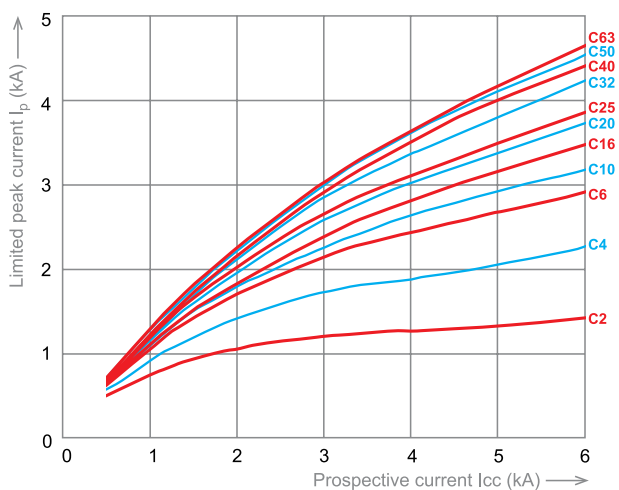

### Ambient Temperature Influence at 10 A

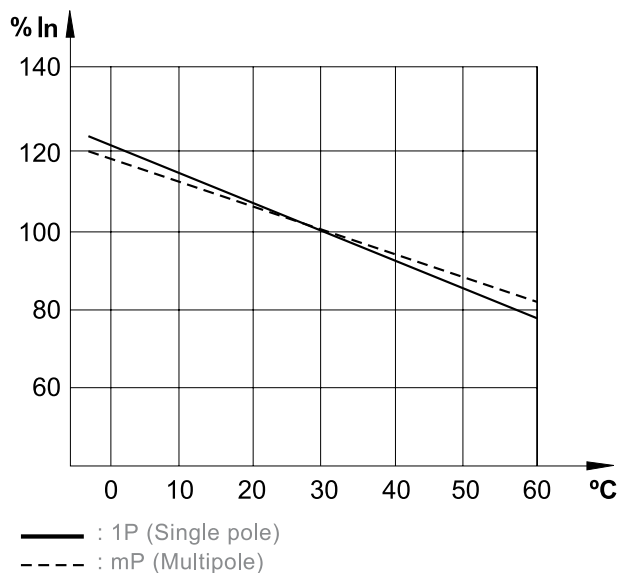

### Ambient Temperature Influence at 0.5 - 6 A

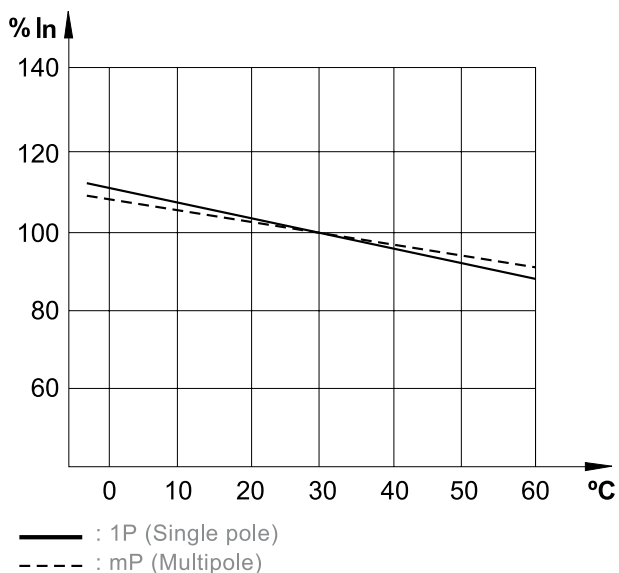

### Ambient Temperature Influence at 16-40 A

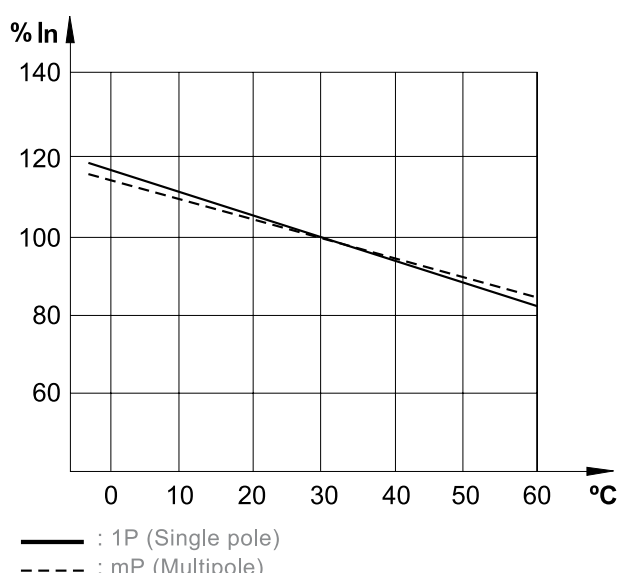



## Power Loss

In (A)	Voltage Drop (V)	Energy Loss Pw (W)	Resistance Z (mOhm)
2	0.55	1.10	275.00
4	0.34	1.35	84.38
6	0.25	1.52	42.22
10	0.16	1.64	16.40
16	0.13	2.10	8.20
20	0.13	2.52	6.30
25	0.12	3.10	4.96
32	0.12	3.80	3.71
40	0.11	4.46	2.79



# DIN-T6 Easy Fit



- ✓ High speed and rapid arc quenching technology ensuring the highest level of protection is provided
- ✓ DIN rail mounting
- ✓ Free tripping mechanism even if toggle is locked ON or OFF
- ✓ Complies with AS/NZS 60898
- ✓ DIN-T Easy-Fit MCBs feature 6 kA short circuit rating
- ✓ Cable clamping technology
- ✓ 6 to 63 A Models – Plug in busbar comb or screw connection “line-side” connection
- ✓ 6 to 20 A Models – Screw-less cable clamping “load-side” connection
- ✓ 25 to 63 A Models – Screw “load-side” connection
- ✓ C-Curve for general purpose light and power applications
- ✓ Approval No. NSW24022 or RCM



## General

Tripping Characteristics	C
Nominal Current Rating At 30 °C	6 - 63 A
Poles	1P / 3P

## Short Circuit

Icn 230 / 400V 1P / 3P	6 / 6 kA
------------------------	----------

## Voltage

Nominal Voltage Un	AC	1P	240, 415 V AC
		3P / 4P	415 V AC
	DC	1P	48 V DC
		2P (In Series)	110 V DC
Frequency	50 / 60 Hz		
Maximum Service Voltage U <sub>max</sub>	250 / 440 V AC 53 / 120 V DC		
Minimum Service Voltage U <sub>min</sub>	12 V AC		

## Connections

Maximum Cable Size	Rigid / Flexible (Top)	35 mm <sup>2</sup> / 25 mm <sup>2</sup>
	Rigid / Flexible (Bottom)	25 mm <sup>2</sup> / 16 mm <sup>2</sup>

## Application



Commercial, industrial light and power applications when you are after quick fit-out or where vibration exists.

## Dimensions

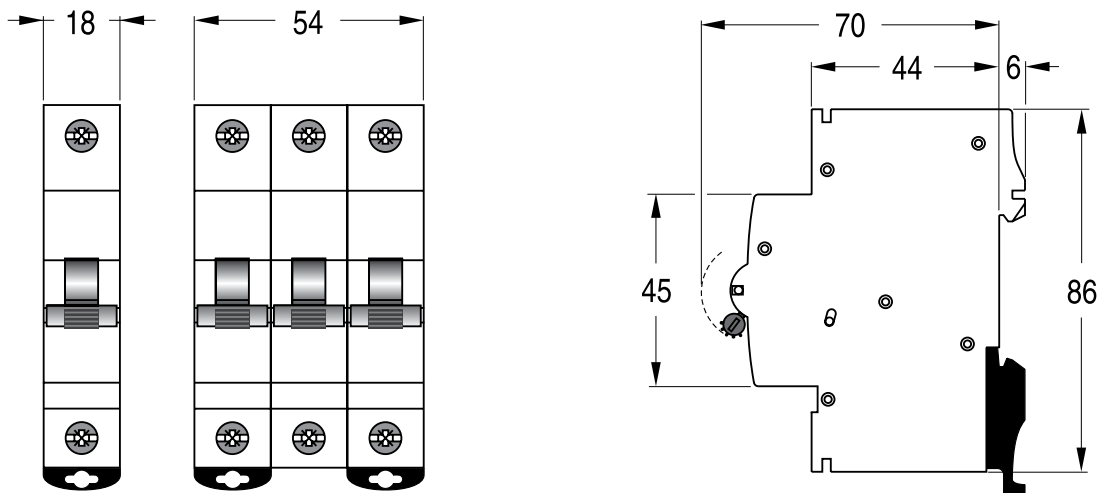

## 1 Pole



Width 18 mm

## 3 Pole

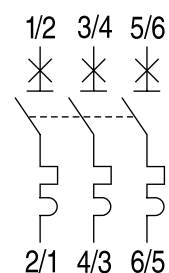

Width 54 mm

Amps (In)

C - Curve (5-10 In)

6	DTCBE6106C
10	DTCBE6110C
16	DTCBE6116C
20	DTCBE6120C
25	DTCBE6125C
32	DTCBE6132C
40	DTCBE6140C
50	DTCBE6150C
63	DTCBE6163C

Amps (In)

C - Curve (5-10 In)

6	DTCBE6306C
10	DTCBE6310C
16	DTCBE6316C
20	DTCBE6320C
25	DTCBE6325C
32	DTCBE6332C
40	DTCBE6340C
50	DTCBE6350C
63	DTCBE6363C

## Voltage Ratings

Nominal Voltage $U_n$	AC	1P	240, 415 V AC
		3P / 4P	415 V AC
	DC	1P	48 V DC
		2P (In Series)	110 V DC
Frequency	50 / 60 Hz		
	DC : 1.4 x mag. trip		
	400Hz : 1.5 x mag. trip		
Maximum Service Voltage $U_{bmax}$	250 / 440 V AC 53 / 120 V DC		
Minimum Service Voltage $U_{bmin}$	12		
Selectivity Class (IEC 60898)	A		
Isolator Application	IEC 60947-2	Yes	
Rated Insulation Voltage	Pollution Degree 2	500 V	
	Pollution Degree 3	440 V	
Impulse Withstand Test Voltage	6 kV		
Insulation Resistance	10000 mOhm		
Dielectric Rigidity	2.5 kV		

## Environmental

Vibration Resistance (IEC 77 / 16.3) (in x, y, z direction)	3 g	
Endurance	Electrical at $U_n, I_n$	10000 cycles
	Mechanical	20000 cycles
Utilisation Category (IEC 60947-2)	A	
Protection Degree	Outside	IP20
	Inside	IP40
Self-extinguish Degree (According to UL94)	UL 94 V-2	
Tropicalisation (IEC60068-2 / DIN 40046)	+55 °C / 95 % RH	
Operating Temperature	-25 °C / +55 °C	
Storage Temperature	-55 °C / +55 °C	

## Connection

Rigid Cable Min / Max (Top)	1 mm <sup>2</sup> / 35 mm <sup>2</sup>	
Flexible Cable Min / Max (Top)	0.75 mm <sup>2</sup> / 25 mm <sup>2</sup>	
Rigid Cable Min / Max (Bottom)	1 mm <sup>2</sup> / 25 mm <sup>2</sup>	
Flexible Cable Min / Max (Bottom)	0.75 mm <sup>2</sup> / 16 mm <sup>2</sup>	
Torque (Top / Bottom)	2.5 / 2.5 Nm	
Busbar	Connection Top	-
	Connection Bottom	Pin

## Physical

Dimensions (H x W x D)	1P	86 x 18 x 76 mm
	3P	86 x 54 x 76 mm
Weight	0.125 / 0.375 kg	
Package	12 module	



## Short-Circuit Capacity AC

IEC 60898	I <sub>cn</sub>	1P	230 / 400 V	6
		2P	230 / 400 V	-
		3P / 4P	230 / 400 V	6
I <sub>cs (Service)</sub>		% I <sub>cn</sub>		100
IEC 60947-2	I <sub>cu (Ultimate)</sub>	1P	127 V	20
			240 V	10
			415 V	7
		2P	127 V	-
			240 V	-
			415 V	-
		3P / 4P	240 V	20
			415 V	10
			440 V	6
			I <sub>cs (Service)</sub>	% I <sub>cu</sub>
NEMA AB1 (120 / 240 V)				-

## C-Curve Characteristics

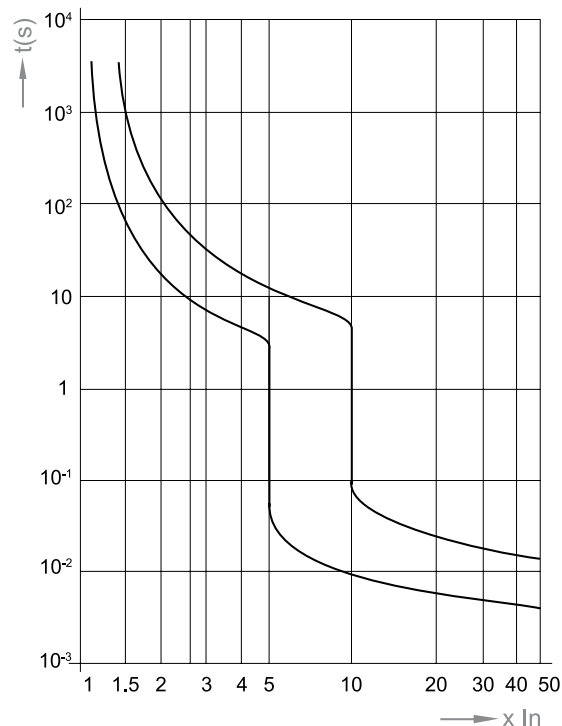

## Short-Circuit Capacity DC

IEC 60947-2	I <sub>cu (Ultimate)</sub>	1P	$\leq 60$ V	20
			$\leq 220$ V	-
		2P	$\leq 125$ V	25
			$\leq 440$ V	-
	I <sub>cs (Service)</sub>		% I <sub>cu</sub>	

## Let-through Energy $I^2 t$ (A<sup>2</sup> s) C-Curve

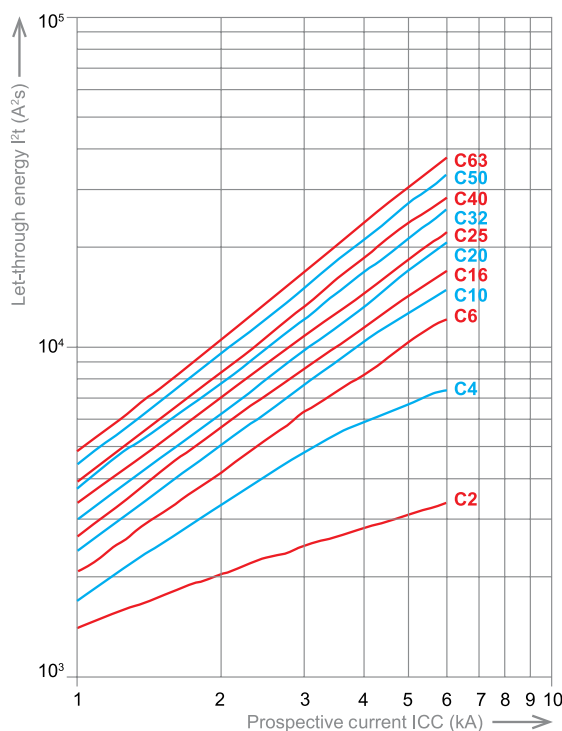

MCBs and RCBOs



### Limited Peak Current (kA) at 230 / 400 V C-Curve

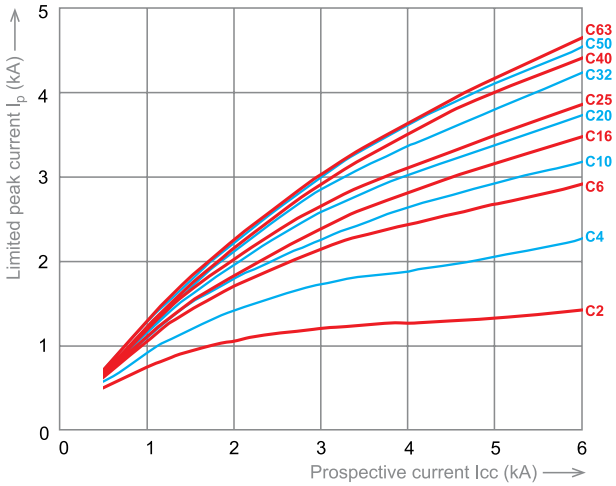

### Ambient Temperature Influence at 10 A

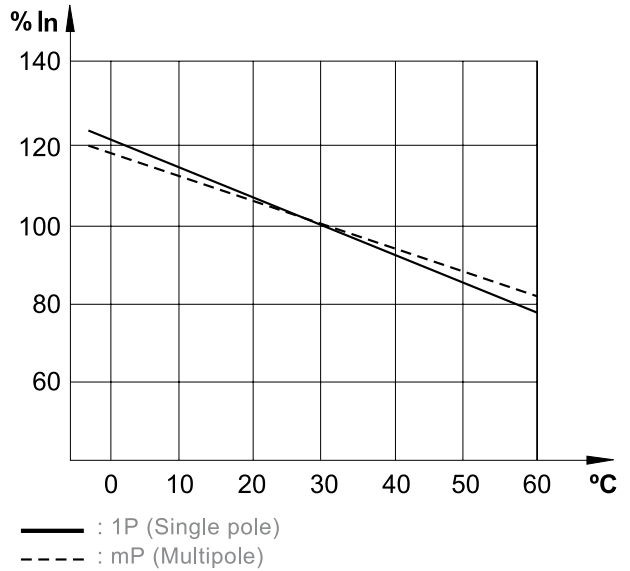

### Ambient Temperature Influence at 6 A

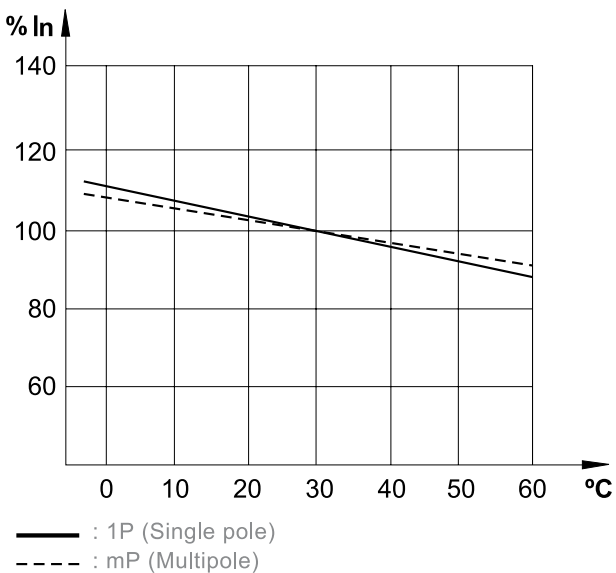

### Ambient Temperature Influence at 16-40 A

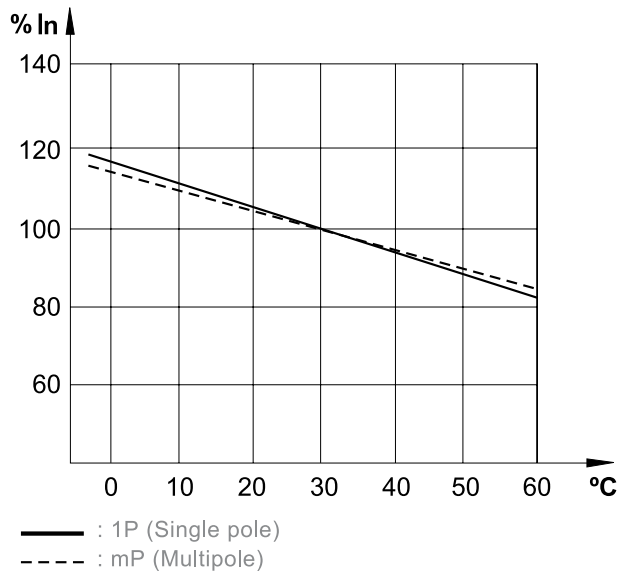

## Ambient Temperature Influence at 50-63 A

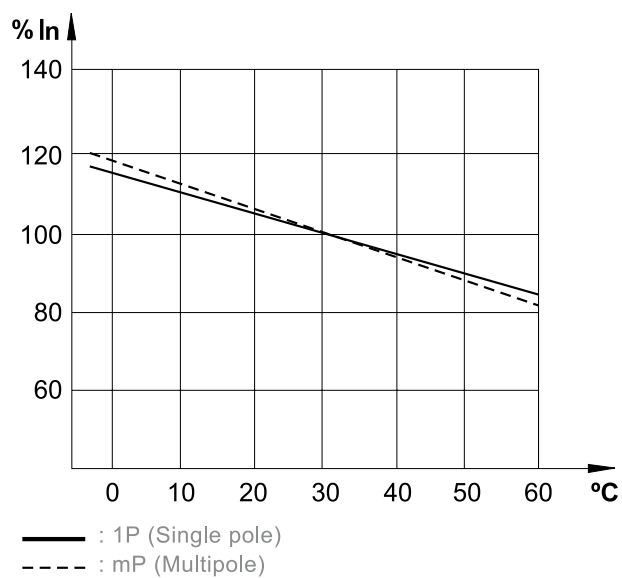

## Power Loss

In (A)	Voltage Drop (V)	Energy Loss Pw (W)	Resistance Z (mOhm)
0.5	2.23	1.12	4458.00
1	1.27	1.27	1272.00
2	0.62	1.24	310.00
3	0.52	1.56	173.00
4	0.37	1.49	93.00
6	0.26	1.57	43.60
8	0.16	1.24	19.40
10	0.16	1.56	15.60
13	0.16	2.01	11.90
16	0.16	2.57	10.10
20	0.14	2.76	6.90
25	0.13	3.19	5.10
32	0.10	3.07	3.00
40	0.10	4.00	2.50
50	0.09	4.50	1.80
63	0.08	5.16	1.30

# DIN-T DC Series



- ✓ High speed and rapid arc quenching technology ensuring the highest level of protection is provided
- ✓ DIN rail mounting
- ✓ Free tripping mechanism even if toggle is locked ON or OFF
- ✓ Complies with AS/NZS 60898
- ✓ DIN-T DC MCBs feature 6 kA short circuit rating
- ✓ C-Curve tripping characteristic
- ✓ Pad lockable and sealable toggle restricts unauthorized action
- ✓ Polarity sensitive
- ✓ Large capacity terminals
- ✓ Fast connection pin / fork busbar comb or NC or GB busbar chassis
- ✓ Suits pole-covers, loadcentres and the Concept range of Panelboards
- ✓ Approval No. NSW24265 or RCM



## General

Tripping Characteristics	B, C
Nominal Current Rating At 30 °C	0.5 - 63 A
Poles	1P / 2P / 4P

## Short Circuit

Icn 230 / 400V 1P / 2P / 4P	6 / 6 / 6 kA
-----------------------------	--------------

## Voltage

Nominal Voltage Un	AC	1P	240, 415 V AC
		3P / 4P	415 V AC
	DC	1P	250 V DC
		2P (In Series)	500 V DC
Frequency	50 / 60 Hz		
Maximum Service Voltage U <sub>max</sub>	250 / 440 V AC 250 / 500 / 880 V DC		
Minimum Service Voltage U <sub>min</sub>	12 V AC		

## Connections

Maximum Cable Size	Rigid / Flexible (Top)	35 mm <sup>2</sup> / 25 mm <sup>2</sup>
	Rigid / Flexible (Bottom)	35 mm <sup>2</sup> / 25 mm <sup>2</sup>





## Dimensions

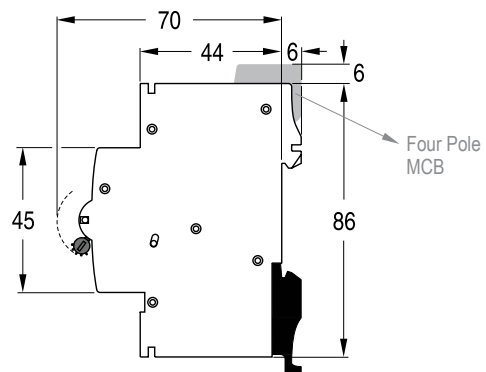
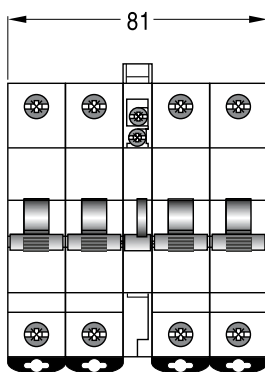
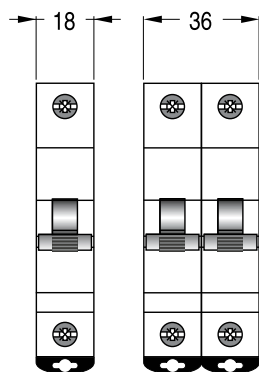

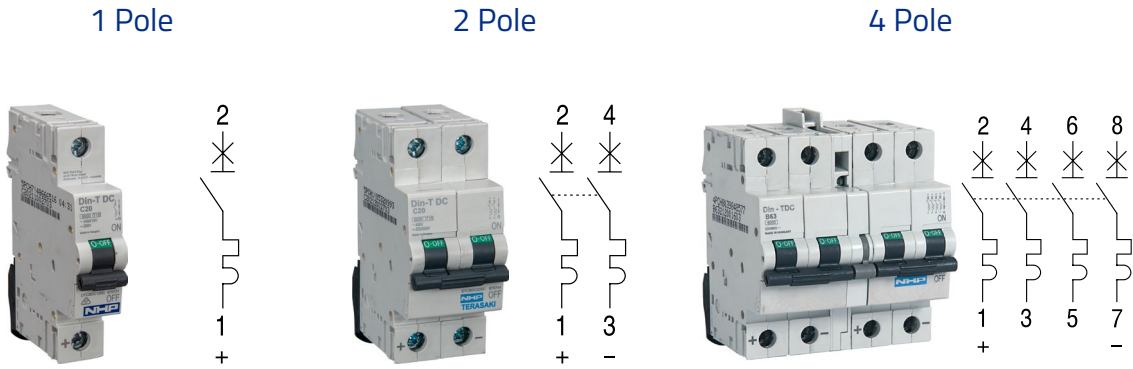

Width	18 mm	36 mm	81 mm
Amps (In)	C-Curve (5-10 In)	C-Curve (5-10 In)	B-Curve (3-5 In)

0.5	DTCBDC105C	-	-
1	DTCBDC101C	DTCBDC201C	-
2	DTCBDC102C	DTCBDC202C	-
4	DTCBDC104C	DTCBDC204C	-
6	DTCBDC106C	DTCBDC206C	-
10	DTCBDC110C	DTCBDC210C	DTCBDC410B
16	DTCBDC116C	DTCBDC216C	DTCBDC416B
20	DTCBDC120C	DTCBDC220C	DTCBDC420B
25	DTCBDC125C	DTCBDC225C	-
32	DTCBDC132C	DTCBDC232C	-
40	DTCBDC140C	DTCBDC240C	DTCBDC440B
50	DTCBDC150C	DTCBDC250C	-
63	DTCBDC163C	DTCBDC263C	-



## Voltage Ratings

Nominal Voltage Un	AC	1P	240, 415 V AC
		3P / 4P	415 V AC
	DC	1P	250 V DC
		2P (In Series)	500 V DC
Frequency	50 / 60 Hz		
	DC: 1.4 x mag. trip		
	400Hz: 1.5 x mag. trip		
Maximum Service Voltage Ubmax		250 / 440 V AC 250 / 500 / 880 V DC	
Minimum Service Voltage Ubmin		12	
Selectivity Class (IEC 60898)		A	
Isolator Application	IEC 60947-2	Yes	
Rated Insulation Voltage	Pollution Degree 2	500 V	
	Pollution Degree 3	440 V	
Impulse Withstand Test Voltage		6 kV	
Insulation Resistance		10000 mOhm	
Dielectric Rigidity		2.5 kV	

## Environmental

Vibration Resistance (IEC 77 / 16.3) (in x, y, z direction)		5 g
Endurance	Electrical at Un, In	1000 cycles
	Mechanical	20000 cycles
Utilisation Category (IEC 60947-2)		A
Protection Degree	Outside	IP20
	Inside	IP40
Self-extinguish Degree (According to UL94)		UL 94 V-2
Tropicalisation (IEC60068-2 / DIN 40046)		+55 °C / 95 % RH
Operating Temperature		-25 °C / +55 °C
Storage Temperature		-55 °C / +55 °C

## Connection

Rigid Cable Min / Max (Top)		1 mm <sup>2</sup> / 35 mm <sup>2</sup>
Flexible Cable Min / Max (Top)		0.75 mm <sup>2</sup> / 25 mm <sup>2</sup>
Rigid Cable Min / Max (Bottom)		1 mm <sup>2</sup> / 35 mm <sup>2</sup>
Flexible Cable Min / Max (Bottom)		0.75 mm <sup>2</sup> / 25 mm <sup>2</sup>
Torque (Top / Bottom)		4.5 / 4.5 Nm
Busbar	Connection Top	Fork / Pin
	Connection Bottom	Fork / Pin

## Physical

Dimensions (H x W x D)	1P	86 x 18 x 76 mm
	2P	86 x 36 x 76 mm
	4P	86 x 81 x 76 mm
Weight	0.125 kg	
Package	12 module	



### Short-Circuit Capacity AC

IEC 60898	Icn	1P	230 / 400 V	6
		2P	230 / 400 V	6
		3P / 4P	230 / 400 V	6
Ics (Service)		% Icn		100
IEC 60947-2	Icu (Ultimate)	1P	127 V	
			240 V	6
			415 V	
		2P	127 V	
			240 V	
			415 V	6
		3P / 4P	240 V	
			415 V	
			440 V	
			Ics (Service)	% Icu
NEMA AB1 (120 / 240 V)				

### C-Curve Characteristics (AC only)

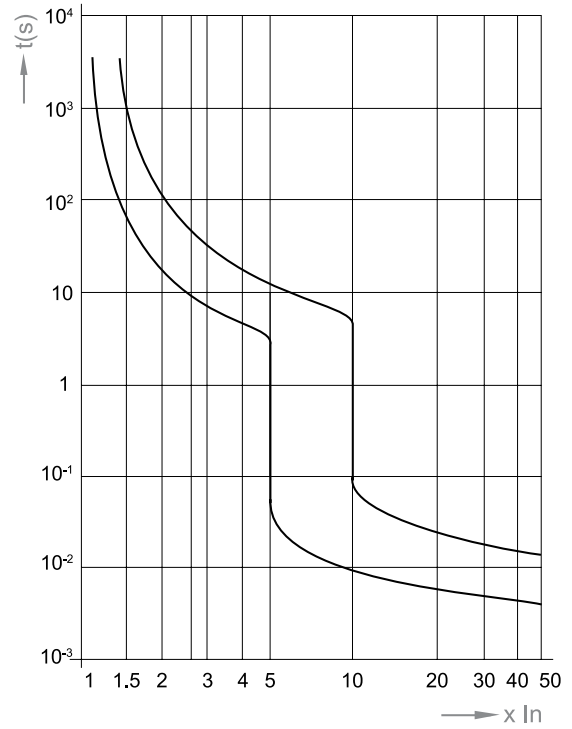

### Short-Circuit Capacity DC

IEC 60947-2	Icu (Ultimate)	1P	≤ 60 V	10
			≤ 220 V	20
		2P	≤ 125 V	10
			≤ 440 V	
			Ics (Service)	% Icu

### B-Curve Characteristics (AC only)

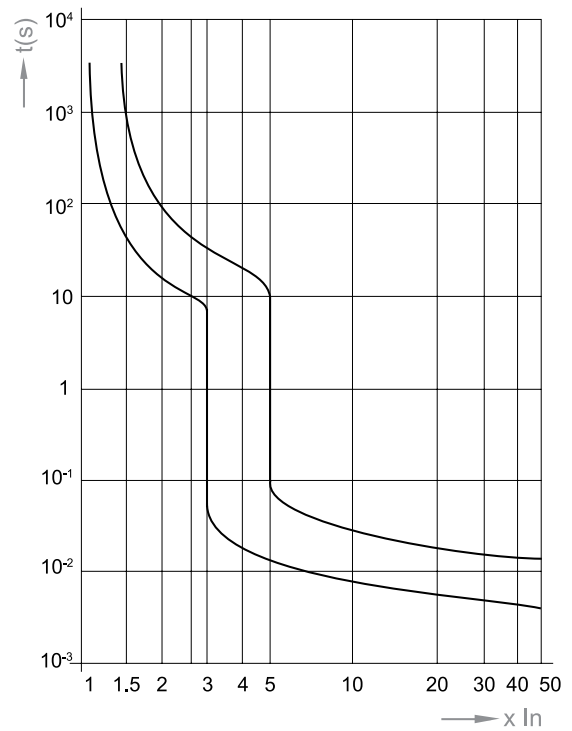

## Ambient Temperature Influence at 0.5 - 6 A

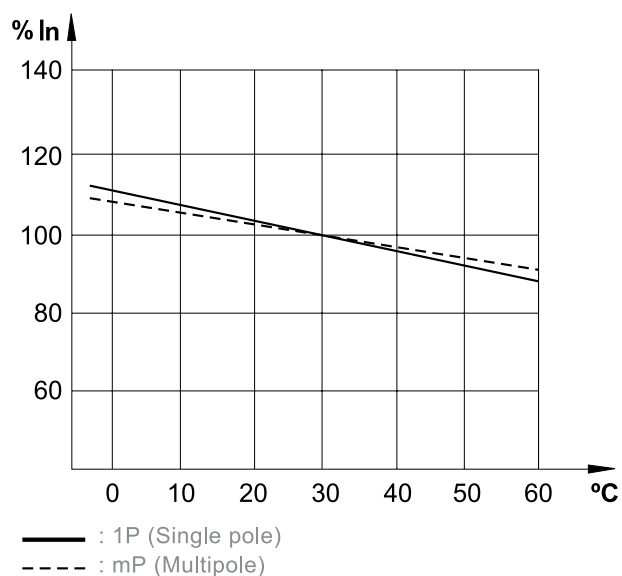

## Ambient Temperature Influence at 16-40 A

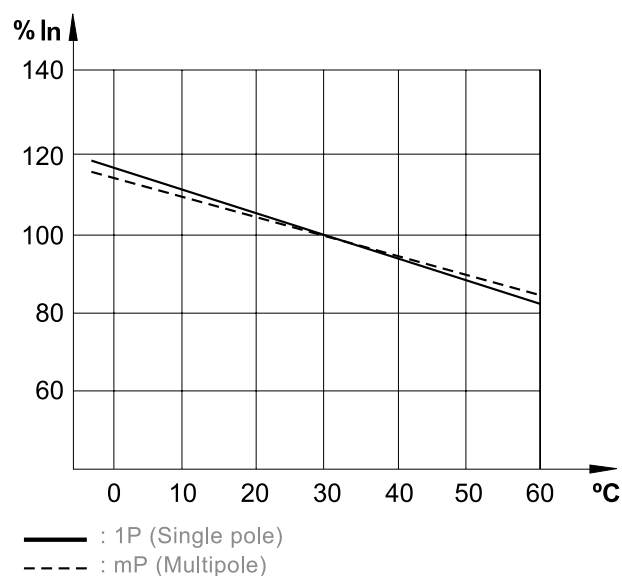

## Ambient Temperature Influence at 10 A

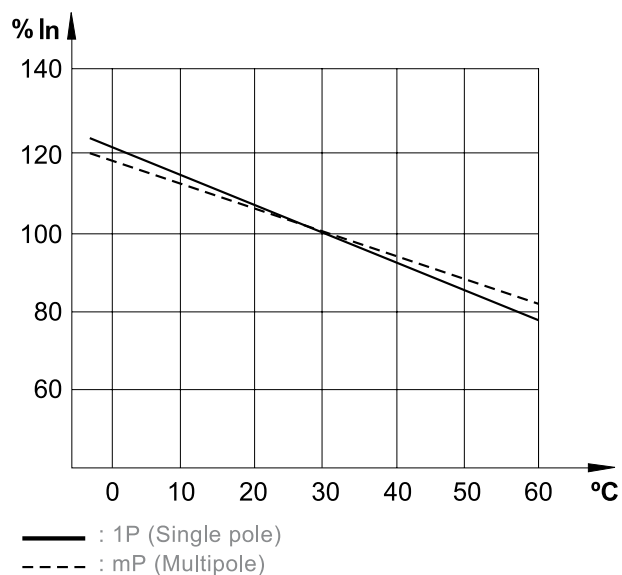

## Ambient Temperature Influence at 50-63 A

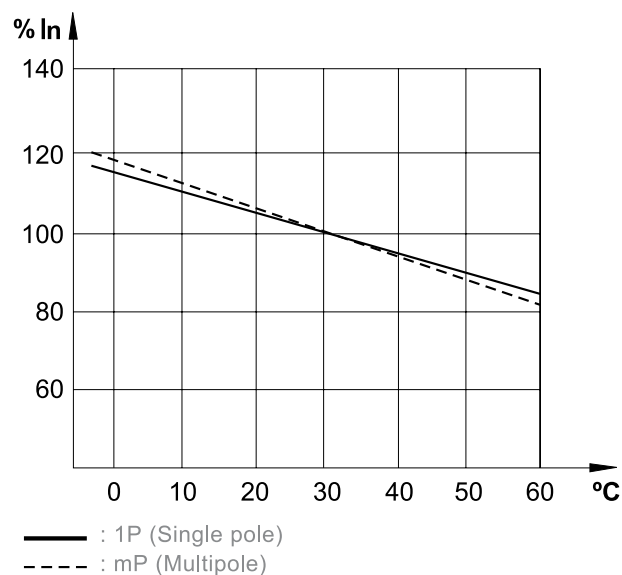



## Power Loss

In (A)	Voltage Drop (V)	Energy Loss Pw (W)	Resistance Z (mOhm)
0.5	2.23	1.12	4458.00
1	1.27	1.27	1272.00
2	0.62	1.24	310.00
3	0.52	1.56	173.00
4	0.37	1.49	93.00
6	0.26	1.57	43.60
8	0.16	1.24	19.40
10	0.16	1.56	15.60
13	0.16	2.01	11.90
16	0.16	2.57	10.10
20	0.14	2.76	6.90
25	0.13	3.19	5.10
32	0.10	3.07	3.00
40	0.10	4.00	2.50
50	0.09	4.50	1.80
63	0.08	5.16	1.30

# DIN-T10



- ✓ High speed and rapid arc quenching technology ensuring the highest level of protection is provided
- ✓ DIN rail mounting
- ✓ Free tripping mechanism even if toggle is locked ON or OFF
- ✓ Complies with AS/NZS 60898 and AS/NZS 60947-2 (as applicable)
- ✓ DIN-T10 MCBs feature 10kA short circuit rating
- ✓ B curve for long cable runs when fault loop impedance become an issue
- ✓ C curve for general light, power and motor starting applications
- ✓ D trip curve for high inrush, motor starting and transformer applications
- ✓ Pad lockable and sealable toggle restricts unauthorized action
- ✓ Large capacity terminals
- ✓ Fast connection pin / fork busbar comb or NC or GB busbar chassis
- ✓ Suits pole-covers, loadcentres and the Concept range of Panelboards
- ✓ Approval No. N17481 or RCM



## General

Tripping Characteristics	B, C, D
Nominal Current Rating At 30 °C	0.5 - 63 A
Poles	1P / 2P / 3P / 4P
Neutral Pole Protected	Yes

## Short Circuit

Icn 230 / 400 V 1P / 2P / 3P / 4P	10 / 10 / 10 kA
-----------------------------------	-----------------

## Voltage

Nominal Voltage Un	AC	1P	240, 415 V AC
		3P / 4P	415 V AC
	DC	1P	48 V DC
		2P (in series)	110 V DC

Frequency	50 / 60 Hz
-----------	------------

Maximum Service Voltage U <sub>max</sub>	250 / 440 V AC 53 / 120 V DC
--	---------------------------------

Minimum Service Voltage U <sub>min</sub>	12 V AC
--	---------

## Connections

Maximum Cable Size	Rigid / Flexible (Top)	35 mm <sup>2</sup> / 25 mm <sup>2</sup>
	Rigid / Flexible (Bottom)	35 mm <sup>2</sup> / 25 mm <sup>2</sup>

## Application

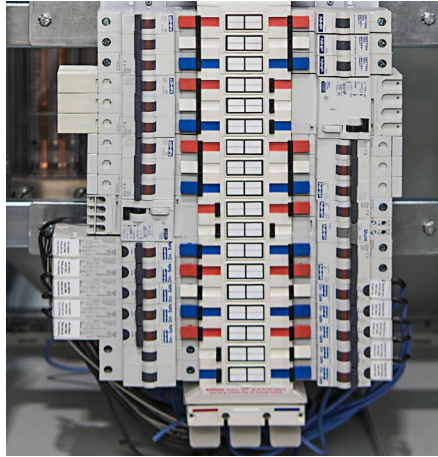

Commercial and industrial general light and power applications. Suitable for use in pole-covers, loadcentres utilising fork or pin busbar comb and the Concept range of Panelboards using busbar chassis.

## Dimensions

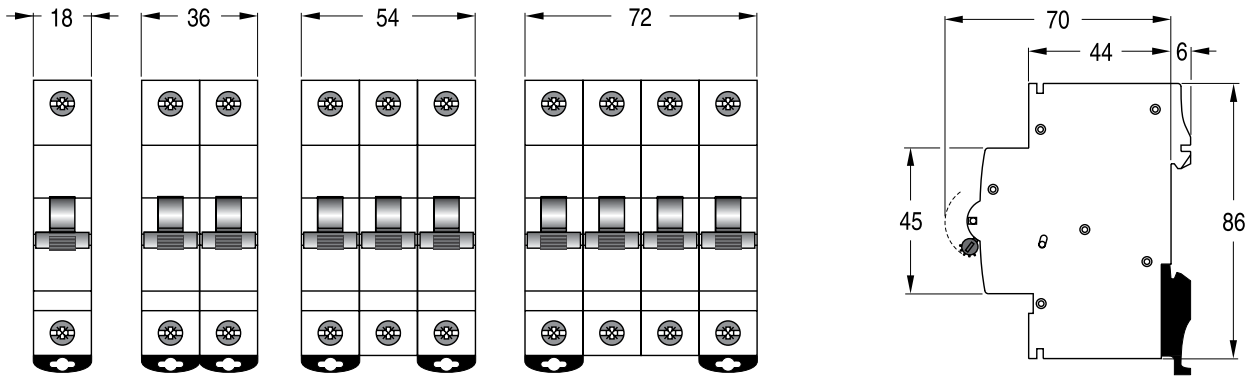



## 1 Pole

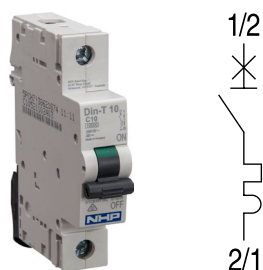

Width 18 mm

## 2 Pole

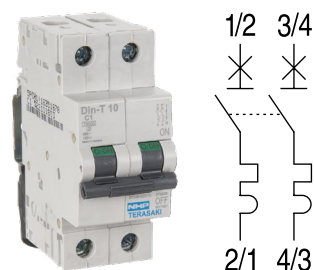

Width 36 mm

In (A)	B-Curve (3-5 In)	C-Curve (5-10 In)	D-Curve (10-20 In)
0.5	-	DTCB10105C	DTCB10105D
1	-	DTCB10101C	DTCB10101D
2	-	DTCB10102C	DTCB10102D
3	-	DTCB10103C	-
4	-	DTCB10104C	DTCB10104D
6	DTCB10106B	DTCB10106C	DTCB10106D
10	DTCB10110B	DTCB10110C	DTCB10110D
13	DTCB10113B	DTCB10113C	DTCB10113D
16	DTCB10116B	DTCB10116C	DTCB10116D
20	DTCB10120B	DTCB10120C	DTCB10120D
25	DTCB10125B	DTCB10125C	DTCB10125D
32	DTCB10132B	DTCB10132C	DTCB10132D
40	DTCB10140B	DTCB10140C	DTCB10140D
50	DTCB10150B	DTCB10150C	DTCB10150D
63	DTCB10163B	DTCB10163C	DTCB10163D

In (A)	B-Curve (3-5 In)	C-Curve (5-10 In)	D-Curve (10-20 In)
0.5	-	DTCB10205C	DTCB10205D
1	-	DTCB10201C	DTCB10201D
2	-	DTCB10202C	DTCB10202D
3	-	-	-
4	-	DTCB10204C	DTCB10204D
6	DTCB10206B	DTCB10206C	DTCB10206D
10	DTCB10210B	DTCB10210C	DTCB10210D
13	DTCB10213B	DTCB10213C	DTCB10213D
16	DTCB10216B	DTCB10216C	DTCB10216D
20	DTCB10220B	DTCB10220C	DTCB10220D
25	DTCB10225B	DTCB10225C	DTCB10225D
32	DTCB10232B	DTCB10232C	DTCB10232D
40	DTCB10240B	DTCB10240C	DTCB10240D
50	DTCB10250B	DTCB10250C	DTCB10250D
63	DTCB10263B	DTCB10263C	DTCB10263D

## 3 Pole

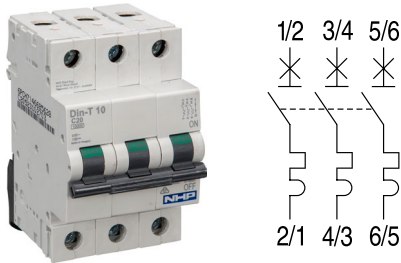

Width 54 mm

## 4 Pole

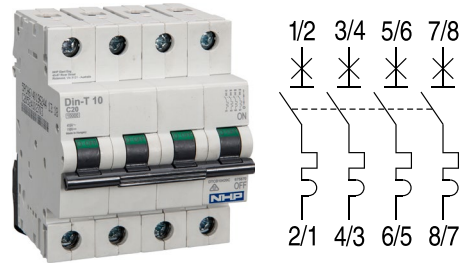

Width 72 mm

In (A)	B-Curve (3-5 In)	C-Curve (5-10 In)	D-Curve (10-20 In)
0.5	-	DTCB10305C	DTCB10305D
1	-	DTCB10301C	DTCB10301D
2	-	DTCB10302C	DTCB10302D
3	-	-	-
4	-	DTCB10304C	DTCB10304D
6	DTCB10306B	DTCB10306C	DTCB10306D
10	DTCB10310B	DTCB10310C	DTCB10310D
13	DTCB10313B	DTCB10313C	DTCB10313D
16	DTCB10316B	DTCB10316C	DTCB10316D
20	DTCB10320B	DTCB10320C	DTCB10320D
25	DTCB10325B	DTCB10325C	DTCB10325D
32	DTCB10332B	DTCB10332C	DTCB10332D
40	DTCB10340B	DTCB10340C	DTCB10340D
50	DTCB10350B	DTCB10350C	DTCB10350D
63	DTCB10363B	DTCB10363C	DTCB10363D

In (A)	B-Curve (3-5 In)	C-Curve (5-10 In)	D-Curve (10-20 In)
0.5	-	-	-
1	-	DTCB10401C	-
2	-	DTCB10402C	-
3	-	DTCB10403C	-
4	-	DTCB10404C	DTCB10404D
6	DTCB10406B	DTCB10406C	DTCB10406D
10	DTCB10410B	DTCB10410C	DTCB10410D
13	-	DTCB10413C	DTCB10413D
16	DTCB10416B	DTCB10416C	DTCB10416D
20	DTCB10420B	DTCB10420C	DTCB10420D
25	DTCB10425B	DTCB10425C	DTCB10425D
32	DTCB10432B	DTCB10432C	DTCB10432D
40	DTCB10440B	DTCB10440C	DTCB10440D
50	DTCB10450B	DTCB10450C	DTCB10450D
63	DTCB10463B	DTCB10463C	DTCB10463D

## Voltage Ratings

Nominal Voltage $U_n$	AC	1P	240, 415 V AC
		3P / 4P	415 V AC
	DC	1P	48 V DC
		2P (In Series)	110 V DC
Frequency	50 / 60 Hz		
	DC: 1.4 x mag. trip		
	400 Hz: 1.5 x mag. trip		
Maximum Service Voltage $U_{bmax}$	250 / 440 V AC		
	53 / 120 V DC		
Minimum Service Voltage $U_{bmin}$	12		
Selectivity Class (IEC 60898)	A		
Isolator Application	IEC 60947-2	Yes	
Rated Insulation Voltage	Pollution Degree 2	500 V	
	Pollution Degree 3	440 V	
Impulse Withstand Test Voltage	6 kV		
Insulation Resistance	10000 mOhm		
Dielectric Rigidity	2.5 kV		

## Environmental

Vibration Resistance (IEC 77 / 16.3) (in x, y, z direction)	3 g	
Endurance	Electrical at $U_n$ , In	10000 cycles
	Mechanical	20000 cycles
Utilisation Category (IEC 60947-2)	A	
Protection Degree	Outside	IP20
	Inside	IP40
Self-extinguish Degree (According to UL94)	UL 94 V-2	
Tropicalisation (IEC60068-2 / DIN 40046)	+55 °C / 95 % RH	
Operating Temperature	-25 °C / +55 °C	
Storage Temperature	-55 °C / +55 °C	

## Connection

Rigid Cable Min / Max (Top)	1 mm <sup>2</sup> / 35 mm <sup>2</sup>	
Flexible Cable Min / Max (Top)	0.75 mm <sup>2</sup> / 25 mm <sup>2</sup>	
Rigid Cable Min / Max (Bottom)	1 mm <sup>2</sup> / 35 mm <sup>2</sup>	
Flexible Cable Min / Max (Bottom)	0.75 mm <sup>2</sup> / 25 mm <sup>2</sup>	
Torque (Top / Bottom)	4.5 / 4.5 Nm	
Busbar	Connection Top	Pin
	Connection Bottom	Fork / Pin

## Physical

Dimensions (H x W x D)	1P	86 x 18 x 76 mm
	2P	86 x 36 x 76 mm
	3P	86 x 54 x 76 mm
	4P	86 x 72 x 76 mm
Weight	0.12 / 0.24 / 0.36 / 0.48 kg	
Package	12 module	



### Short-Circuit Capacity AC

IEC 60898	Icn	1P	230 / 400 V	10
		2P	230 / 400 V	10
		3P / 4P	230 / 400 V	10
Ics (Service)		% Icn		75
IEC 60947-2	Icu (Ultimate)	1P	127 V	30
			240 V	15
			415 V	4
		2P	127 V	40
			240 V	30
			415 V	15
	3P / 4P	240 V	30	
		415 V	15	
		440 V	10	
	Ics (Service)		% Icu	
NEMA AB1 (120 / 240 V)				30

### B-Curve Characteristics

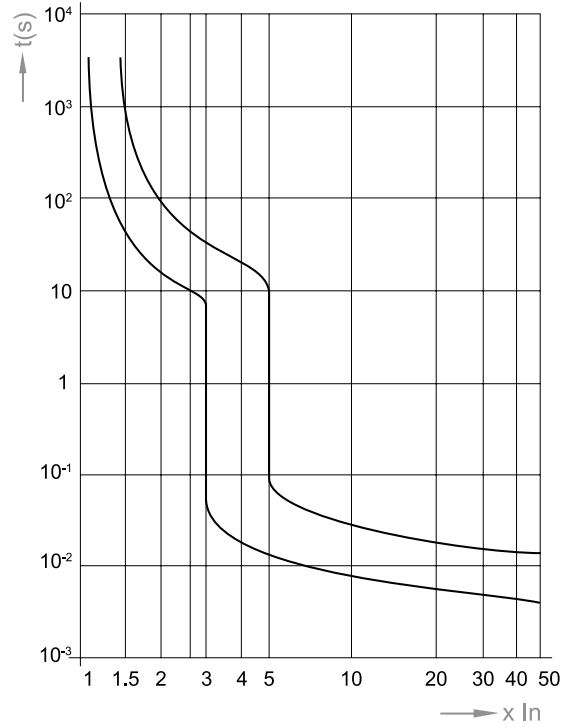

### Short-Circuit Capacity DC

IEC 60947-2	Icu (Ultimate)	1P	≤ 60 V	25
		2P	≤ 220 V	-
			≤ 125 V	30
		2P	≤ 440 V	-
	Ics (Service)		% Icu	100

### C-Curve Characteristics

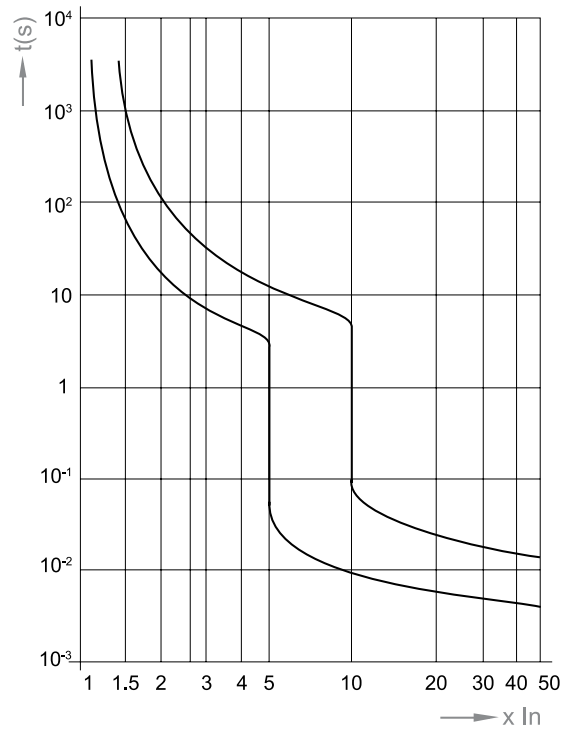



### D-Curve Characteristics

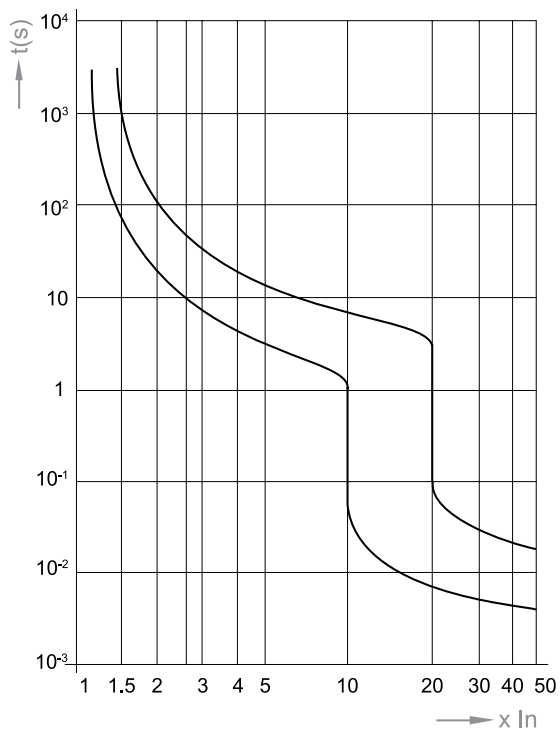

### Let-through Energy $I^2t$ (A<sup>2</sup>s) C-Curve

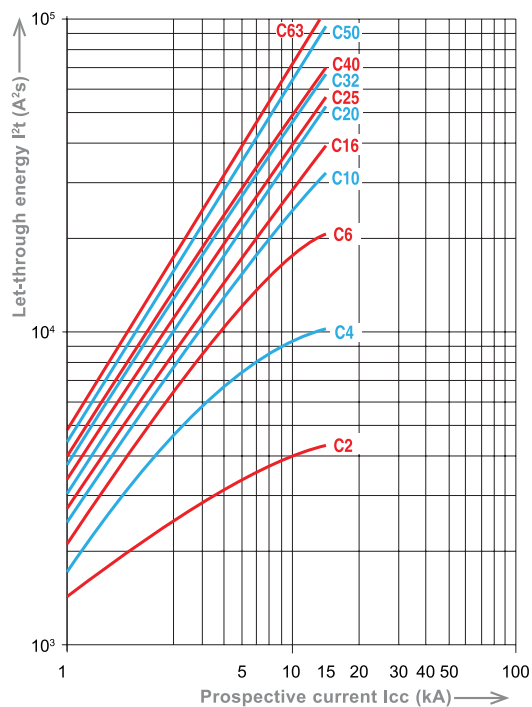

### Let-through Energy $I^2t$ (A<sup>2</sup>s) B-Curve

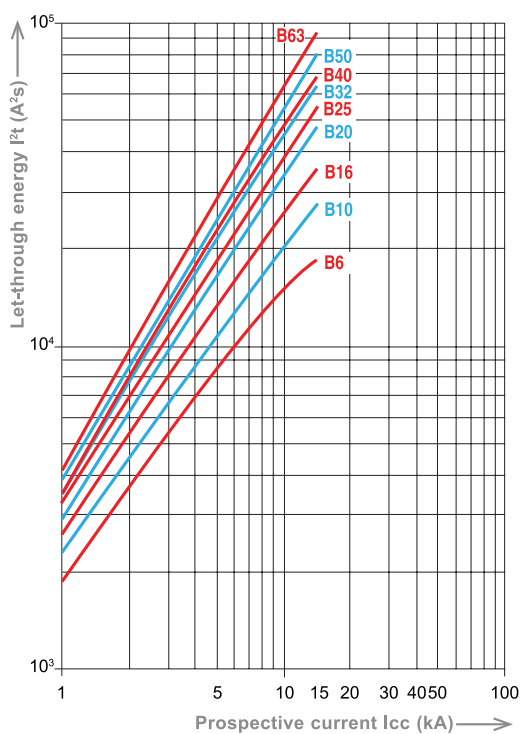

### Let-through Energy $I^2t$ (A<sup>2</sup>s) D-Curve

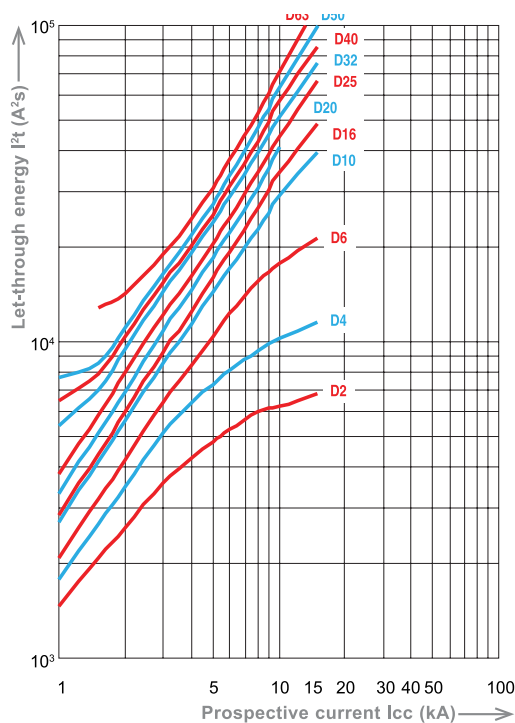

MCBs and RCBOs



### Limited Peak Current (kA) at 230 / 400 V B-Curve

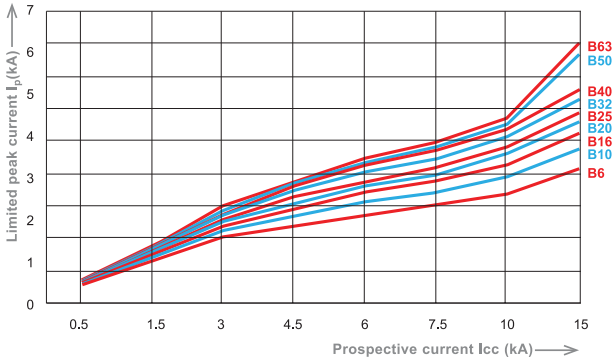

### Limited Peak Current (kA) at 230 / 400 V C-Curve

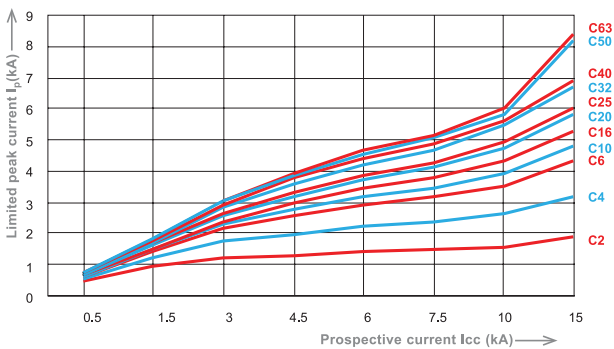

### Limited Peak Current (kA) at 230 / 400 V D-Curve

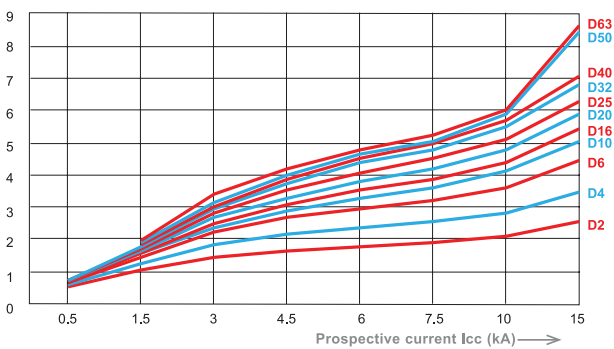

### Ambient Temperature Influence at 0.5 - 6 A

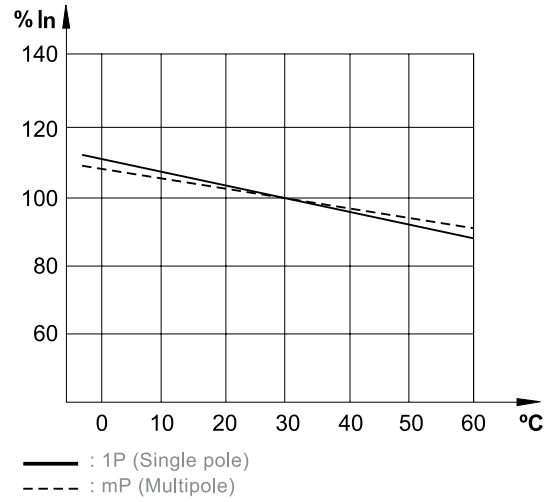

### Ambient Temperature Influence at 10 A

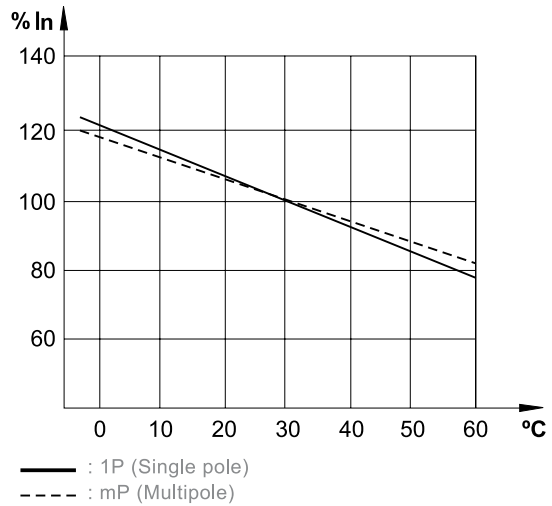

## Ambient Temperature Influence at 16-40 A

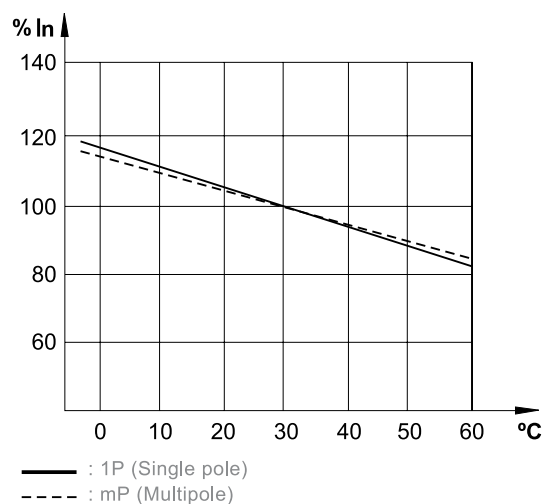

## Ambient Temperature Influence at 50-63 A

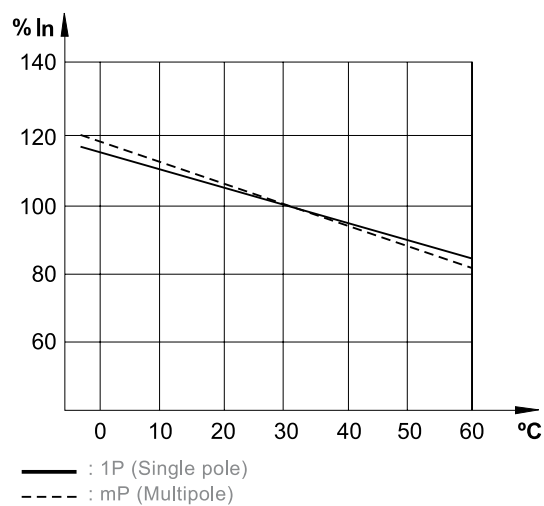

## Power Loss

In (A)	Voltage Drop (V)	Energy Loss Pw (W)	Resistance Z (mOhm)
0.5	2.23	1.12	4458.00
1	1.27	1.27	1272.00
2	0.62	1.24	310.00
3	0.52	1.56	173.00
4	0.37	1.49	93.00
6	0.26	1.57	43.60
8	0.16	1.24	19.40
10	0.16	1.56	15.60
13	0.16	2.01	11.90
16	0.16	2.57	10.10
20	0.14	2.76	6.90
25	0.13	3.19	5.10
32	0.10	3.07	3.00
40	0.10	4.00	2.50
50	0.09	4.50	1.80
63	0.08	5.16	1.30

# DTCB10H



- ✓ High speed and rapid arc quenching technology ensuring the highest level of protection is provided
- ✓ DIN rail mounting
- ✓ Free tripping mechanism even if toggle is locked ON or OFF
- ✓ AS/NZS 60947-2 & AS/NZS 60898\*
- ✓ Centre trip position & trip test button
- ✓ Red ON or Green OFF status flag
- ✓ Sealable for tamper proof operation
- ✓ Pad lock accessory restricts unauthorized action
- ✓ Large capacity terminals
- ✓ 2 arc chambers ensuring excellent operating/backup characteristics
- ✓ Fast connection NCH Hybrid busbar chassis
- ✓ For commercial and industrial applications
- ✓ Suits pole-covers, loadcentres and the Concept range of Panelboards

\* When not mounted on NCH chassis IP20 shroud must be fitted



## General

Tripping Characteristics	B, C, D
Nominal Current Rating At 40 °C	80 - 125
Poles	1P / 2P / 3P / 4P
Neutral Pole Protected	Yes

## Short Circuit

I <sub>cn</sub> 230 / 400 V 1P / 2P / 3P / 4P	15 / 15 / 15 / 15 kA
---	----------------------

## Voltage

Nominal Voltage U <sub>n</sub>	AC	1P	240, 415 V AC
		3P / 4P	415 V AC
Nominal Voltage U <sub>n</sub>	DC	1P	125 V DC
		2P (In Series)	250 V DC
		3P / 4P	375 / 500 V DC
Frequency	50 / 60 Hz		
Maximum Service Voltage U <sub>bmax</sub>	250 / 440 V AC 125 V DC per pole		
Minimum Service Voltage U <sub>bmin</sub>	12 V AC		

## Connections

Maximum Cable Size	Rigid / Flexible (Top)	50 mm <sup>2</sup> / 70 mm <sup>2</sup>
	Rigid / Flexible (Bottom)	50 mm <sup>2</sup> / 70 mm <sup>2</sup>



## Application



Commercial and industrial power applications when circuits exceed 63 A. Suitable for use in pole-covers, loadcentres and the Concept range of Panelboards with hybrid chassis.

## Dimensions

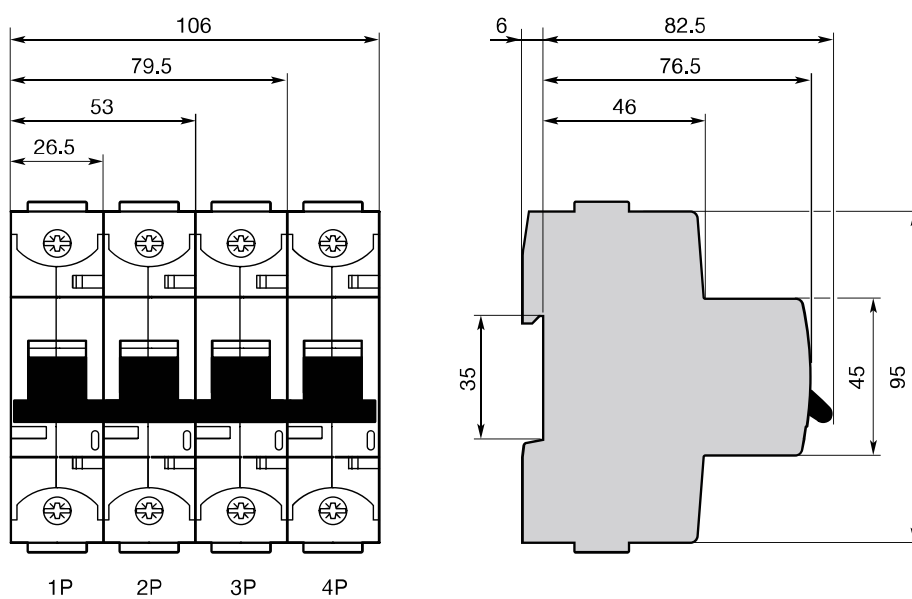



1 Pole

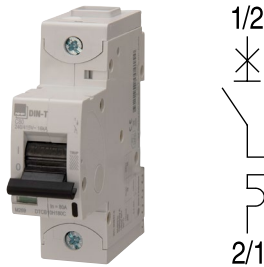

Width 27 mm

2 Pole

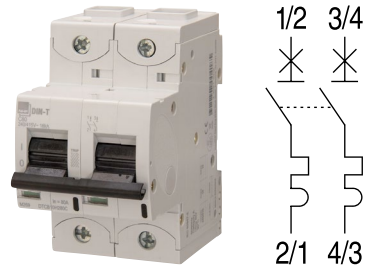

Width 53 mm

Amps (In)	B-Curve (3-5 In)	C-Curve (5-10 In)	D-Curve (10-20 In)
80	DTCB10H180B	DTCB10H180C	DTCB10H180D
100	DTCB10H1100B	DTCB10H1100C	DTCB10H1100D
125	DTCB10H1125B	DTCB10H1125C	DTCB10H1125D

Amps (In)	B-Curve (3-5 In)	C-Curve (5-10 In)	D-Curve (10-20 In)
80	DTCB10H280B	DTCB10H280C	DTCB10H280D
100	DTCB10H2100B	DTCB10H2100C	DTCB10H2100D
125	DTCB10H2125B	DTCB10H2125C	DTCB10H2125D

3 Pole

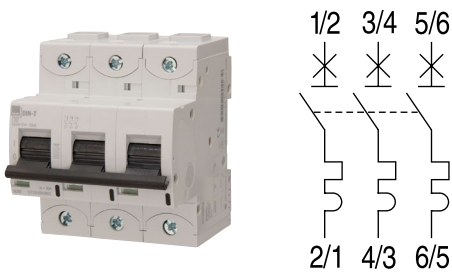

Width 80 mm

4 Pole

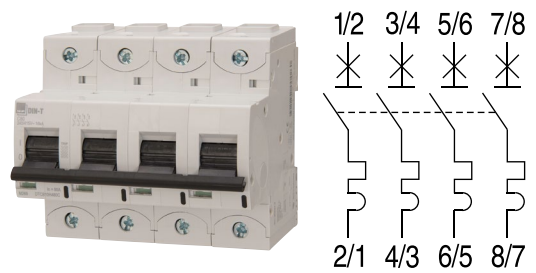

Width 106 mm

Amps (In)	B-Curve (3-5 In)	C-Curve (5-10 In)	D-Curve (10-20 In)
80	DTCB10H380B	DTCB10H380C	DTCB10H380D
100	DTCB10H3100B	DTCB10H3100C	DTCB10H3100D
125	DTCB10H3125B	DTCB10H3125C	DTCB10H3125D

Amps (In)	B-Curve (3-5 In)	C-Curve (5-10 In)	D-Curve (10-20 In)
80	DTCB10H480B	DTCB10H480C	DTCB10H480D
100	DTCB10H4100B	DTCB10H4100C	DTCB10H4100D
125	DTCB10H4125B	DTCB10H4125C	DTCB10H4125D

## Voltage Ratings

Nominal Voltage $U_n$	AC	1P	240, 415 V AC
		3P / 4P	415 V AC
	DC	1P	125 V DC
		2P (In Series)	250 V DC
3P		375 V DC	
4P		500 V DC	
Frequency	50 / 60 Hz		
	DC: 1.4 x mag. trip 400Hz: 1.5 x mag. trip		
Maximum Service Voltage $U_{bmax}$	250 / 440 V AC 125 V DC per pole		
Minimum Service Voltage $U_{bmin}$	12		
Selectivity Class (IEC 60898)	A		
Isolator Application	IEC 60947-2	Yes	
Rated Insulation Voltage	Pollution Degree 2	500 V	
	Pollution Degree 3	500 V	
Impulse Withstand Test Voltage	8 kV		
Insulation Resistance	10000 mOhm		
Dielectric Rigidity	2.5 kV		

## Environmental

Vibration Resistance acc. to IEC / EN 60068-2-6	2 - 13.2 Hz / 1 mm 13.2 - 100 Hz / 0.7 g	
Endurance	Electrical at $U_n$ , $I_n$	6000 (80 - 100 A) 4000 (125 A)
	Mechanical	10000 cycles
Utilisation Category (IEC 60947-2)	A	
Protection Degree	Outside	IP20
	Inside	IP40
Self-extinguish Degree (According to UL94)	-	
Tropicalisation (IEC60068-2 / DIN 40046)	+55 °C / 95% RH	
Operating Temperature	-25 °C / +60 °C	
Storage Temperature	-40 °C / +70 °C	

## Connection

Rigid Cable Min / Max (Top)	50 mm <sup>2</sup> / 50 mm <sup>2</sup>	
Flexible Cable Min / Max (Top)	70 mm <sup>2</sup> / 70 mm <sup>2</sup>	
Rigid Cable Min / Max (Bottom)	6 mm <sup>2</sup> / 50 mm <sup>2</sup>	
Flexible Cable Min / Max (Bottom)	6 mm <sup>2</sup> / 70 mm <sup>2</sup>	
Torque (Top / Bottom)	3 / 4 Nm	
Busbar	Connection Top	-
	Connection Bottom	-

## Physical

Dimensions (H x W x D)	1P	100 x 27 x 90 mm
	2P	100 x 53 x 90 mm
	3P	100 x 80 x 90 mm
	4P	100 x 106 x 90 mm
Weight	0.25 / 0.49 / 0.74 / 0.98 kg	
Package	1 module	

## Short-Circuit Capacity AC

IEC 60898	$I_{cn}$	1P	230 / 400 V	15 kA
		2P	230 / 400 V	15 kA
		3P / 4P	230 / 400 V	15 kA
	$I_{cs}$ (Service)	% $I_{cn}$	50	
IEC 60947-2	$I_{cu}$ (Ultimate)	1P	127 V	-
			240 V	16 kA
		2P	415 V	16 kA
			127 V	-
		3P / 4P	240 V	16 kA
			415 V	16 kA
	$I_{cs}$ (Service)	240 V	16 kA	
		440 V	15 kA	
		NEMA AB1 (120 / 240 V)	-	



## Short-Circuit Capacity DC

IEC 60947-2	I <sub>cu</sub> (Ultimate)	1P 125V	10 kA
		2P 250V	10 kA
		3P 375V	10 kA
		4P 500V	10 kA
	I <sub>cs</sub> (Service)	% I <sub>cu</sub>	100

## Power Loss

I <sub>n</sub> (A)	Voltage Drop (V)	Energy Loss P <sub>w</sub> (W)	Resistance Z (mOhm)
80	0.08	6.00	0.90
100	0.08	7.50	0.75
125	0.08	9.50	0.60

## B-Curve Characteristics

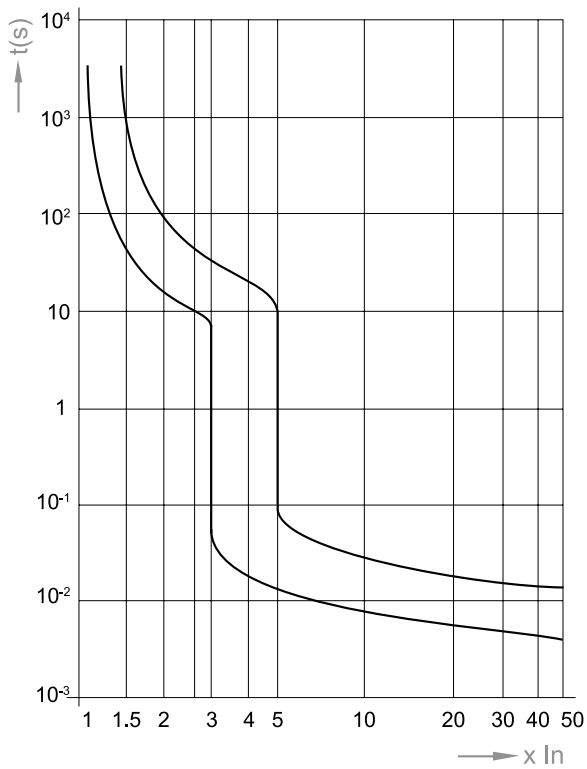

## C-Curve Characteristics

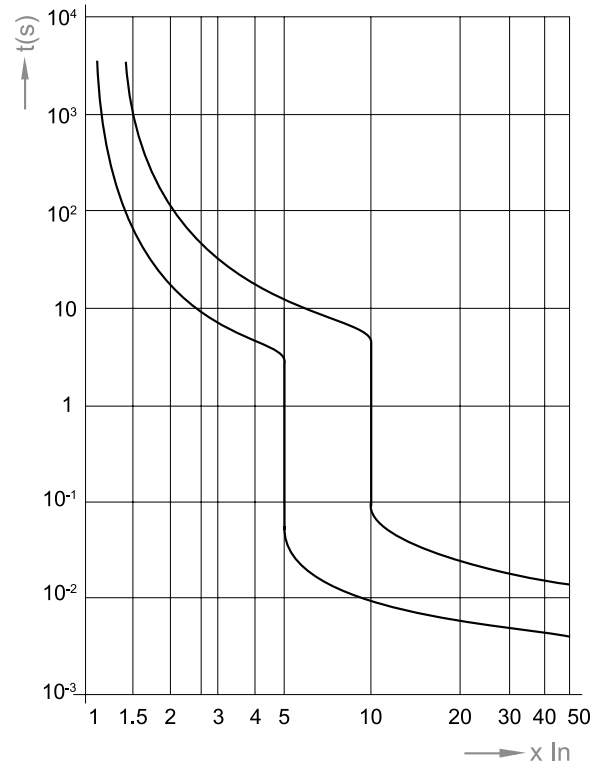

## D-Curve Characteristics

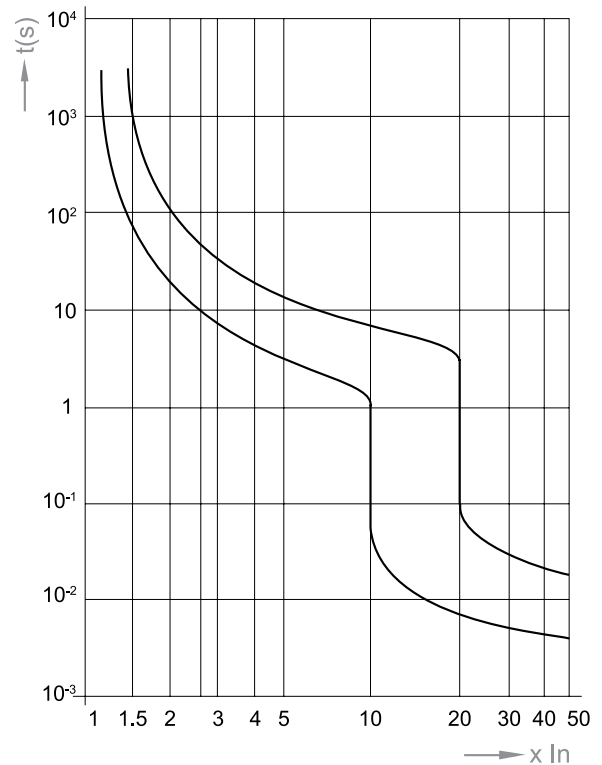

## 230/400V Let-through energy

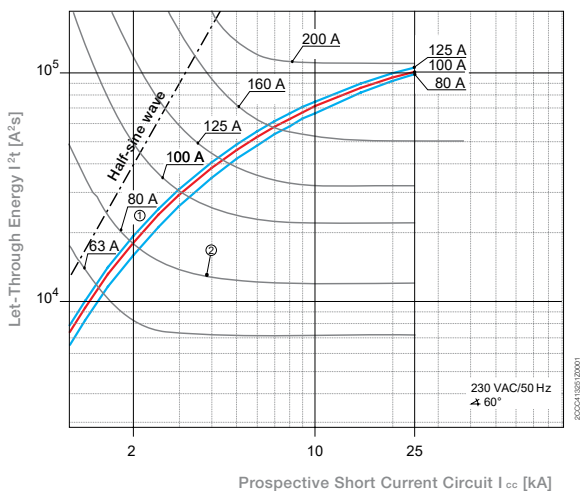

## 230/400V Let-through current

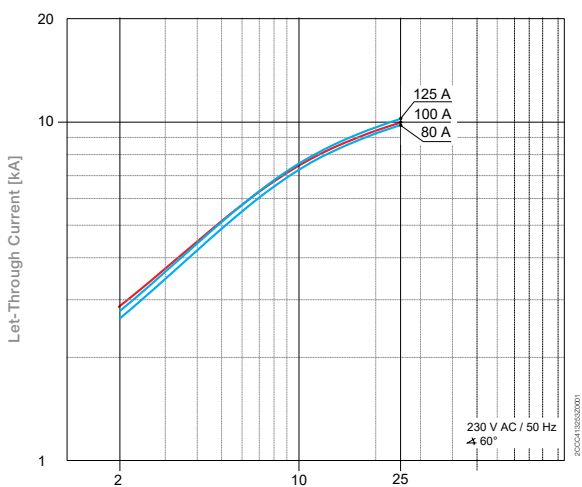

# DIN-T15



- ✓ High speed and rapid arc quenching technology ensuring the highest level of protection is provided
- ✓ DIN rail mounting
- ✓ Free tripping mechanism even if toggle is locked ON or OFF
- ✓ Complies with AS/NZS 60947-2
- ✓ DIN-T15 MCBs feature 15 kA+ short circuit rating
- ✓ C curve for general light, power and motor starting applications
- ✓ Pad lockable and sealable toggle restricts unauthorized action
- ✓ Large capacity terminals
- ✓  $I_{CS} = 50\% I_{CU}$
- ✓ Fast connection pin busbar comb or NC or GB busbar chassis
- ✓ For industrial applications
- ✓ Suits pole-covers, loadcentres and the Concept range of Panelboards



## General

Tripping Characteristics	C
Nominal Current Rating At 30 °C	6 - 63 A
Poles	1P / 2P / 3P / 4P
Neutral Pole Protected	Yes

## Short Circuit

$I_{cn}$ 230 / 400 V 1P / 2P / 3P / 4P	15 / 15 / 15 / 15 kA
--	----------------------

## Voltage

Nominal Voltage $U_n$	AC	1P	240, 415 V AC
		3P / 4P	415 V AC
	DC	1P	48 V DC
		2P (In Series)	110 V DC

Frequency	50 / 60 Hz
-----------	------------

Maximum Service Voltage $U_{bmax}$	250 / 440 V AC 53 / 120 V DC
------------------------------------	---------------------------------

Minimum Service Voltage $U_{bmin}$	12 V AC
------------------------------------	---------

## Connections

Maximum Cable Size	Rigid / Flexible (Top)	35 mm <sup>2</sup> / 25 mm <sup>2</sup>
	Rigid / Flexible (Bottom)	35 mm <sup>2</sup> / 25 mm <sup>2</sup>

## Application

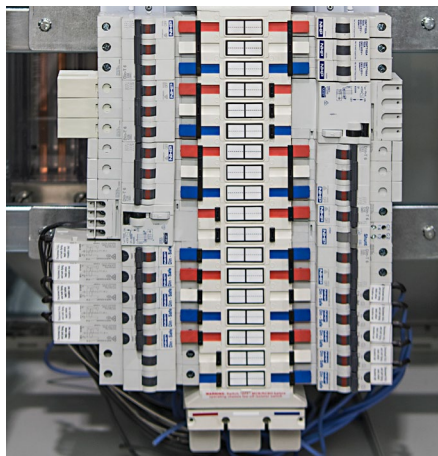

Industrial and mining light and power applications. Suitable for use in pole-covers, loadcentres utilising fork or pin busbar comb and the Concept range of Panelboards using busbar chassis.

## Dimensions

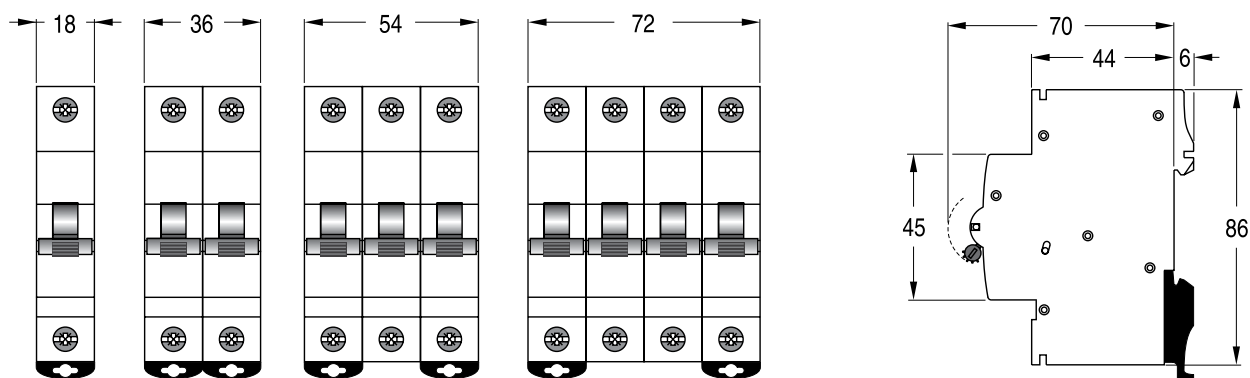



1 Pole

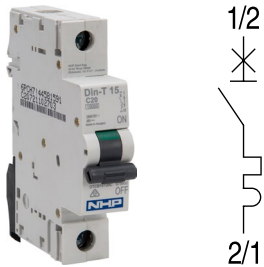

Width 18 mm

2 Pole

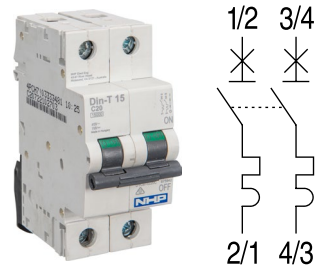

Width 36 mm

Amps (In)	C-Curve (5-10 In)
6	DTCB15106C
10	DTCB15110C
13	DTCB15113C
16	DTCB15116C
20	DTCB15120C
25	DTCB15125C
32	DTCB15132C
40	DTCB15140C
50	DTCB15150C
63	DTCB15163C

Amps (In)	C-Curve (5-10 In)
6	DTCB15206C
10	DTCB15210C
13	DTCB15213C
16	DTCB15216C
20	DTCB15220C
25	DTCB15225C
32	DTCB15232C
40	DTCB15240C
50	DTCB15250C
63	DTCB15263C



## 3 Pole

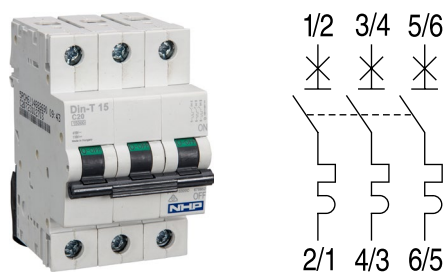

Width 54 mm

## 4 Pole

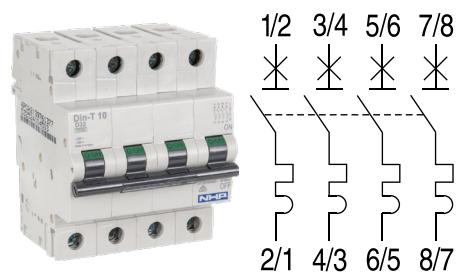

Width 72 mm

Amps (In)

C-Curve (5-10 In)

6	DTCB15306C
10	DTCB15310C
13	DTCB15313C
16	DTCB15316C
20	DTCB15320C
25	DTCB15325C
32	DTCB15332C
40	DTCB15340C
50	DTCB15350C
63	DTCB15363C

Amps (In)

C-Curve (5-10 In)

6	DTCB15406C
10	DTCB15410C
13	DTCB15413C
16	DTCB15416C
20	DTCB15420C
25	DTCB15425C
32	DTCB15432C
40	DTCB15440C
50	DTCB15450C
63	DTCB15463C

## Voltage Ratings

Nominal Voltage Un	AC	1P	240, 415 V AC
		3P / 4P	415 V AC
	DC	1P	48 V DC
		2P (In Series)	110 V DC
Frequency	50 / 60 Hz		
	DC: 1.4 x mag. trip		
	400 Hz: 1.5 x mag. trip		
Maximum Service Voltage Ubmax		250 / 440 V AC 53 / 120 V DC	
Minimum Service Voltage Ubmin		12	
Selectivity Class (IEC 60898)		A	
Isolator Application	IEC 60947-2	Yes	
Rated Insulation Voltage	Pollution Degree 2	500 V	
	Pollution Degree 3	440 V	
Impulse Withstand Test Voltage		6 kV	
Insulation Resistance		10000 mOhm	
Dielectric Rigidity		2.5 kV	

## Environmental

Vibration Resistance (IEC 77 / 16.3) (in x, y, z direction)		3 g
Endurance	Electrical at Un, In	4000 cycles
	Mechanical	20000 cycles
Utilisation Category (IEC 60947-2)		A
Protection Degree	Outside	IP20
	Inside	IP40
Self-extinguish Degree (According to UL94)		UL 94 V-2
Tropicalisation (IEC60068-2 / DIN 40046)		+55 °C / 95 % RH
Operating Temperature		-25 °C / +55 °C
Storage Temperature		-55 °C / +55 °C

## Connection

Rigid Cable Min / Max (Top)		1 mm <sup>2</sup> / 35 mm <sup>2</sup>
Flexible Cable Min / Max (Top)		0.75 mm <sup>2</sup> / 25 mm <sup>2</sup>
Rigid Cable Min / Max (Bottom)		1 mm <sup>2</sup> / 35 mm <sup>2</sup>
Flexible Cable Min / Max (Bottom)		0.75 mm <sup>2</sup> / 25 mm <sup>2</sup>
Torque (Top / Bottom)		4.5 / 4.5 Nm
Busbar	Connection Top	Pin
	Connection Bottom	Fork / Pin

## Physical

Dimensions (H x W x D)	1P	86 x 18 x 76 mm
	2P	86 x 36 x 76 mm
	3P	86 x 54 x 76 mm
	4P	86 x 72 x 76 mm
Weight		0.12 / 0.24 / 0.36 / 0.48 kg
Package		12 module



## Short-Circuit Capacity AC

IEC 60898	I <sub>cn</sub>	1P	230 / 400 V	-
		2P	230 / 400 V	-
		3P / 4P	230 / 400 V	-
I <sub>cs (Service)</sub>		% I <sub>cn</sub>	50	
IEC 60947-2	I <sub>cu*</sub> (Ultimate)	1P	127 V	50
			240 V	25 / 20 / 15
			415 V	-
		2P	127 V	-
			240 V	50 / 40 / 30
			415 V	25 / 20 / 15
	3P / 4P	240 V	50 / 40 / 30	
		415 V	25 / 20 / 15	
		440 V	20 / 15 / 10	
		I <sub>cs (Service)</sub>	% I <sub>cu</sub>	75
NEMA AB1 (120 / 240 V)		-		

\* 6-25 A / 32-40 A / 50-63 A

## Short-Circuit Capacity DC

IEC 60947-2	I <sub>cu</sub> (Ultimate)	1P	≤ 60 V	25
			≤ 220 V	-
		2P	≤ 125 V	30
			≤ 440 V	-
I <sub>cs (Service)</sub>		% I <sub>cu</sub>	100	

## C-Curve Characteristics

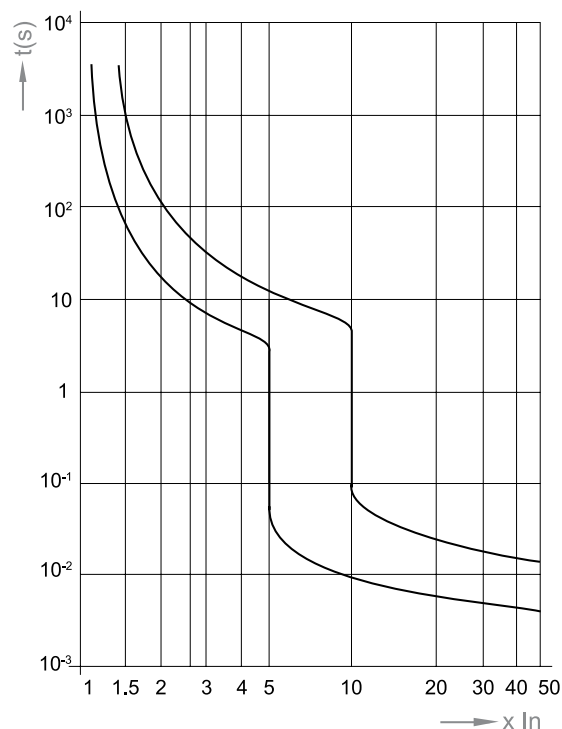

## Let-through energy I<sup>2</sup> t (A<sup>2</sup> s) C-Curve

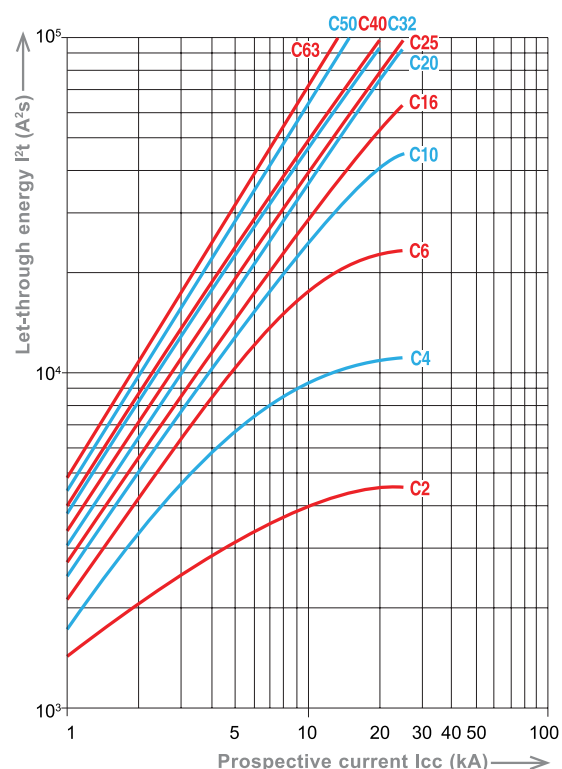

## Limited peak current (kA) at 230 / 400 V C-Curve

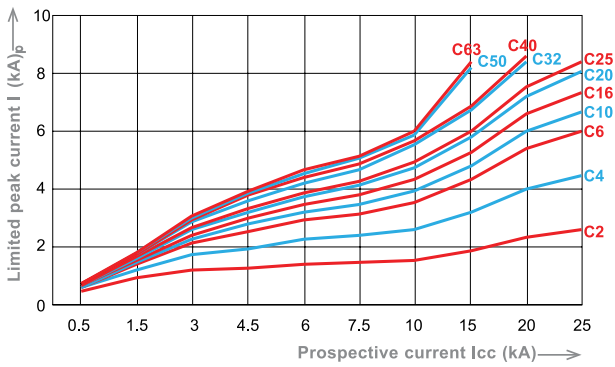

## Power Loss

$I_n$ (A)	Voltage Drop (V)	Energy Loss $P_w$ (W)	Resistance $Z$ (mOhm)
0.5	2.23	1.12	4458.00
1	1.27	1.27	1272.00
2	0.62	1.24	310.00
3	0.52	1.56	173.00
4	0.37	1.49	93.00
6	0.26	1.57	43.60
8	0.16	1.24	19.40
10	0.16	1.56	15.60
13	0.16	2.01	11.90
16	0.16	2.57	10.10
20	0.14	2.76	6.90
25	0.13	3.19	5.10
32	0.10	3.07	3.00
40	0.10	4.00	2.50
50	0.09	4.50	1.80
63	0.08	5.16	1.30

## General Accessories

### Pole Filler, Lock Dogs and Terminals

Lock Dog to securely lock off devices. Pole filler to cover unused spaces in loadcentres and Panelboards. Terminal pins to allow connection of larger cables or multiple cables to a terminal.



#### Item Description

#### Catalogue No.

Terminal 3 X 16 mm neutral link to suit RCCB

DTTAX16PN3

## Pin Type Busbar Combs

### IBC Type - 1-Phase (Comes Complete with End Caps)

Suitable for linking regular 18 mm pitch terminals, DIN-T Main Switches, MCBs and RCBOs in a loadcenter or in a control centre. Pin type busbar comb utilises the devices main tunnel terminal.

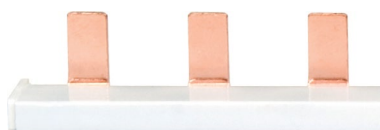

#### Item Description

#### Catalogue No.

Busbar Comb, 8 way, 100 A, 1P, Pin type with end caps

IBC108P

Busbar Comb, 12 way, 100 A, 1P, Pin type with end caps

IBC112P

Busbar Comb, 15 way, 100 A, 1P, Pin type with end caps

IBC115P

Busbar Comb, 18 way, 100 A, 1P, Pin type with end caps

IBC118P

Busbar Comb, 21 way, 100 A, 1P pin type with end caps

IBC121P

Busbar Comb, 55 way, 100 A, 1P pin type with end caps

IBC155P

## ICL Type - 2P, 3P and 3P+N

Suitable for linking regular 18 mm pitch terminals, DIN-T Main Switches, MCBs and RCBOs in a loadcenter or in a control centre. Pin type busbar comb utilises the devices main tunnel terminal.

Close up of pins

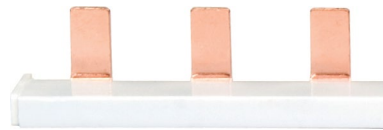
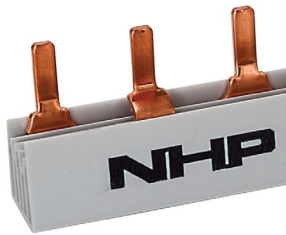

Item Description	Catalogue No.
Busbar Comb, 10 way, 80 A / 130 A, 1P+N, Pin type	ICL102
Busbar Comb, 56 way, 80 A / 130 A, 1P+N, Pin type	ICL562
Busbar Comb 6 way, 80 A / 130 A, 1P+N, Pin type	ICL62

Item Description	Catalogue No.
Busbar Comb, 12 way, 80 A / 130 A, 3P, Pin type	ICL123
Busbar Comb, 15 way, 80 A / 130 A, 3P, Pin type	ICL153
Busbar Comb, 18 way, 80 A / 130 A, 3P, Pin type	ICL183
Busbar Comb, 21 way, 80 A / 130 A, 3P, Pin type	ICL213
Busbar Comb, 57 way, 80 A / 130 A, 3P, Pin type	ICL573



Item Description	Catalogue No.
Busbar Comb 56 way, 80 A / 130 A, 3P+AUX, Pin type	ICL563A
Busbar Comb 56 way, 80 A / 130 A, 3P+N, Pin type	ICL564

## IBD Type - 3P

Suitable for linking 9 mm pitch terminals, 2-in-1 MCBs and RCBOs in a loadcenter or in a control centre. Pin type busbar comb utilises the devices main tunnel terminal.



Item Description	Catalogue No.
Busbar Comb 12 way, 80 A / 100 A, 3P, suits DTCBD	IBD312P
Busbar Comb 55 way, 80 A / 100 A, 3P, suits DTCBD	IBD355P
Busbar Comb 55 way, 80 A / 100 A, 3P+N, Pin type, suits 2P M6RCBD and DTCBD	IBD4552P
Busbar Comb 55 way, 80 A / 100 A, 3P+N, Pin type, suits DTCBD64	IBD4554P

## Busbar Comb End caps

### IBC and IBD Busbar End Caps

End caps to cover the end of cut busbar comb.



Item Description	Catalogue No.
Buscomb End Cap to suit 2P and 3P IBD	ICLEC23
Buscomb End Cap to suit 3P+N ICL	ICLEC4

## Busbar Comb Tee-off cap

Barrier / cover to bare tee-offs on busbar comb.



### Item Description

### Catalogue No.

Buscomb Tee-Off Caps Yellow (Strip of 5)

ICLTOC

## Terminal Connectors

Allows connection of cable to terminal, either larger cable or changes direction for cable termination.



### Item Description

### Catalogue No.

Buscomb Terminal Feeder 35 mm

DTCF35

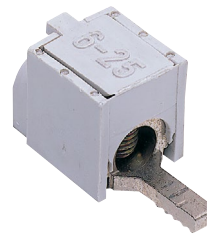

### Item Description

### Catalogue No.

Terminal Axial Pin 25 mm<sup>2</sup> (Insulated) to suit DIN MCBs

DTTAX25PN



**Item Description**

Terminal Axial Spade 25 mm (insulated) to suit DIN MCBs

**Catalogue No.**

DTTAX25SP

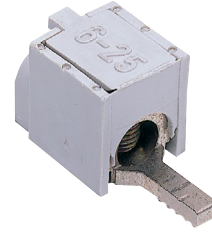
**Item Description**

Terminal Axial Pin 50 mm (insulated) to suit DIN MCBs

**Catalogue No.**

DTTAX50PN

**Item Description**

Terminal Long Lateral Pin 35 mm to suit DIN MCBs

**Catalogue No.**

DTTTL35LPN

**Item Description**

Terminal Lateral Pin 35 mm to suit DIN MCBs

**Catalogue No.**

DTTTL35PN

**Item Description**

Terminal Lateral Spade 35 mm to suit DIN MCBs

**Catalogue No.**

DTTTL35SP



## Terminal Covers and Pole Fillers

Barrier / cover to MCBs, RCBOs or fills void/cut-out in an escutcheon.

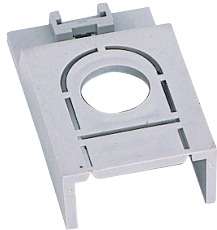

Item Description	Catalogue No.
Terminal Cover suits DIN-T10H	DINT10HTC



Item Description	Catalogue No.
Terminal Cover 35 mm suits DSRCBH	DSRCBHTC



Item Description	Catalogue No.
DIN Dummy MCB (Filler for touch protection)	DTLDM

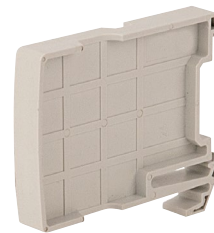

Item Description	Catalogue No.
DIN Spacer 1 / 2 Module 9 mm width	DTSP



Item Description	Catalogue No.
Terminal Cover 35 mm suits DIN-T MCBs	DTTC35



Item Description	Catalogue No.
Terminal Cover 5 mm suits DIN-T MCBs	DTTC5

## Other Lock Dogs (Non-Captive and Captive)

Allows for MCBs, RCBOs to be locked off by means of customer supplied padlock.



Item Description	Catalogue No.
DIN-T Metal Lock Dog Captive 6.5 mm	DCLD6



Item Description	Catalogue No.
DIN-T10H Lock Dog, Non-Captive suits hasp up to 7.0 mm.	DTLDH



Item Description	Catalogue No.
DIN Lock Dog, Non-Captive suits hasp up to 8.0 mm.	DTLD



## LOCKDIN

### Locking Devices

Captive locking system for MCBs, RCBOs to be securely locked off by means of customer supplied padlock up to 7.0 mm.

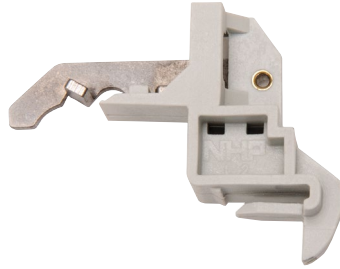

Item Description	Catalogue No.
LOCKDIN Left Hand Locking Assembly for MCBs and DSRCBH	DTLLA
LOCKDIN Right Hand Locking Assembly for MCBs and DSRCBH	DTLLARH
LOCKDIN Left Hand Locking Assembly for 2 Pole RCBOs	DTLLAB
LOCKDIN Right Hand Locking Assembly for 2 Pole RCBOs	DTLLABRH
LOCKDIN Right Hand / Left Hand Locking Assembly for DIN-T 10H	DTLLA10H
LOCKDIN Left Hand Locking Assembly for MCBs and DSRCBH (12 Pack)	DTLLABULK
LOCKDIN Right Hand Locking Assembly for MCBs and DSRCBH (12 Pack)	DTLLARHBULK

## Pole Fillers and Blanking Devices

Captive locking system for MCBs, RCBOs to be securely locked off by means of customer supplied padlock.

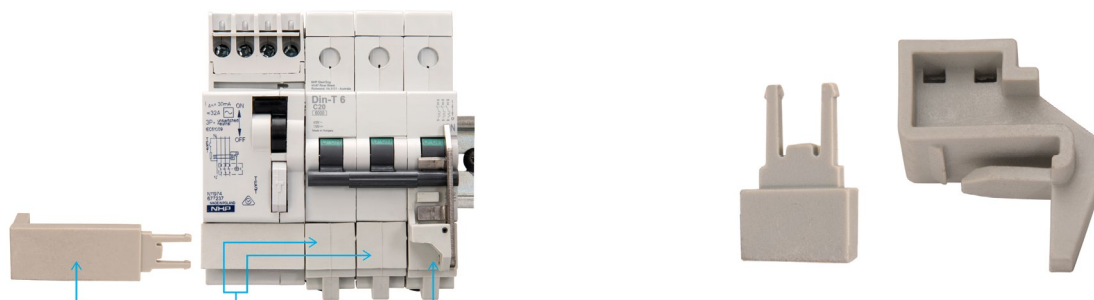

Item Description	Catalogue No.
LOCKDIN Locking Blank for DSRCM (Add On RCCB), 3 Pole MCBs	DTLCM

Item Description	Catalogue No.
LOCKDIN Locking Blank for MCBs and DSRCBH (12 Pack)	DTLLB



Item Description	Catalogue No.
LOCKDIN Pole Filler Extended Length to suit 63 mm Cutout (12 Pack)	DTLPPF



## Additional Accessories

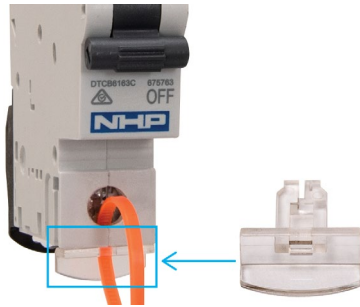

Item Description	Catalogue No.
DIN-T Sealing Plate 4 Pack to suit DIN-T MCBs	DTCBSEALPLATE

Item Description	Catalogue No.
DIN-T Panel Board Switch 1P. Trips connected MCB when escutcheon is opened.	DTPBS



Item Description	Catalogue No.
RESIN	LOCTITE480

# DIN-Safe RCBO Single Pole Width 10kA (DSRCBH)



- ✓ High speed and rapid arc quenching technology ensuring the highest level of protection is provided
- ✓ DIN rail mounting
- ✓ Free tripping mechanism even if toggle is locked or sealed ON or OFF
- ✓ Complies with AS/NZS 61009 (RCBOs)
- ✓ DSRCBH RCBOs feature 10 kA short circuit rating
- ✓ C curve for general light, power and motor starting applications
- ✓ D trip curve for high Inrush, motorstarting and transformer applications
- ✓ Type A RCD
- ✓ 30 mA sensitivity general personnel protection applications
- ✓ 10 mA sensitivity option for higher risk applications
- ✓ 100 mA sensitivity option
- ✓ Single screw RCBO features a neutral pigtail saving cable and installation time
- ✓ Pad lockable and sealable toggle restricts unauthorized action
- ✓ Fast connection pin/fork busbar comb or NC or GB busbar chassis
- ✓ Suits metal loadcentres and the Concept range of Panelboards
- ✓ Approval No. N17482 or RCM
- ✓ 10 mA units compliant with Type 1 requirements

## General

Tripping Characteristics	C, D
Sensitivity $I\Delta n$	10, 30, 100 mA
RCD Type	A
Nominal Current Rating at 30 °C	6 - 40 A
Poles	1P + N
Switched Neutral	No

## Short Circuit

Icn 230 1P	10000
$I\Delta m$	10

## Voltage

Frequency	50 / 60 Hz
Maximum Service Voltage $U_{bmax}$	265 V AC
Minimum Service Voltage $U_{bmin}$	195

## Connections

Maximum Cable Size	Rigid / Flexible (Top)	25 mm <sup>2</sup> / 16 mm <sup>2</sup>
	Rigid / Flexible (Bottom)	35 mm <sup>2</sup> / 25 mm <sup>2</sup>





## Application

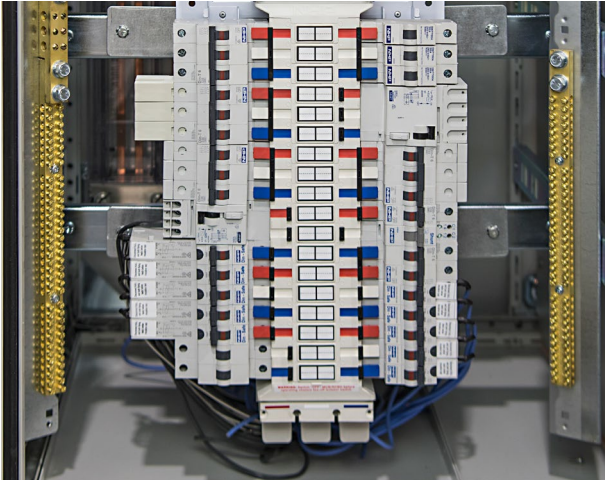

Commercial and industrial general light and power applications. Suitable for use in metal loadcentres and the Concept range of Panelboards.

## Connection

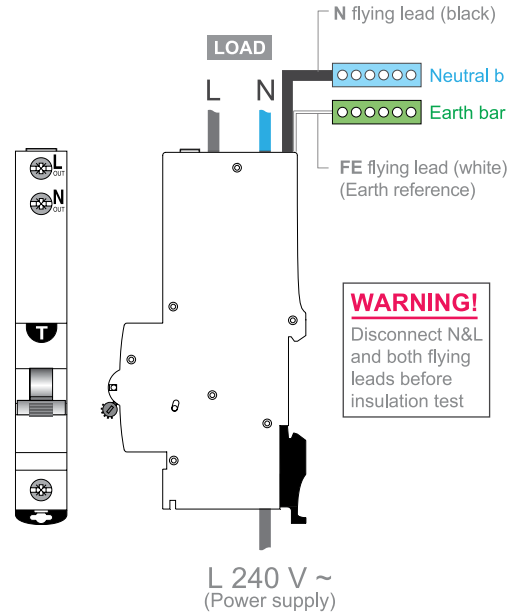

## Dimensions

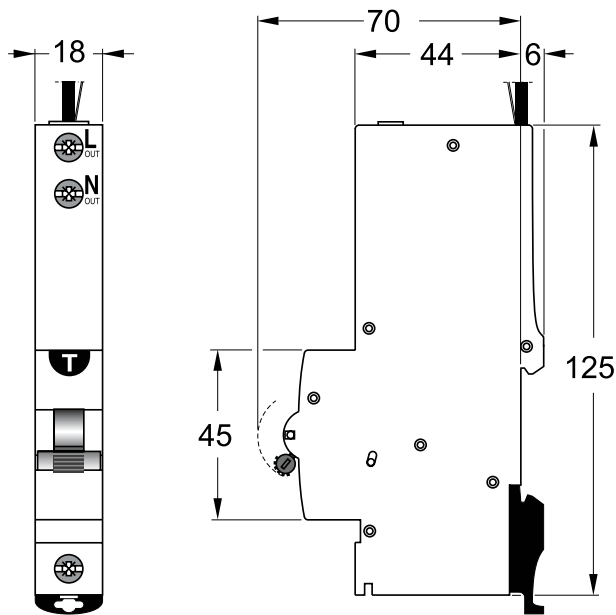



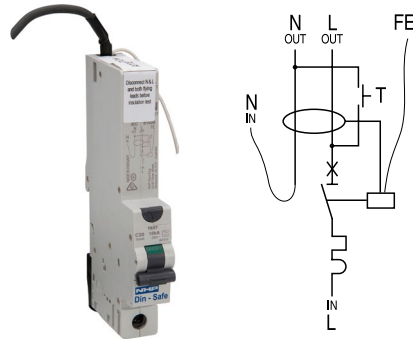

Sensitivity (mA)	Amps (In)	Width (mm)	C-Curve	D-Curve
<b>10 mA</b>	6	18	DSRCBH0610A	DSRCBH0610AD
	10	18	DSRCBH1010A	DSRCBH1010AD
	16	18	DSRCBH1610A	DSRCBH1610AD
	20	18	DSRCBH2010A	DSRCBH2010AD
	25	18	DSRCBH2510A	DSRCBH2510AD
	32	18	DSRCBH3210A	DSRCBH3210AD
	40	18	DSRCBH4010A	DSRCBH4010AD
	<b>30 mA</b>	6	18	DSRCBH0630A
10		18	DSRCBH1030A	DSRCBH1030AD
16		18	DSRCBH1630A	DSRCBH1630AD
20		18	DSRCBH2030A	DSRCBH2030AD
25		18	DSRCBH2530A	DSRCBH2530AD
32		18	DSRCBH3230A	DSRCBH3230AD
40		18	DSRCBH4030A	DSRCBH4030AD
<b>100 mA</b>		6	18	DSRCBH06100A
	10	18	DSRCBH10100A	DSRCBH10100AD
	16	18	DSRCBH16100A	DSRCBH16100AD
	20	18	DSRCBH20100A	DSRCBH20100AD
	25	18	DSRCBH25100A	DSRCBH25100AD
	32	18	DSRCBH32100A	DSRCBH32100AD
	40	18	DSRCBH40100A	DSRCBH40100AD

## Voltage Ratings

Sensitivity $I_{\Delta n}$	10, 30, 100 mA	
Tripping Time at $I_{\Delta n}$	< 40 ms	
RCD Type	A	
Nominal current rating at 30 °C	6 - 40 A	
Poles	1P + N	
Switched Neutral	No	
Frequency	50 / 60 Hz	
Power Supply	Bottom	
Maximum Service Voltage $U_{bmax}$	265 V AC	
Minimum Service Voltage $U_{bmin}$	195 V AC	
Isolator Application	IEC 60947-2	Yes
Rated Insulation Voltage	Pollution Degree 2	-
Impulse Withstand Test Voltage	6 kV	
Insulation Resistance	1000 mOhm	
Dielectric Rigidity	2500 V	

## Environmental

Vibration Resistance (IEC 77 / 16.3) (in x, y, z direction)	2 g	
Endurance	Electrical at $U_n, I_n$	10000 cycles
	Mechanical	20000 cycles
Utilisation Category (IEC 60947-2)	-	
Protection Degree	Outside	IP20
	Inside	IP40
Self-extinguish Degree (According to UL94)	UL 94 V-2	
Tropicalisation (IEC60068-2 / DIN 40046)	+55 °C / 95 % RH	
Operating Temperature	-5 °C / +55 °C	
Storage Temperature	-25 °C / +70 °C	

## Connection

Rigid Cable Min / Max (Top)	1 mm <sup>2</sup> / 25 mm <sup>2</sup>	
Flexible Cable Min / Max (Top)	1 mm <sup>2</sup> / 16 mm <sup>2</sup>	
Rigid Cable Min / Max (Bottom)	1 mm <sup>2</sup> / 35 mm <sup>2</sup>	
Flexible Cable Min / Max (Bottom)	1 mm <sup>2</sup> / 25 mm <sup>2</sup>	
Torque (Top / Bottom)	3 / 4.5 Nm	
Busbar	Connection Top	-
	Connection Bottom	Fork / Pin

## Physical

Dimensions (H x W x D)	1P + N	125 x 18 x 76 mm
Weight	0.35 kg	
Package	1 module	

## Short-Circuit Capacity

IEC 61009-1	Rated Making and Breaking Capacity ( $I_m$ )	400	A
	Residual Making and Breaking Capacity ( $I_{\Delta m}$ )	10000	A
	Conditional Short-Circuit Capacity ( $I_{nc}$ )	10	kA
	Conditional Residual Short-Circuit Capacity ( $I_{\Delta c}$ )	10	kA
	Rated Short-Circuit Capacity ( $I_{cn}$ )	10	kA



### C-Curve Characteristics

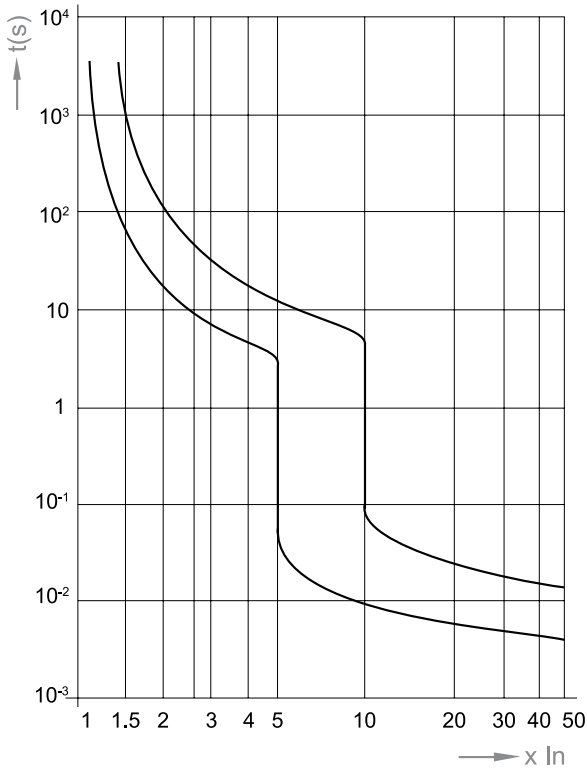

### Let-through Energy $I^2t$ (A<sup>2</sup> s) C-Curve

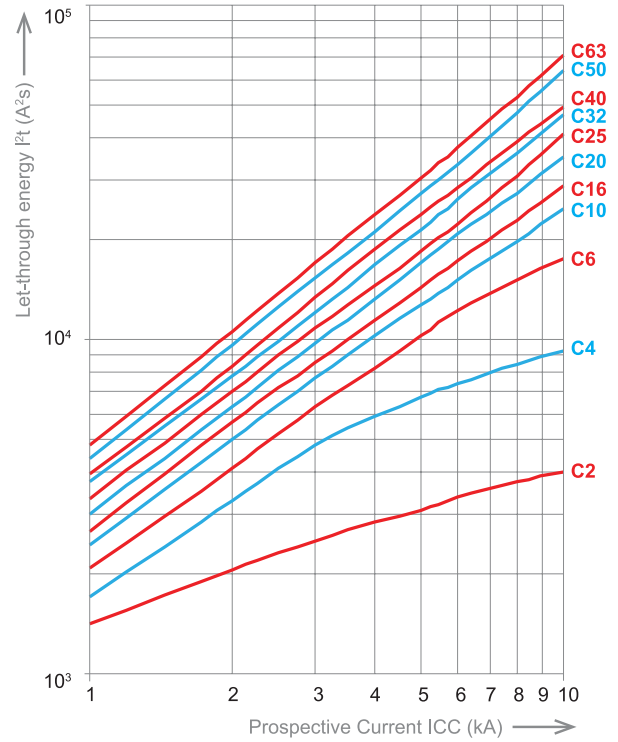

### D-Curve Characteristics

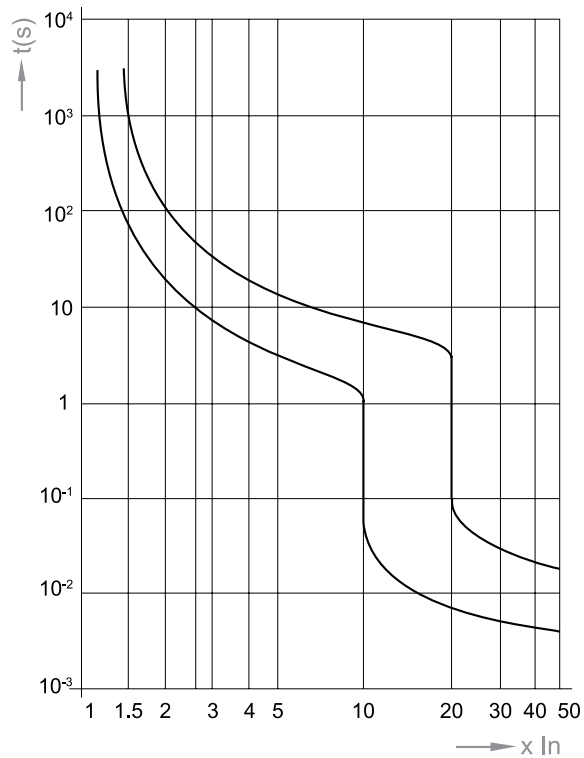

### Ambient Temperature Influence at 0.5-6 A

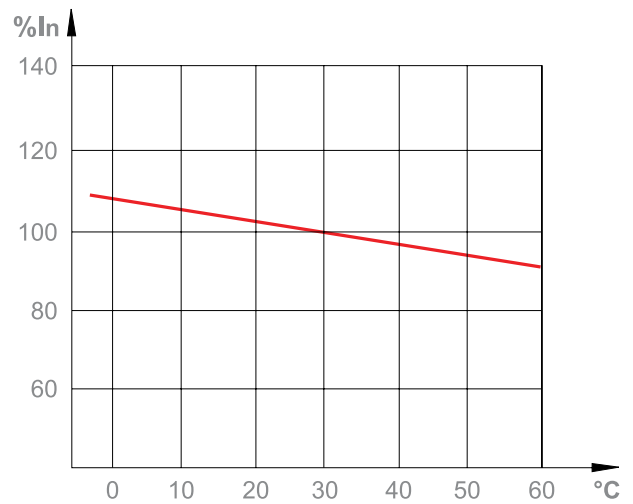



### Ambient Temperature Influence at 10 A

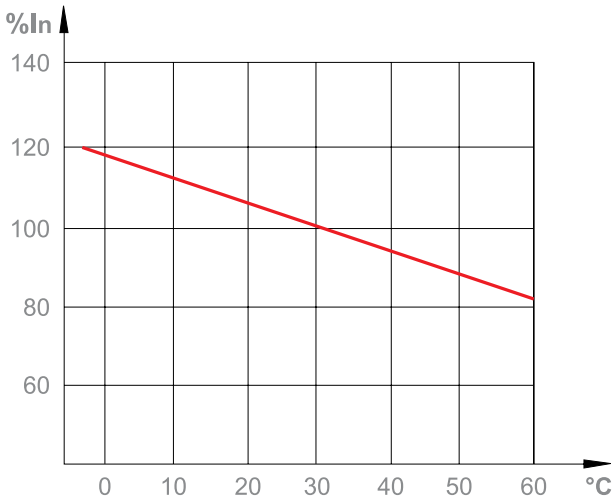

### Power Loss

In (A)	Voltage Drop (V)	Energy Loss Pw (W)	Resistance Z (mOhm)
6	0.26	43.6	1.57
8	0.16	19.4	1.242
10	0.16	15.6	1.56
13	0.155	11.9	2.011
16	0.162	10.1	2.566
20	0.136	6.9	2.76
25	0.128	5.1	3.188
32	0.096	3	3.188
40	0.1	2.5	4

### Ambient Temperature Influence at 16-40 A

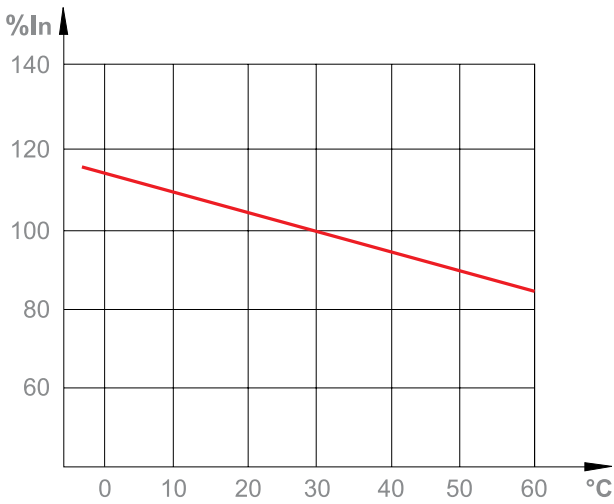

# DIN-Safe RCBO Compact Single Pole Width 6kA (DSRCBS)



- ✓ Complies with AS/NZS 61009 (RCBOs)
- ✓ DSRCBS RCBOs feature 6kA short circuit rating
- ✓ C curve for general light, power and motor starting applications
- ✓ Type A RCD with switched neutral
- ✓ 30 mA sensitivity general personnel protection applications
- ✓ 10 mA sensitivity option for higher risk applications
- ✓ Compact single screw RCBO features a neutral pigtail saving cable and installation time
- ✓ Pad lockable and sealable toggle restricts unauthorised action
- ✓ Fast connection pin/fork busbar comb or NC or GB busbar chassis
- ✓ Suits pole-covers, loadcentres and the Concept range of Panelboards
- ✓ Approval No. NSW24576 or RCM
- ✓ Energy Safe Victoria (ESV) compliant for residential applications
- ✓ 10 mA units compliant with Type 1 requirements



## General

Tripping Characteristics	C
Sensitivity I $\Delta$ n	10, 30 mA
RCD Type	A
Nominal Current Rating at 30 °C	6 - 32A
Poles	1P + N
Switched Neutral	Yes

## Short Circuit

Icn 230 1P	6000
I $\Delta$ m	6

## Voltage

Frequency	50 / 60 Hz
Maximum Service Voltage U <sub>bmax</sub>	255 V AC
Minimum Service Voltage U <sub>bmin</sub>	195

## Connections

Maximum Cable Size	Rigid / Flexible (Top)	25 mm <sup>2</sup> / 16 mm <sup>2</sup>
	Rigid / Flexible (Bottom)	35 mm <sup>2</sup> / 25 mm <sup>2</sup>



## Application

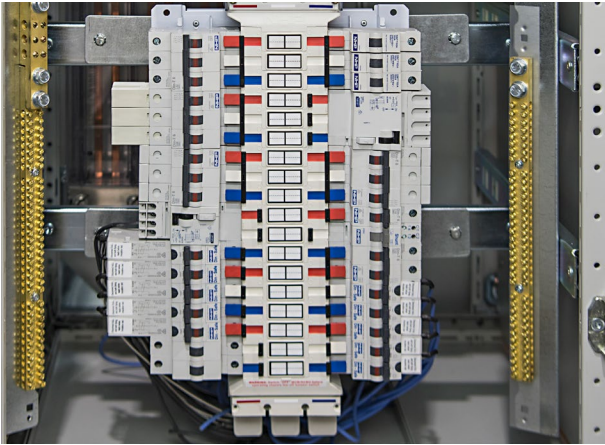

Light commercial and industrial general light and power applications. Suitable for use in loadcentres and the Concept range of Panelboards. Minimises impact into the wiring zone.

## Connection

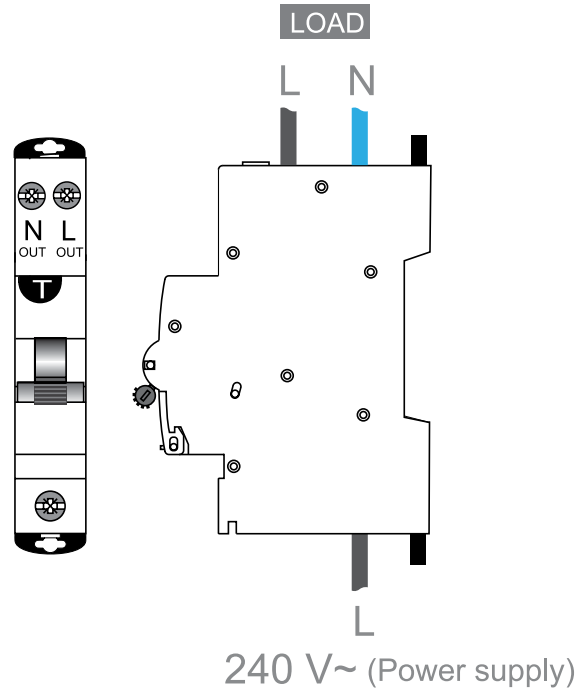

## Dimensions

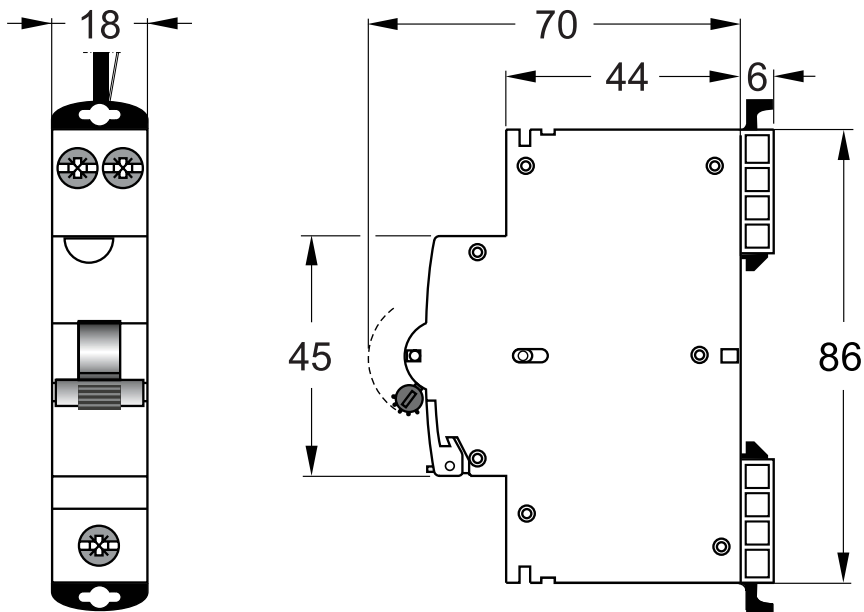

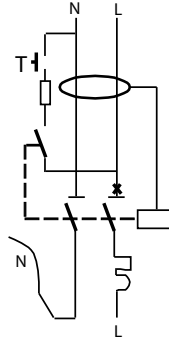

Sensitivity (mA)	Amp (In)	Width (mm)	C-Curve
<b>10 mA</b>	6	18	DSRCBS0610CAN
	10	18	DSRCBS1010CAN
	16	18	DSRCBS1610CAN
	20	18	DSRCBS2010CAN
	25	18	DSRCBS2510CAN
	32	18	DSRCBS3210CAN
<b>30 mA</b>	6	18	DSRCBS0630CAN
	10	18	DSRCBS1030CAN
	16	18	DSRCBS1630CAN
	20	18	DSRCBS2030CAN
	25	18	DSRCBS2530CAN
	32	18	DSRCBS3230CAN

## Voltage Ratings

Sensitivity $I_{\Delta n}$	10,30 mA	
Tripping Time at $I_{\Delta n}$	< 40 ms	
RCD Type	A	
Nominal current rating at 30 °C	6 - 32 A	
Poles	1P + N	
Switched Neutral	Yes	
Frequency	50 / 60 Hz	
Power Supply	Bottom	
Maximum Service Voltage $U_{bmax}$	255 V AC	
Minimum Service Voltage $U_{bmin}$	195 V AC	
Isolator Application	IEC 60947-2	Yes
Rated Insulation Voltage	Pollution Degree 2	-
Impulse Withstand Test Voltage	6 kV	
Insulation Resistance	1000 mOhm	
Dielectric Rigidity	2500 V	

## Environmental

Vibration Resistance (IEC 77 / 16.3) (in x, y, z direction)	2 g	
Endurance	Electrical at $U_n, I_n$	10000 cycles
	Mechanical	2000 cycles
Utilisation Category (IEC 60947-2)	-	
Protection Degree	Outside	IP20
	Inside	IP40
Self-extinguish Degree (According to UL94)	UL 94 V-2	
Tropicalisation (IEC60068-2 / DIN 40046)	+60 °C / 95 % RH	
Operating Temperature	-5 °C / +60 °C	
Storage Temperature	-25 °C / +70 °C	

## Connection

Rigid Cable Min / Max (Top)	1 mm <sup>2</sup> / 25 mm <sup>2</sup>	
Flexible Cable Min / Max (Top)	1.5 mm <sup>2</sup> / 16 mm <sup>2</sup>	
Rigid Cable Min / Max (Bottom)	1 mm <sup>2</sup> / 35 mm <sup>2</sup>	
Flexible Cable Min / Max (Bottom)	1.5 mm <sup>2</sup> / 25 mm <sup>2</sup>	
Torque (Top / Bottom)	3 / 4.5 Nm	
Busbar	Connection Top	-
	Connection Bottom	Fork/Pin

## Physical

Dimensions (H x W x D)	1P + N	86 x 18 x 76 mm
Weight	0.215 kg	
Package	1 module	

## Short-Circuit Capacity

IEC 61009-1	Rated Making and Breaking Capacity ( $I_m$ )	500	A
	Residual Making and Breaking Capacity ( $I_{\Delta m}$ )	6000	A
	Conditional Short-Circuit Capacity ( $I_{nc}$ )	6	kA
	Conditional Residual Short-Circuit Capacity ( $I_{\Delta c}$ )	6	kA
	Rated Short-Circuit Capacity ( $I_{cn}$ )	6	kA





### C-Curve Characteristics

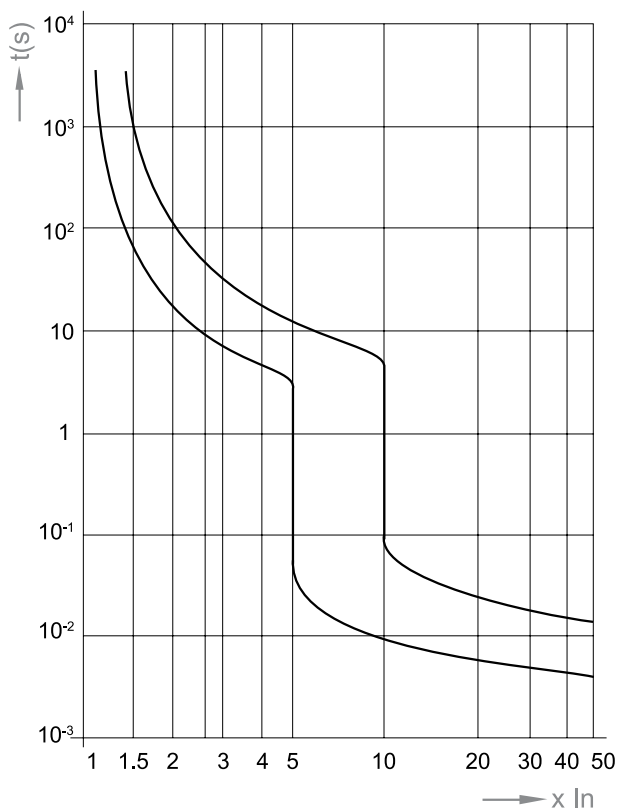

### Limited Peak Current (kA) at 230 / 400V C-Curve

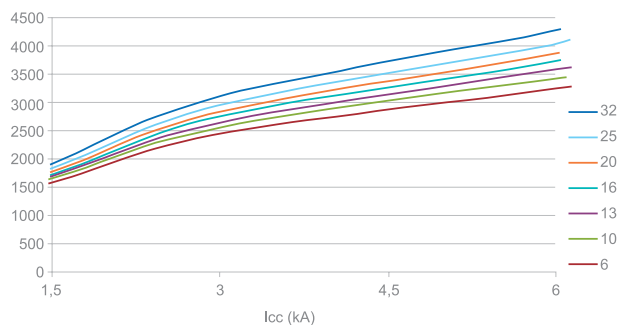

### Power Loss

In (A)	Voltage Drop (V)	Energy Loss Pw (W)	Resistance Z (mOhm)
6	0.26	43.6	1.57
8	0.16	19.4	1.242
10	0.16	15.6	1.56
13	0.155	11.9	2.011
16	0.162	10.1	2.566
20	0.138	6.9	2.76
25	0.128	5.1	3.188
32	0.096	3	3.188
40	0.1	2.5	4
50	0.09	1.8	4.5
63	0.082	1.3	5.16

### Let-through Energy I<sup>2</sup>t (A<sup>2</sup>s) C-Curve

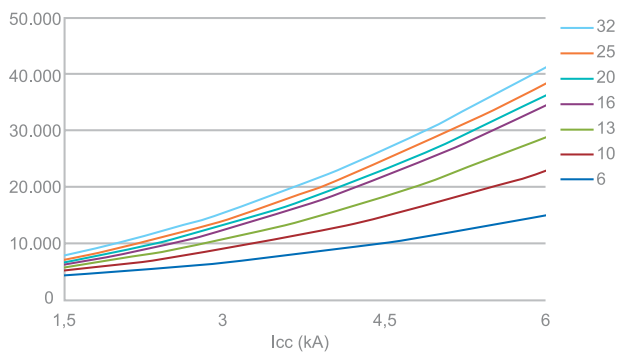

# DIN-Safe RCBO (2P Width)



- ✓ High speed and rapid arc quenching technology ensuring the highest level of protection is provided
- ✓ DIN rail mounting
- ✓ Free tripping mechanism even if toggle is locked or sealed ON or OFF
- ✓ Complies with AS/NZS 61009 (RCBOs)
- ✓ DSRCB RCBOs feature 10 kA short circuit rating (AI is 6 kA)
- ✓ Type A RCD
- ✓ Non-pigtail model with switched neutral
- ✓ Pigtail model with unswitched neutral
- ✓ 30 mA sensitivity general personnel protection applications
- ✓ 10 mA sensitivity option for higher risk applications
- ✓ 100 mA sensitivity option
- ✓ C trip curve for general light and power applications
- ✓ Fast connection pin / fork busbar comb
- ✓ Suits pole-covers, loadcentres and the Conecept range of Panelboards
- ✓ Approval No. NSW17482 or RCM
- ✓ 10 mA units compliant with Type 1 requirements



## General

Tripping Characteristics	C
Sensitivity $I\Delta n$	10, 30, 100 mA
RCD Type	A, AC, AI
Nominal Current Rating at 30 °C	6 - 40 A
Poles	1P + N
Switched Neutral	Yes

## Short Circuit

$I_{cn}$ 230 1P	-
$I\Delta m$	6

## Voltage

Frequency	50 / 60 Hz
Maximum Service Voltage $U_{bmax}$	255 V AC
Minimum Service Voltage $U_{bmin}$ <sup>1)</sup>	117 / 100

## Connections

Maximum Cable Size	Rigid / Flexible (Top)	25 mm <sup>2</sup> / 16 mm <sup>2</sup>
	Rigid / Flexible (Bottom)	35 mm <sup>2</sup> / 25 mm <sup>2</sup>

### Notes:

1) 100 V for 30 mA Type A unit only.

## Application



Light commercial and industrial general light and power applications. Suitable for use in loadcentres and the Concept range of Panelboards with 4P busbar chassis. AI type higher immunity to transit / surge currents 3000 A 8/20 us vs. 250 A 8/20 us.

## Connection

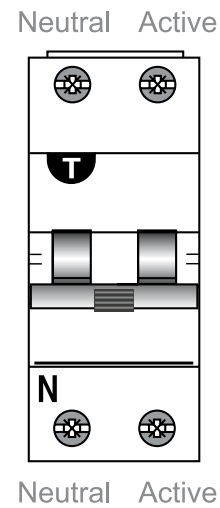

## Dimensions

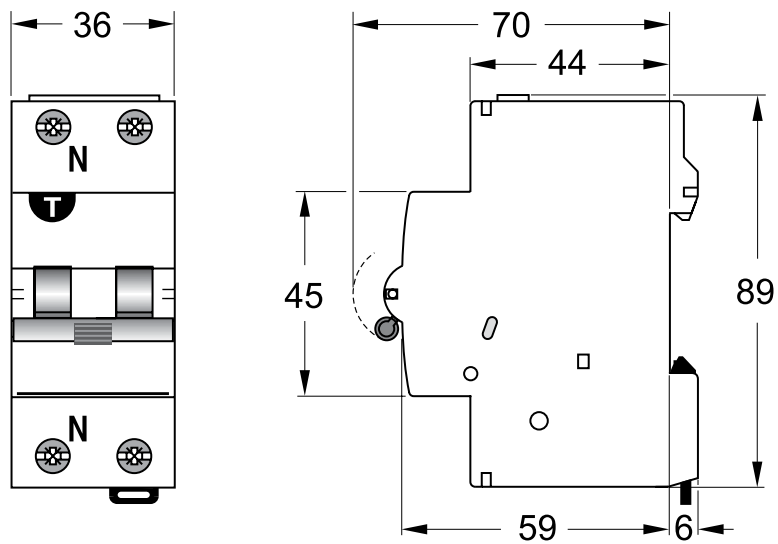



Without Pigtail

With Pigtail

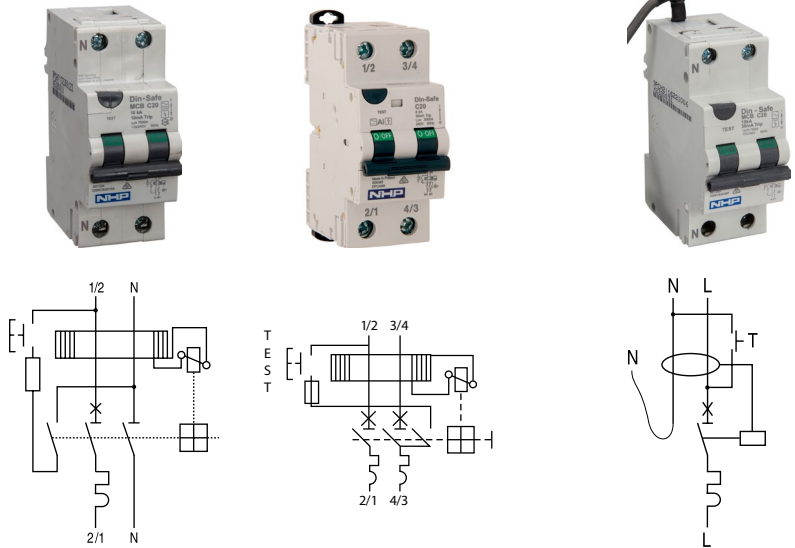

Sensitivity (mA)	Amps (In)	Width (mm)	Type A	Type AI	Type AC
10 mA	6	36	DSRCB0610A	-	-
	10	36	DSRCB1010A	-	-
	16	36	DSRCB1610A	-	-
	20	36	DSRCB2010A	-	-
30 mA	6	36	-	DSRCB0630AI	DSRCB0630P
	10	36	DSRCB1030A	DSRCB1030AI	DSRCB1030P
	16	36	DSRCB1630A	DSRCB1630AI	DSRCB1630P
	20	36	DSRCB2030A	DSRCB2030AI	DSRCB2030P
	25	36	DSRCB2530A	DSRCB2530AI	DSRCB2530P
	32	36	DSRCB3230A	DSRCB3230AI	DSRCB3230P
	40	36	DSRCB4030A	DSRCB4030AI	DSRCB4030P
100 mA	10	36	DSRCB10100A	-	-
	16	36	DSRCB16100A	-	-
	20	36	DSRCB20100A	-	-



## Voltage Ratings

Sensitivity $I_{\Delta n}$	10, 30, 100 mA	
Tripping Time at $I_{\Delta n}$	< 40 ms	
RCD Type	A, AC, AI	
Nominal current rating at 30 °C	6 - 40 A	
Poles	1P + N	
Switched Neutral	Yes	
Frequency	50 / 60 Hz	
Power Supply	Top / Bottom	
Maximum Service Voltage $U_{bmax}$	255 V AC	
Minimum Service Voltage $U_{bmin}$	117 V AC	
Isolator Application	IEC 60947-2	Yes
Rated Insulation Voltage	Pollution Degree 2	
Impulse Withstand Test Voltage	6 kV	
Insulation Resistance	1000 mOhm	
Dielectric Rigidity	2500 V	

## Environmental

Vibration Resistance (IEC 77 / 16.3) (in x, y, z direction)	1.5 g	
Endurance	Electrical at $U_n, I_n$	10000 cycles
	Mechanical	20000 cycles
Utilisation Category (IEC 60947-2)		
Protection Degree	Outside	IP20
	Inside	IP40
Self-extinguish Degree (According to UL94)	UL 94 V-2	
Tropicalisation (IEC60068-2 / DIN 40046)	+55 °C / 95 % RH	
Operating Temperature	-5°C / +55 °C	
Storage Temperature	-25 °C / +70 °C	

## Connection

Rigid Cable Min / Max (Top)	1 mm <sup>2</sup> / 25 mm <sup>2</sup>	
Flexible Cable Min / Max (Top)	1 mm <sup>2</sup> / 16 mm <sup>2</sup>	
Rigid Cable Min / Max (Bottom)	1 mm <sup>2</sup> / 35 mm <sup>2</sup>	
Flexible Cable Min / Max (Bottom)	1 mm <sup>2</sup> / 25 mm <sup>2</sup>	
Torque (Top / Bottom)	3 / 4 Nm	
Busbar	Connection Top	-
	Connection Bottom	Fork / Pin

## Physical

Dimensions (H x W x D)	1P + N	86 x 36 x 68 mm
Weight	0.25 kg	
Package	6 module	

## Short-Circuit Capacity

IEC 61009-1	Rated Making and Breaking Capacity ( $I_m$ )	-	A
	Residual Making and Breaking Capacity ( $I_{\Delta m}$ )	6000	A
	Conditional Short-Circuit Capacity ( $I_{nc}$ )	6	kA
	Conditional Residual Short-Circuit Capacity ( $I_{\Delta c}$ )	-	kA
	Rated Short-Circuit Capacity ( $I_{cn}$ )	10 <sup>1)</sup>	kA

### Notes:

1) 6 kA for Type AI.



### C-Curve Characteristics

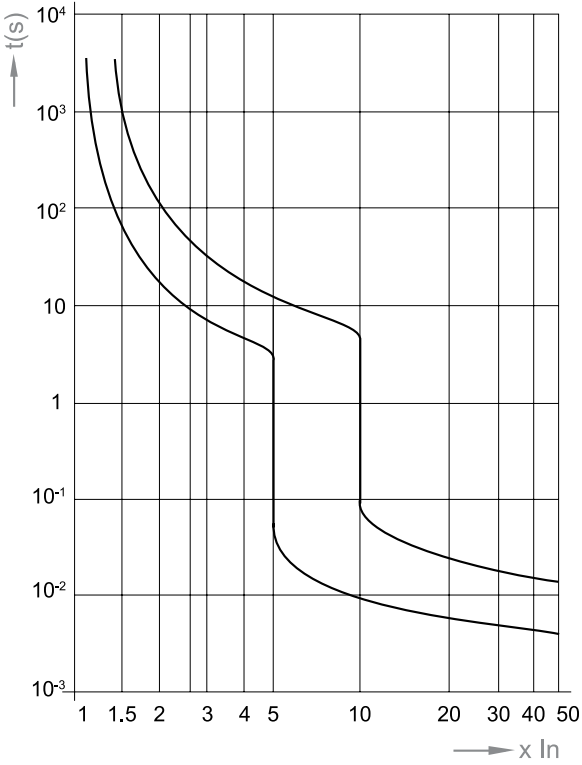

### Ambient Temperature Influence at 6 A

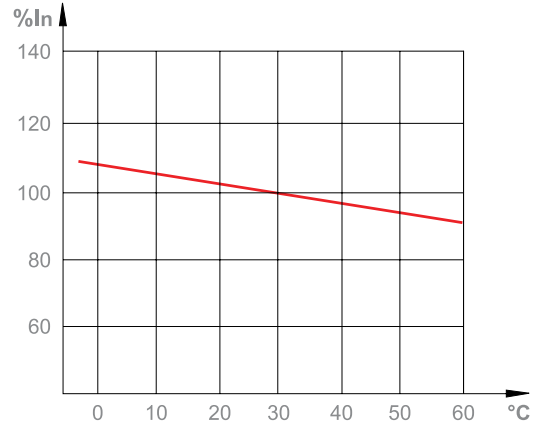

### Ambient Temperature Influence at 16-40 A

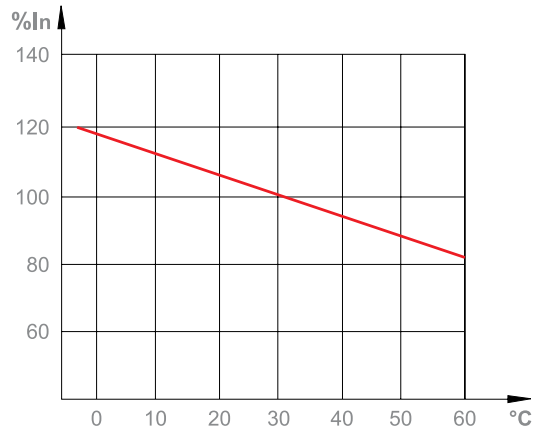

### Let-Through Energy $I^2 t$ (A<sup>2</sup> s) C-Curve

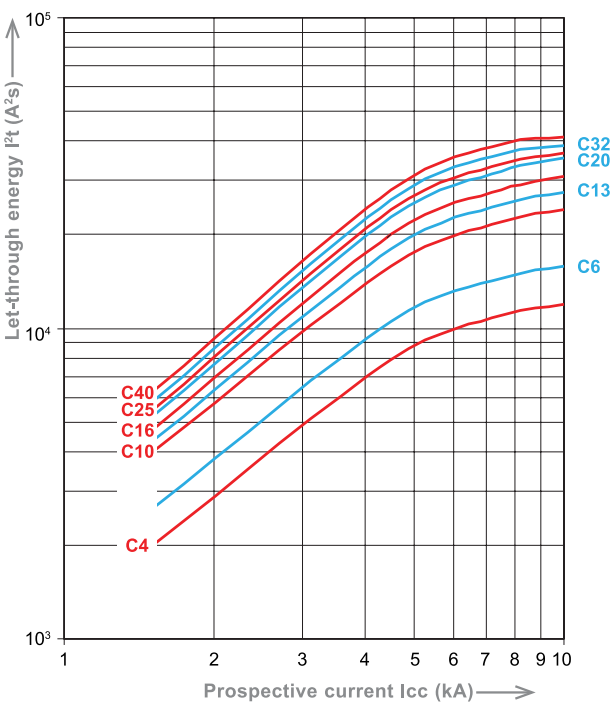

### Ambient Temperature Influence at 16-40 A

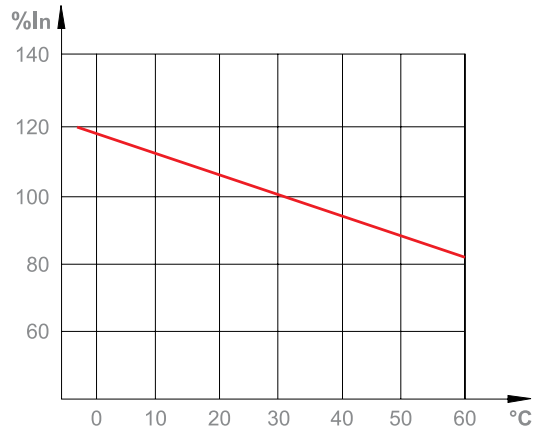



## Power Loss

In (A)	Energy Loss Pw (W)	Resistance Z (mOhm)
4	125	2
6	53	1.91
10	16.3	1.63
16	9.8	2.51
20	7.1	2.84
25	5.6	3.5
32	4.7	4.81
40	3.6	5.76

# DIN-Safe Safety Switches (RCCBs)



- ✓ DIN rail mounting
- ✓ Free tripping mechanism even if toggle is locked or sealed ON or OFF
- ✓ Complies with AS/NZS 61008 (RCCBs)
- ✓ DIN-SAFE RCCBs feature 10kA conditional short circuit rating
- ✓ 1P+N and 3P+N for single or three phase loads
- ✓ Type A, AI, F, and B RCD options
- ✓ 30 mA sensitivity featured as standard simplifying the selection for personnel protection applications
- ✓ 100 mA, 300 mA, and 500 mA sensitivity options
- ✓ Fast connection pin / fork busbar comb or busbar chassis
- ✓ Suits pole-covers and loadcentres
- ✓ Approval No. NSW17482 or RCM

Type A, AI



Type F



Type B



## General

Sensitivity $I_{\Delta n}$	30, 100, 300 mA
RCD Type	A, AI, B, F
Nominal Current Rating at 30 °C	40 - 100 A
Poles	1P + N / 3P + N
Switched Neutral	Yes

## Short Circuit

$I_{\Delta vc}$ Condition Short Circuit Capacity	10000
$I_{nc}$ Condition Short Circuit Capacity	10

## Voltage

Frequency	50 / 60 Hz
Maximum Service Voltage $U_{bmax}$ (2P / 4P)	265 / 455 V AC
Minimum Service Voltage $U_{bmin}$ (2P / 4P)	117 / 205

## Connections

Maximum Cable Size	Rigid / Flexible (Top)	50 mm <sup>2</sup> / 35 mm <sup>2</sup>
	Rigid / Flexible (Bottom)	50 mm <sup>2</sup> / 35 mm <sup>2</sup>





## Application

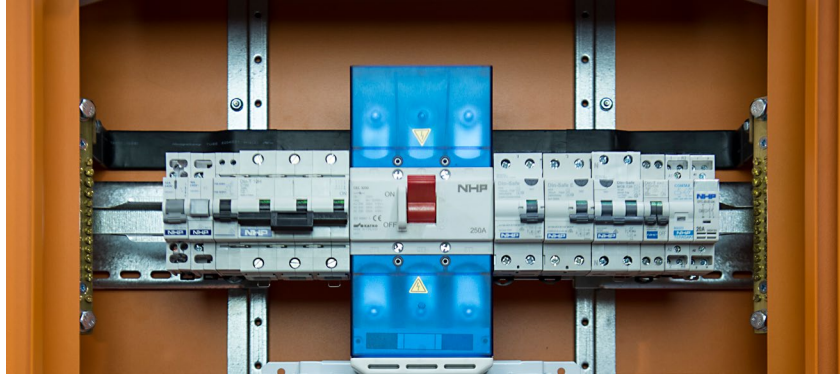

Light commercial general light, and power applications and EV charging stations. Suitable for use in pole-covers and loadcenter. Type AC for general applications, Type A protects as per Type AC and additionally for rectified loads, Type F protects as per Type A and additionally for high frequency leakages, Type B protects as per Type F and additionally for pure DC leakages. Type B is recommended for EV chargers and drives.

## Connection

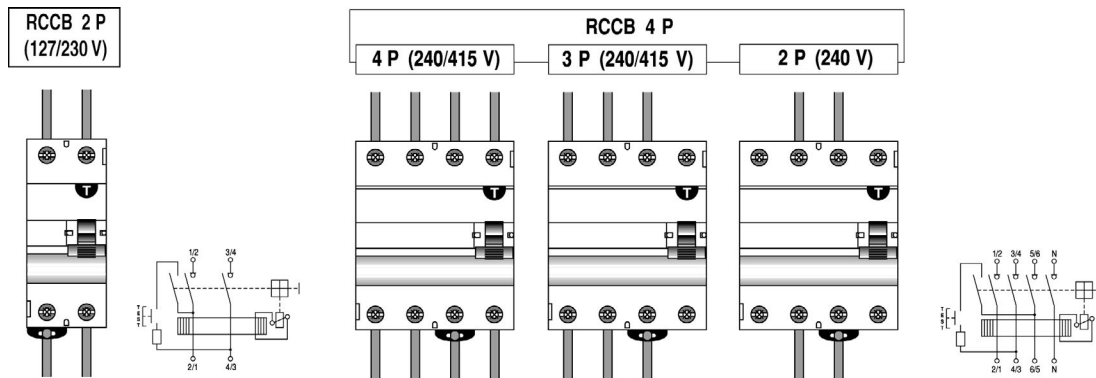

## Dimensions

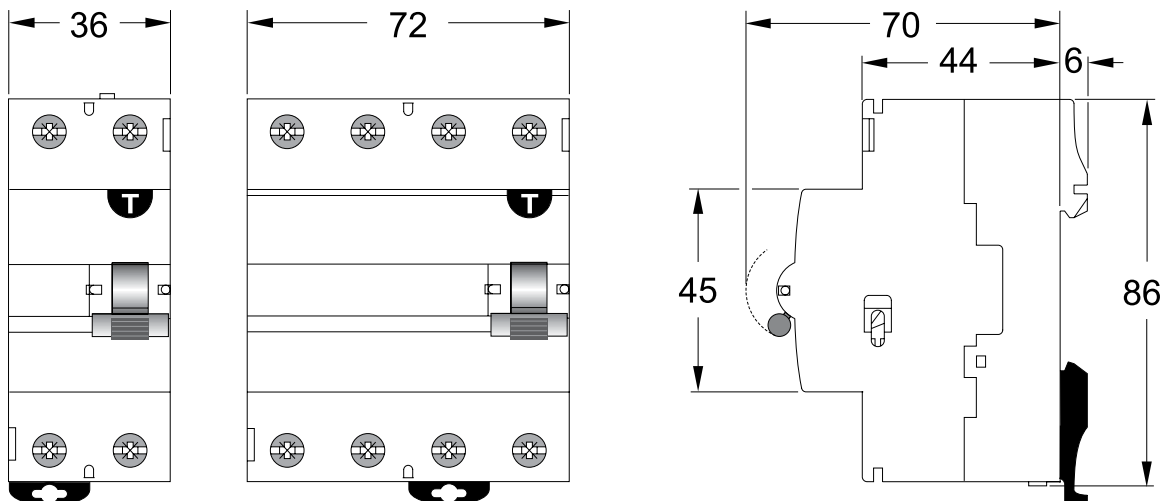



1P + N

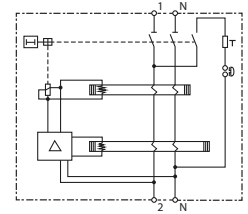
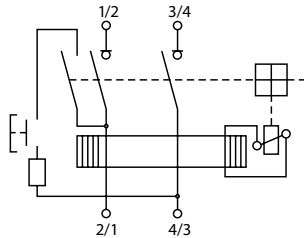

Sensitivity (mA)	Amps (A)	Width (mm)	Type A	Type AI	Type F	Type B
30	40	36	DSRCD24030A	DSRCD24030AI	DSRCD24030F	-
	63	36	DSRCD26330A	DSRCD26330AI	-	DSRCD26330B
	80	36	DSRCD28030A	-	-	-
100	40	36	DSRCD240100A	-	-	-
	63	36	-	-	-	DSRCD263100B
	80	36	DSRCD280100A	-	-	-

3P + N

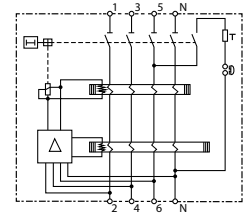
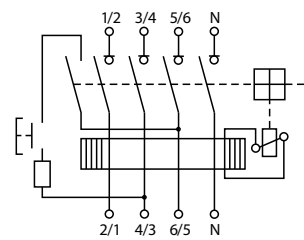

Sensitivity (mA)	Amps (A)	Width (mm)	Type A	Type AI	Type F	Type B
30	40	72	DSRCD44030A	DSRCD44030AI	DSRCD44030F	-
	63	72	DSRCD46330A	DSRCD46330AI	-	DSRCD46330B
	100	72	DSRCD410030A	-	-	-
100	40	72	DSRCD463100A	-	-	-
	63	72	-	-	-	DSRCD463100B
	80	72	DSRCD480100A	-	-	-
300	63	72	-	-	-	DSRCD463300B
	80	72	-	-	-	DSRCD480300B

## Voltage Ratings

Sensitivity $I_{\Delta n}$	30, 100, 300 mA	
Tripping Time at $I_{\Delta n}$	< 40 ms	
RCD Type	A, AI, B, F	
Nominal Current Rating at 30 °C	40 - 100 A	
Poles	1P + N / 3P + N	
Switched Neutral	Yes	
Frequency	50 / 60 Hz	
Power Supply	Top / Bottom	
Maximum Service Voltage $U_{bmax}$	265 / 455 V AC	
Minimum Service Voltage $U_{bmin}$	205 V AC	
Isolator Application	IEC 60947-2	Yes
Rated Insulation Voltage	Pollution Degree 2	440 V
Impulse Withstand Test Voltage	6 kV	
Insulation Resistance	1000 mOhm	
Dielectric Rigidity	2500 V	

## Environmental

Vibration Resistance (IEC 77 / 16.3) (in x, y, z direction)	1.5 g	
Endurance	Electrical at $U_n, I_n$	10000 cycles
	Mechanical	20000 cycles
Utilisation Category (IEC 60947-2)		
Protection Degree	Outside	IP20
	Inside	IP40
Self-extinguish Degree (According to UL94)	UL 94 V-2	
Tropicalisation (IEC60068-2 / DIN 40046)	+55 °C / 95 % RH	
Operating Temperature	-25 °C / +55 °C	
Storage Temperature	-25 °C / +70 °C	

## Connection

Rigid Cable Min / Max (Top)	1.5 mm <sup>2</sup> / 50 mm <sup>2</sup>	
Flexible Cable Min / Max (Top)	1.5 mm <sup>2</sup> / 35 mm <sup>2</sup>	
Rigid Cable Min / Max (Bottom)	1.5 mm <sup>2</sup> / 50 mm <sup>2</sup>	
Flexible Cable Min / Max (Bottom)	1.5 mm <sup>2</sup> / 35 mm <sup>2</sup>	
Torque (Top / Bottom)	5 / 5 Nm	
Busbar	Connection Top	Fork / Pin
	Connection Bottom	Fork / Pin

## Physical

Dimensions (H x W x D)	1P + N	86 x 36 x 76 mm
	3P + N	86 x 72 x 76 mm
Weight	0.25 / 0.368 kg	
Package	6 / 3 module	

## Short-Circuit Capacity

IEC 61008-1	Rated Making and Breaking Capacity ( $I_m$ )	500	A
	Residual Making and Breaking Capacity ( $I_{\Delta m}$ )	500	A
	Conditional Short-Circuit Capacity ( $I_{nc}$ )	10	kA
	Conditional Residual Short-Circuit Capacity ( $I_{\Delta c}$ )	10	kA

## Power Loss

In (A)	Resistance Z (mOhm)	Energy Loss Pw (W)
16	9.94	2.55
25	3.75	2.33
40	2.15	3.43
63	1.3	5.15
80	1.3	8.3
100	0.87	8.7

# DIN-Safe RCCB Add-on Module (DSRCM)

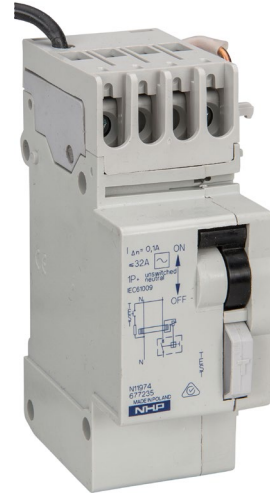

- ✓ High speed and rapid arc quenching technology ensuring the highest level of protection is provided
- ✓ DIN rail mounting
- ✓ Free tripping mechanism even if toggle is locked or sealed ON or OFF
- ✓ Complies with AS3190 (RCCBs)
- ✓ DIN-SAFE Add-on-Modules feature 10 kA conditional short circuit rating
- ✓ 1P+N, 3P and 3P+N for single or three phase loads
- ✓ Type AC RCD
- ✓ 30 mA, 100 mA, 300 mA RCD options
- ✓ Suits pole-covers, loadcentres and the Concept range of Panelboards
- ✓ Approval No. N11974 or RCM



## General

<b>Sensitivity <math>I_{\Delta n}</math></b>	30, 100, 300 mA
<b>RCD Type</b>	AC
<b>Nominal Current Rating at 30 °C</b>	32 - 63 A
<b>Poles</b>	1P + N / 3P + N / 3P

## Switched Neutral

## Short Circuit

### $I_{\Delta vc}$ Condition Short Circuit Capacity

### $I_{nc}$ Condition Short Circuit Capacity

## Voltage

<b>Frequency</b>	50 / 60 Hz
<b>Maximum Service Voltage <math>U_{bmax}</math> (2P / 4P)</b>	265 / 455 V AC
<b>Minimum Service Voltage <math>U_{bmin}</math> (2P / 4P)</b>	176 / 287

## Connections

<b>Maximum Cable Size</b>	<b>Rigid / Flexible (Top)</b>	25 mm <sup>2</sup> / 25 mm <sup>2</sup>
	<b>Rigid / Flexible (Bottom)</b>	- / -



## Application

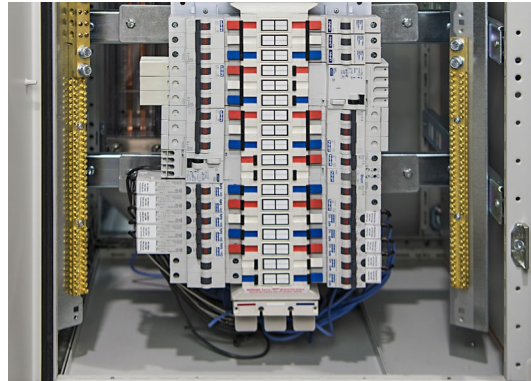

Commercial general light and power 3 phase applications. Suitable for use in pole-covers, loadcentres fork or pin busbar comb and the Concept range of Panelboards using busbar chassis.

## Connection

Din-Safe-M  
1P + N with 1 pole MCB

(Neutral not switched)

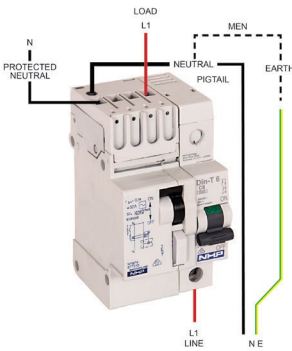

Din-Safe-M  
1P + N with 2 pole MCB

(Switching active + neutral)

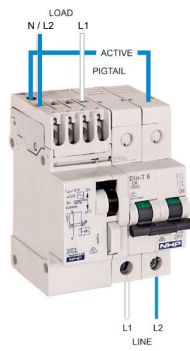

Din-Safe-M  
3P + N with 3 pole MCB

(Neutral not switching)

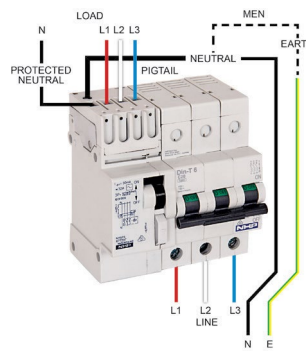

Din-Safe-M  
3P + N with 4 pole MCB

(Switching active + neutral)

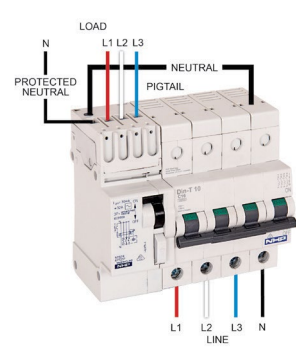

## Dimensions

1 P+N

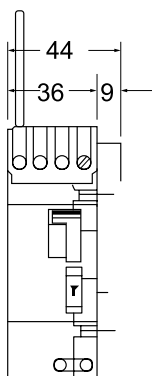

3 P+N

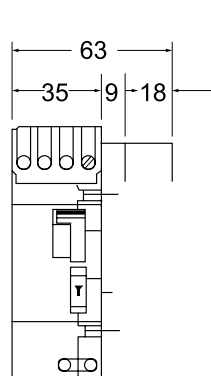

3 P+N

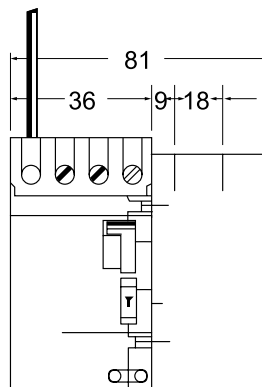

3 P

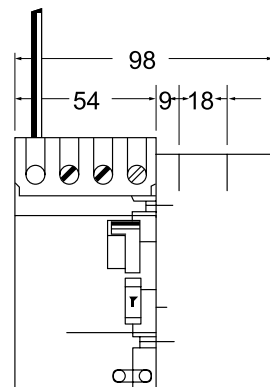

MCBs and RCBOs

## 1P + N

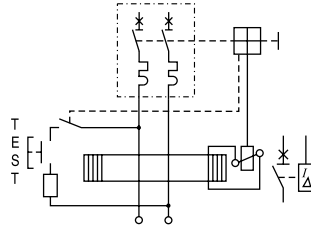

Sensitivity (mA)	Amps (In)	Width (mm)	Type AC
30	32	36	DSRCM32301PN
100	32	36	DSRCM321001PN
300	32	36	DSRCM323001PN

## 1P + N

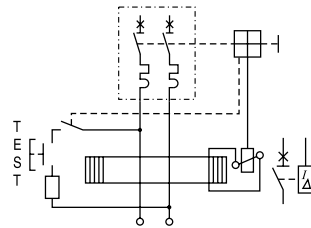

Sensitivity (mA)	Amps (In)	Width (mm)	Type AC
30	63	36	DSRCM63301PN
100	63	36	DSRCM631001PN
300	63	36	DSRCM633001PN

## 3P + N

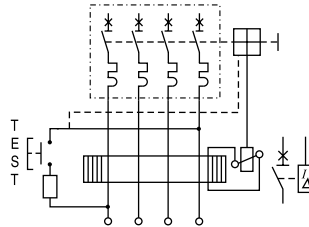

Sensitivity (mA)	Amps (In)	Width (mm)	Type AC
30	32	36	DSRCM32303PN
100	32	54	DSRCM321003PN
300	32	54	DSRCM323003PN

## 3P + N

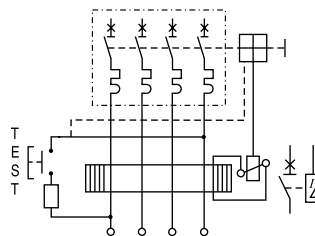

Sensitivity (mA)	Amps (In)	Width (mm)	Type AC
30	63	54	DSRCM63303PN
100	63	54	DSRCM631003PN
300	63	54	DSRCM633003PN

## 3P

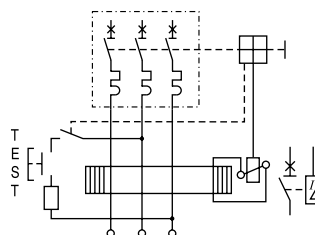

Sensitivity (mA)	Amps (In)	Width (mm)	Type AC
30	63	54	DSRCM63303P
100	63	54	DSRCM631003P
300	63	54	DSRCM633003P

## Voltage Ratings

Sensitivity $I_{\Delta n}$	30, 100, 300 mA	
Tripping Time at $I_{\Delta n}$	< 40 ms	
RCD Type	AC	
Nominal Current Rating at 30 °C	32 - 63 A	
Poles	1P + N / 3P + N / 3P	
Switched Neutral		
Frequency	50 / 60 Hz	
Power Supply	-	
Maximum Service Voltage $U_{bmax}$	265 / 455 V AC	
Minimum Service Voltage $U_{bmin}$	287 V AC	
Isolator Application	IEC 60947-2	-
Rated Insulation Voltage	Pollution Degree 2	-
Impulse Withstand Test Voltage	-	
Insulation Resistance	1000 mOhm	
Dielectric Rigidity	2500 V	

## Environmental

Vibration Resistance (IEC 77 / 16.3) (in x, y, z direction)	5 g	
Endurance	Electrical at $U_n, I_n$	10000 cycles
	Mechanical	20000 cycles
Utilisation Category (IEC 60947-2)	-	
Protection Degree	Outside	IP20
	Inside	IP40
Self-extinguish Degree (According to UL94)	UL 94 V-2	
Tropicalisation (IEC60068-2 / DIN 40046)	+60 °C / 95 % RH	
Operating Temperature	-5 °C / +60 °C	
Storage Temperature	-25 °C / +70 °C	

## Connection

Rigid Cable Min / Max (Top)	- / 25 mm <sup>2</sup>	
Flexible Cable Min / Max (Top)	- / 25 mm <sup>2</sup>	
Rigid Cable Min / Max (Bottom)	1 mm <sup>2</sup> / -	
Flexible Cable Min / Max (Bottom)	1 mm <sup>2</sup> / -	
Torque (Top / Bottom)	- / 4.5 Nm	
Busbar	Connection Top	-
	Connection Bottom	-

## Physical

Dimensions (H x W x D)	1P + N	86 x 36 x 76 mm
	1P + N	86 x 36 x 76 mm
	3P + N	86 x 36 x 76 mm
Weight	0.25 / 0.34 / 0.32 kg	
Package	1 module	

## Short-Circuit Capacity

IEC 61008-1	Rated Making and Breaking Capacity ( $I_m$ )	-	A
	Residual Making and Breaking Capacity ( $I_{\Delta m}$ )	-	A
	Conditional Short-Circuit Capacity ( $I_{nc}$ )	-	kA
	Conditional Residual Short-Circuit Capacity ( $I_{\Delta c}$ )	-	kA



# DIN-Safe Easy-Fit RCCBs (2P Width)



- ✓ DIN rail mounting
- ✓ Free tripping mechanism even if toggle is locked or sealed ON or OFF
- ✓ Complies with AS/NZS 61008 (RCCBs)
- ✓ DIN-Safe Easy-fit RCCBs feature 10 kA conditional short circuit rating
- ✓ 1P+N and 3P+N for single or three phase loads
- ✓ Type A RCD
- ✓ 30 mA sensitivity featured as standard simplifying the selection for personnel protection applications
- ✓ Cable clamping technology
- ✓ Suits pole-covers and loadcentres
- ✓ Approval No. NSW24783 or RCM
- ✓ Bottom terminal cable clamp busbar



## General

Sensitivity $I_{\Delta n}$	30 mA
RCD Type	A
Nominal Current Rating at 30 °C	40 - 63 A
Poles	1P + N / 3P + N
Switched Neutral	Yes

## Short Circuit

$I_{\Delta v c}$ Condition Short Circuit Capacity	10000
$I_{nc}$ Condition Short Circuit Capacity	10

## Voltage

Frequency	50 / 60 Hz
Maximum Service Voltage $U_{bmax}$ (2P / 4P)	255 / 455 V AC
Minimum Service Voltage $U_{bmin}$ (2P / 4P)	110 / 190

## Connections

Maximum Cable Size	Rigid / Flexible (Top)	50 mm <sup>2</sup> / 35 mm <sup>2</sup>
	Rigid / Flexible (Bottom)	25 mm <sup>2</sup> / 16 mm <sup>2</sup>



## Application

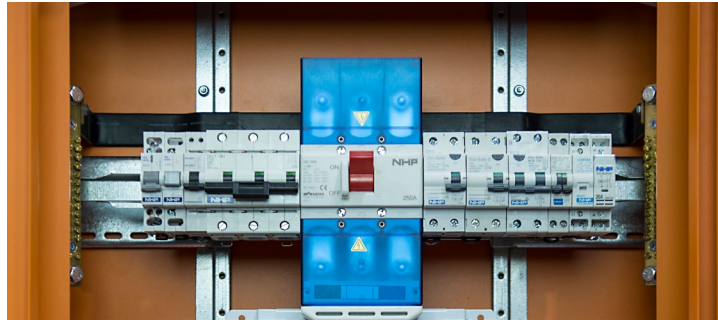

Light commercial general light and power applications. Suitable for use in pole-covers and loadcentres.

## Connection

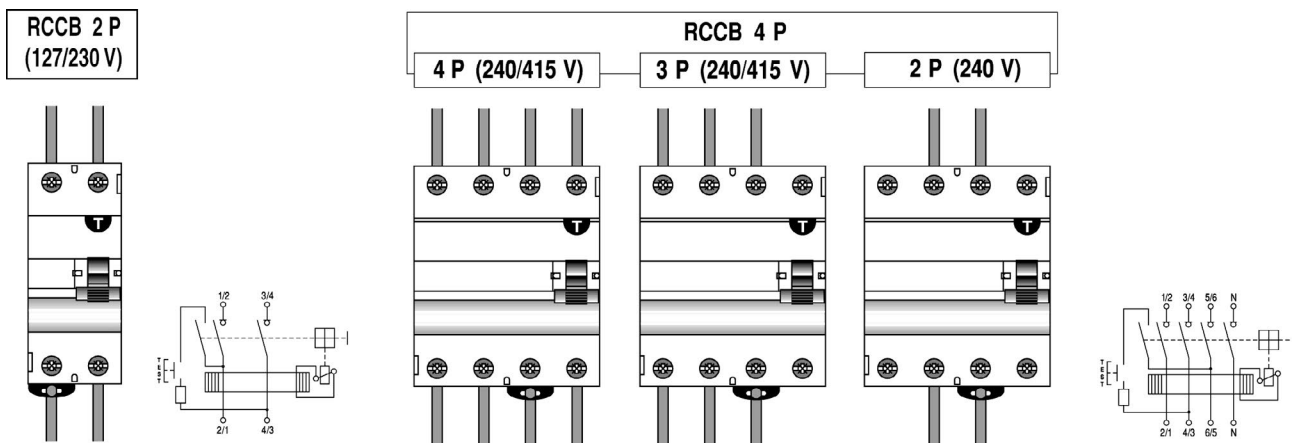

## Dimensions

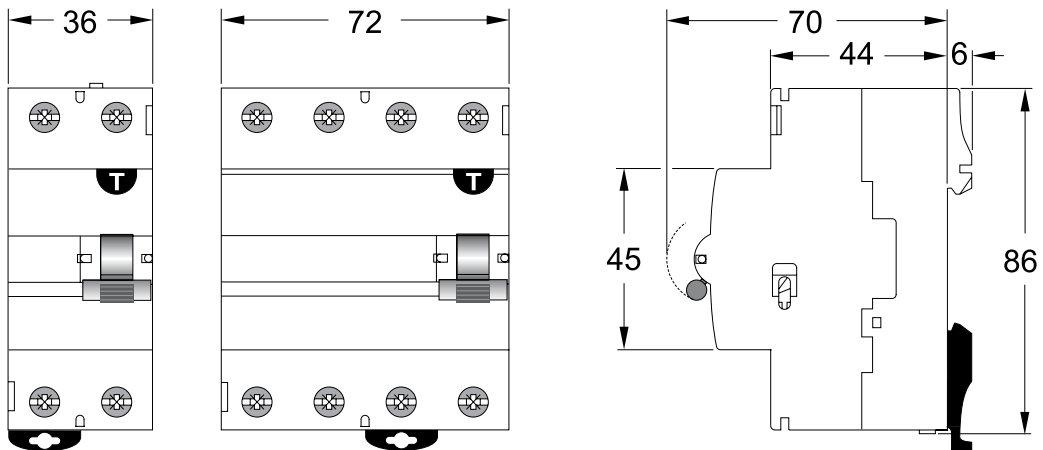

## 1P + N

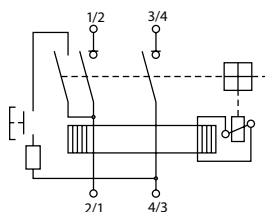

Sensitivity (mA)	Amps (A)	Width (mm)	Type AC
30	40	36	DSRCDE24030
	63	36	DSRCDE26330

## 3P + N

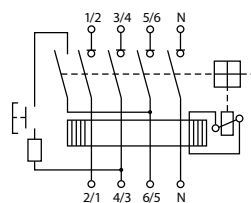

Sensitivity (mA)	Amps (A)	Width (mm)	Type AC
30	40	72	DSRCDE44030
	63	72	DSRCDE46330

## Voltage Ratings

Sensitivity $I_{\Delta n}$		30 mA
Tripping Time at $I_{\Delta n}$		< 40 ms
RCD Type		AC
Nominal Current Rating at 30 °C		40 - 63 A
Poles		1P + N / 3P + N
Switched Neutral		Yes
Frequency		50 / 60 Hz
Power Supply		Top / Bottom
Maximum Service Voltage $U_{bmax}$		255 / 455 V AC
Minimum Service Voltage $U_{bmin}$		110 / 190 V AC
Isolator Application	IEC 60947-2	Yes
Rated Insulation Voltage	Pollution Degree 2	-
Impulse Withstand Test Voltage		8 kV
Insulation Resistance		1000 mOhm
Dielectric Rigidity		2500 V

## Environmental

Vibration Resistance (IEC 77 / 16.3) (in x, y, z direction)		1.5 g
Endurance	Electrical at $U_n, I_n$	10000 cycles
	Mechanical	20000 cycles
Utilisation Category (IEC 60947-2)		-
Protection Degree	Outside	IP20
	Inside	IP40
Self-extinguish Degree (According to UL94)		UL 94 V-2
Tropicalisation (IEC60068-2 / DIN 40046)		+55 °C / 95 %RH
Operating Temperature		-25 °C / +60 °C
Storage Temperature		-25 °C / +70 °C

## Connection

Rigid Cable Min / Max (Top)		1.5 mm <sup>2</sup> / 50 mm <sup>2</sup>
Flexible Cable Min / Max (Top)		1.5 mm <sup>2</sup> / 35 mm <sup>2</sup>
Rigid Cable Min / Max (Bottom)		1 mm <sup>2</sup> / 25 mm <sup>2</sup>
Flexible Cable Min / Max (Bottom)		0.75 mm <sup>2</sup> / 16 mm <sup>2</sup>
Torque (Top / Bottom)		2.5 Nm
Busbar	Connection Top	Fork / Pin
	Connection Bottom	Fork / Pin

## Physical

Dimensions (H x W x D)	1P + N	86 x 36 x 76 mm
	3P + N	86 x 72 x 76 mm
Weight		246 / 364 kg
Package	6 / 3 module	116, 113

## Short-Circuit Capacity

IEC 61008-1	Rated Making and Breaking Capacity ( $I_m$ )	500	A
	Residual Making and Breaking Capacity ( $I_{\Delta m}$ )	500	A
	Conditional Short-Circuit Capacity ( $I_{nc}$ )	10	kA
	Conditional Residual Short-Circuit Capacity ( $I_{\Delta c}$ )	10	kA

## Power Loss

In (A)	Resistance Z (mOhm)	Energy loss $P_w$ (W)
40	2.15	3.43
63	1.3	5.15
80	1.3	8.3
100	0.87	8.7



## Pin Type Busbar Combs

### IBC Type - 1-Phase (Comes Complete with End Caps)

Suitable for linking regular 18 mm pitch terminals, DIN-T Main Switches, MCBs and RCBOs in a loadcenter or in a control centre. Pin type busbar comb utilises the devices main tunnel terminal.

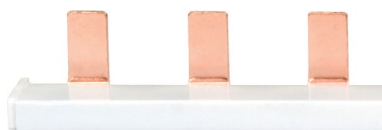

Item Description	Catalogue No.
Busbar Comb, 8 way, 100 A, 1P pin type with end caps	IBC108P
Busbar Comb, 12 way, 100 A, 1P, Pin type with end caps	IBC112P
Busbar Comb, 15 way, 100 A, 1P, Pin type with end caps	IBC115P
Busbar Comb, 18 way, 100 A, 1P, Pin type with end caps	IBC118P
Busbar Comb, 21 way, 100 A, 1P pin type with end caps	IBC121P
Busbar Comb, 55 way, 100 A, 1P pin type with end caps	IBC155P

## ICL Type - 2P, 3P and 3P+N

Suitable for linking regular 18 mm pitch terminals, DIN-T Main Switches, MCBs and RCBOs in a loadcenter or in a control centre. Pin type busbar comb utilises the devices main tunnel terminal.

Close up of pins

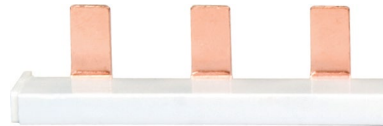
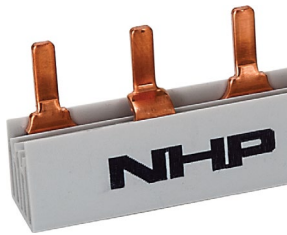

Item Description	Catalogue No.
Busbar Comb 6 way, 80 A / 130 A, 1P+N, Pin type	ICL62
Busbar Comb, 10 way, 80 A / 130 A, 1P+N, Pin type	ICL102
Busbar Comb, 56 way, 80 A / 130A, 1P+N, Pin type	ICL562

Item Description	Catalogue No.
Busbar Comb, 12 way, 80 A / 130 A, 3P, Pin type	ICL123
Busbar Comb, 15 way, 80 A / 130 A, 3P, Pin type	ICL153
Busbar Comb, 18 way, 80 A / 130 A, 3P, Pin type	ICL183
Busbar Comb, 21 way, 80 A / 130 A, 3P, Pin type	ICL213
Busbar Comb 57 way, 80 A / 130 A, 3P, Pin type	ICL573



Item Description	Catalogue No.
Busbar Comb 56 way, 80 A / 130 A, 3P+AUX, Pin type	ICL563A
Busbar Comb 56 way, 80 A / 130 A, 3P+N, Pin type	ICL564

## IBD Type - 3P

Suitable for linking 9 mm pitch terminals, 2-in-1 MCBs and RCBOs in a loadcenter or in a control centre. Pin type busbar comb utilises the devices main tunnel terminal.



Item Description	Catalogue No.
Busbar Comb 12 way, 80 A / 100 A, 3P, suit DTCBD	IBD312P
Busbar Comb 55 way, 80 A / 100 A, 3P, suit DTCBD	IBD355P
Busbar Comb 55 way, 80 A / 100 A, 3P+N, pin type, suits 2P M6RCBD and DTCBD	IBD4552P
Busbar Comb 55 way, 80 A / 100 A, 3P+N, pin type, suits DTCBD64	IBD4554P

## Busbar Comb End Caps

End caps to cover the end of cut busbar comb.



Item Description	Catalogue No.
Buscomb End Cap to suit 2P and 3P IBD	ICLEC23
Buscomb End Cap to suit 3P+N ICL	ICLEC4

## Busbar Comb Tee-off Cap

Barrier / cover to bare tee-offs on busbar comb.

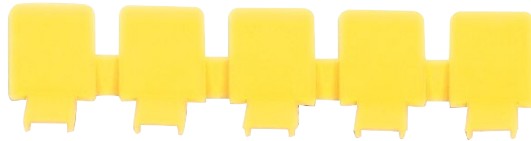

Item Description	Catalogue No.
Buscomb Tee-off Caps Yellow (Strip of 5)	ICLTOC

## Terminal Connectors

Allows connection of cable to terminal, either larger cable or changes direction for cable termination.

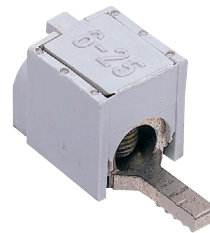

Item Description	Catalogue No.	Item Description	Catalogue No.
Buscomb Terminal Feeder 35 mm	DTCF35	Terminal Axial Pin 25 mm <sup>2</sup> (Insulated) to suit DIN MCBs	DTTAX25PN



**Item Description****Catalogue No.**

Terminal Axial Spade 25 mm (insulated) to suit DIN MCBs

DTTAX25SP

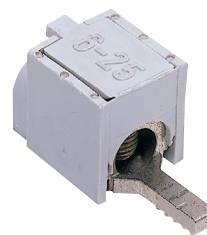
**Item Description****Catalogue No.**

Terminal Axial Pin 50 mm (insulated) to suit DIN MCBs

DTTAX50PN

**Item Description****Catalogue No.**

Terminal Long Lateral Pin 35 mm to suit DIN MCBs

DTTTL35LPN

**Item Description****Catalogue No.**

Terminal Lateral Pin 35 mm to suit DIN MCBs

DTTTL35PN

**Item Description****Catalogue No.**

Terminal Lateral Spade 35 mm to suit DIN MCBs

DTTTL35SP



## Terminal Covers & Pole Fillers

Barrier / cover to MCBs, RCBOs or fills void/cut-out in an escutcheon.

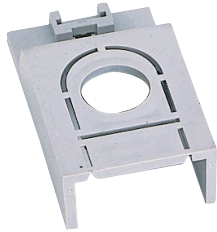

Item Description	Catalogue No.
Terminal Cover suits DIN-T10H	DINT10HTC



Item Description	Catalogue No.
Terminal Cover 35mm suits DSRCBH	DSRCBHTC



Item Description	Catalogue No.
DIN Dummy MCB (Filler for touch protection)	DTLDM



Item Description	Catalogue No.
DIN Spacer 1/2 Module 9mm width	DTSP



Item Description	Catalogue No.
Terminal Cover 35 mm suits DIN-T MCBs	DTTC35



Item Description	Catalogue No.
Terminal Cover 5 mm suits DIN-T MCBs	DTTC5

## Other Lock Dogs (Non-Captive and Captive)

Allows for MCBs, RCBOs to be locked off by means of customer supplied padlock.



Item Description	Catalogue No.
DIN-T Metal Lock Dog Captive 6.5 mm	DCLD6



Item Description	Catalogue No.
DIN-T10H Lock Dog, Non-Captive suits hasp up to 7.0 mm.	DTLDH



Item Description	Catalogue No.
DIN Lock Dog, Non-Captive suits hasp up to 8.0 mm.	DTLD

## LOCKDIN

### Locking Devices

Captive locking system for MCBs, RCBOs to be securely locked off by means of customer supplied padlock up to 7.0 mm.

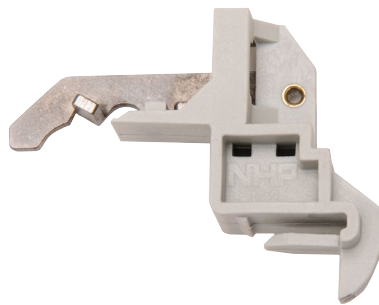

Item Description	Catalogue No.
LOCKDIN Left Hand Locking Assembly for MCBs and DSRCBH	DTLLA
LOCKDIN Right Hand Locking Assembly for MCBs and DSRCBH	DTLLARH
LOCKDIN Left Hand Locking Assembly for 2 Pole RCBOs	DTLLAB
LOCKDIN Right Hand Locking Assembly for 2 Pole RCBOs	DTLLABRH
LOCKDIN DIN-T10H Ldog 3-6 mm LH	DTLLA10H
LOCKDIN Left Hand Locking Assembly for MCBs and DSRCBH (12 Pack)	DTLLABULK
LOCKDIN Right Hand Locking Assembly for MCBs and DSRCBH (12 Pack)	DTLLARHBULK

## Pole Fillers and Blanking Devices

Captive locking system for MCBs, RCBOs to be securely locked off by means of customer supplied padlock.

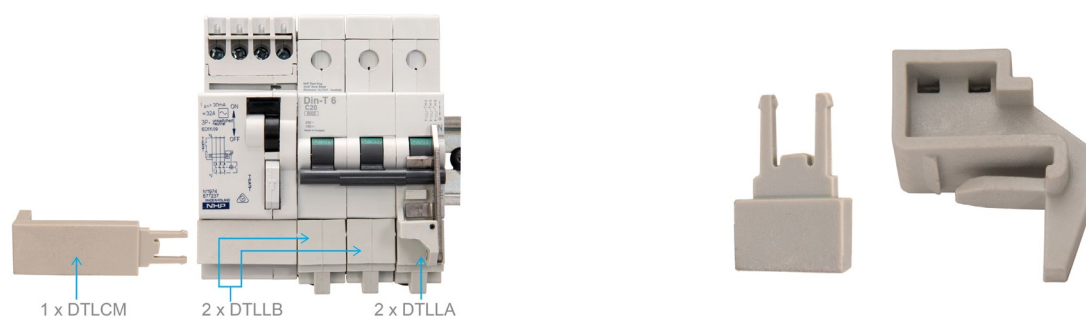

Item Description	Catalogue No.
LOCKDIN Locking Blank for DSRCM (Add On RCCB), 3 Pole MCBs	DTLCM

Item Description	Catalogue No.
LOCKDIN Locking Blank for MCBs and DSRCBH (12 Pack)	DTLLB



Item Description	Catalogue No.
LOCKDIN Pole Filler Extended Length to suit 63 mm Cutout (12 Pack)	DTLPPF



## Additional Accessories

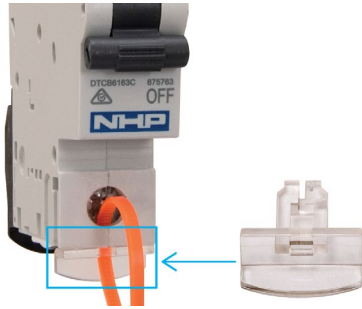

Item Description	Catalogue No.
DIN-T Sealing Plate 4 pack suits DIN-T MCBs	DTCBSEALPLATE

Item Description	Catalogue No.
DIN-T Panel Board Switch 1P. Trips connected MCB when escutcheon is opened.	DTPBS



Item Description	Catalogue No.
RESIN	LOCTITE480



## DIN-T Add-on Modules

MCB Accessories Compatibility Table	153
RCD Accessories Compatibility Table	153
Common Add-On Devices Suitable for All MCBs and RCDs	154
MCBs- DIN-T6, DIN-T10, DIN-T15, DIN-TDC & DIN-T Easy-Fit	155
MCBs- DIN-T6 2-in-1	155
MCBs- DIN-T10H	156
ISOLATOR- DIN-TMS	156
RCCB– DSRCB	157
RCBOs- DSRCBS	157
RCBOs– DSRCB	158
RCBO– DSRCBxxAI	158
DIN-T Main Switches	159



DIN-T Shunt Trip	161
DIN-T Undervoltage Trip	165
DIN-T Auxiliaries	169
DIN-T Changeover Switch	174
DIN-T Contactors	177
DIN Contactors	187
DIN-T Pushbuttons and Pilot Lights	188
DIN-T Motor Operator	191
DIN-T Impulse Switch	194
DIN-T Hour Run Counter	197



## MCB Accessories Compatibility Table

Part	Description	DIN-T6	DIN-T10	Din-T15	DIN-TDC	DIN-T Easy-Fit	DIN-T 2-in-1	DIN-T10H	DIN-TMS
DTAUXAL	Signal or Auxiliary Contact	LH/RH	LH/RH	LH/RH	LH/RH	LH/RH	LH/RH	-	LH/RH
DTAUXALG	Signal or Auxiliary Gold Contact	LH/RH	LH/RH	LH/RH	LH/RH	LH/RH	LH/RH	-	LH/RH
DINT10HHS	Signal or Auxiliary Contact	-	-	-	-	-	-	-/RH	-
DSRCBSAX	Auxiliary Contact	-	-	-	-	LH/RH	-	-	-
DSRCBSAXAL	Signal or Auxiliary Contact	-	-	-	-	LH/RH	-	-	-
DTPBS	Panelboard Switch	LH/RH	LH/RH	LH/RH	LH/RH	LH/RH	LH/RH	-	-
DINTSHT	Shunt Trip	-	-	-	-	-	-	LH/-	-
DTSHT	Shunt Trip	LH/RH	LH/RH	LH/RH	LH/RH	LH/RH	LH/RH	-	-
DTUVT	Undervoltage Trip	LH/RH	LH/RH	LH/RH	LH/RH	LH/RH	LH/RH	-	-
DTMD	Motor Operator	LH/RH	LH/RH	LH/RH	LH/RH	LH/RH	LH/RH	-	-

## RCD Accessories Compatibility Table

Part	Description	DSRCBS	DSRCBH	DSRCB	DSRCBxxAI	DSRCD
DTAUXAL	Signal or Auxiliary Contact	-/RH	-	-/RH	LH/RH	-/RH
DTAUXALG	Signal or Auxiliary Gold Contact	-/RH	-	-/RH	LH/RH	-/RH
DINT10HHS	Signal or Auxiliary Contact	-	-	-	-	-
DSRCBSAX	Auxiliary Contact	-/RH	-	-	LH/RH	-
DSRCBSAXAL	Signal or Auxiliary Contact	-/RH	-	-	LH/RH	-
DTPBS	Panelboard Switch	-/RH	-	-/RH	-	-/RH
DINTSHT	Shunt Trip	-	-	-	-	-
DTSHT	Shunt Trip	-/RH	-	-/RH	LH/RH	-/RH
DTUVT	Undervoltage Trip	-/RH	-	-/RH	LH/RH	-/RH
DTMD	Motor Operator	LH/RH	-	-/RH	LH/RH	-/RH

## Common Add-On Devices Suitable for All MCBs and RCDs

### Function

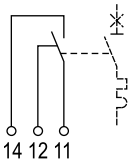
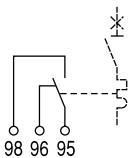
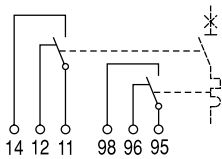
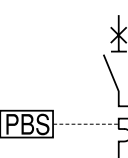
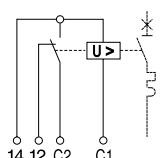
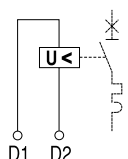
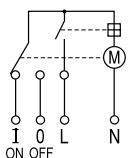
AUX		<p><b>Auxiliary Contact H</b></p> <p>For monitoring the status of the protection device (Open / Closed) independently, if it has been actuated manually or automatically.</p>
AL		<p><b>Signal or Auxiliary Contact S/H</b></p> <p>For signaling the automatic tripping of the protection devices:            Overload or short-circuit for MCBs            Earth leakage tripping for RCDs</p>
AUXAL		<p><b>Signal or Auxiliary Contact S/H + Auxiliary Contact H</b></p> <p>Two change-over contacts that include both functions as described above (S/H+H).</p>
PBS		<p><b>Panelboard Switch</b></p> <p>For opening the main device when the panel frame is removed.</p>
SHT		<p><b>Shunt Trip (Distance Tripping by Emission)</b></p> <p>For opening the device when it is fed locally or remotely.</p>
UVT		<p><b>Undervoltage Release</b></p> <p>For opening the device when the voltage goes lower than a certain value.</p>
MD		<p><b>Motor Operator</b></p> <p>Allows to switch on/off the devices from a distance.</p>



## MCBs- DIN-T6, DIN-T10, DIN-T15, DIN-TDC & DIN-T Easy-Fit

MCBs and RCBOs

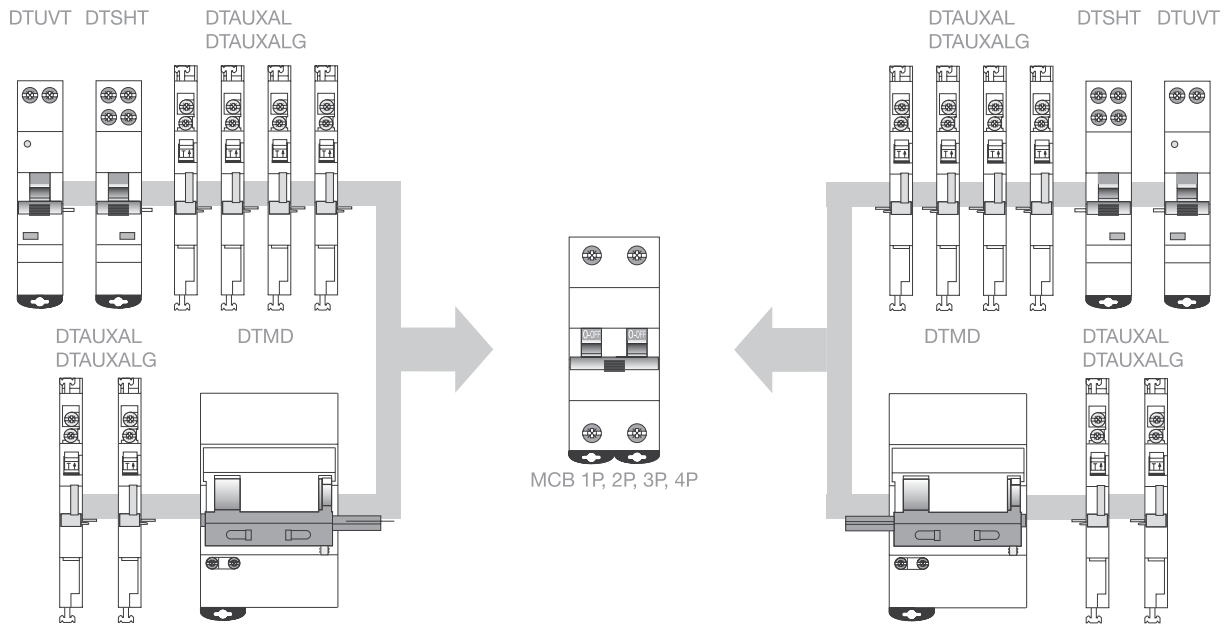

## MCBs- DIN-T6 2-in-1

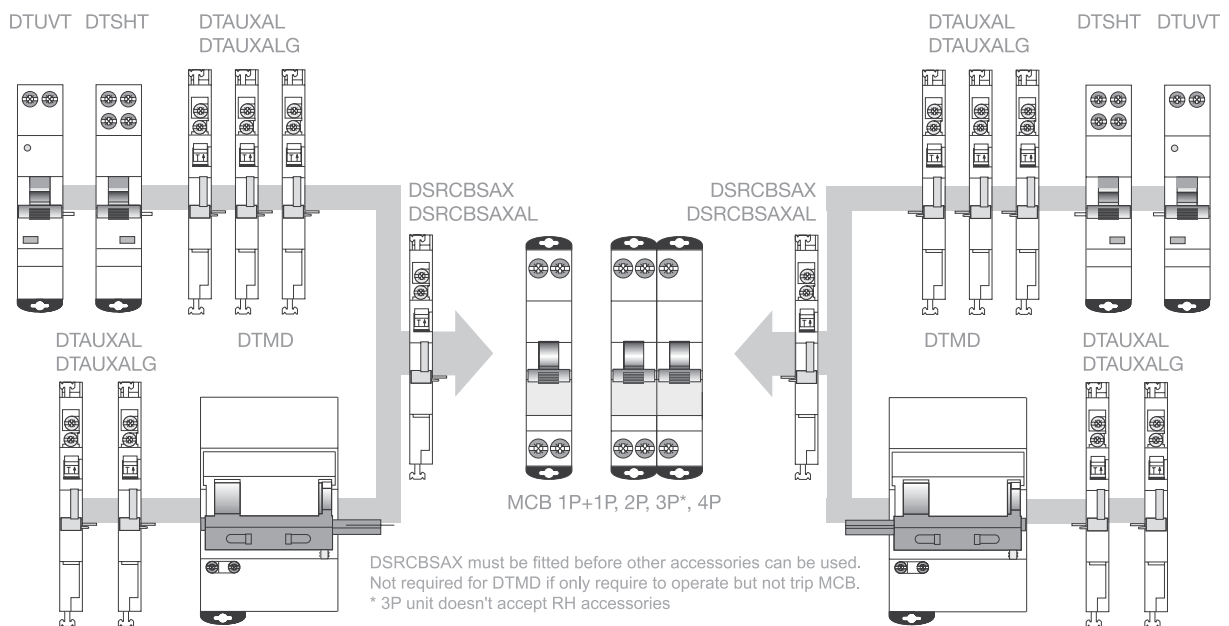

## MCBs- DIN-T10H

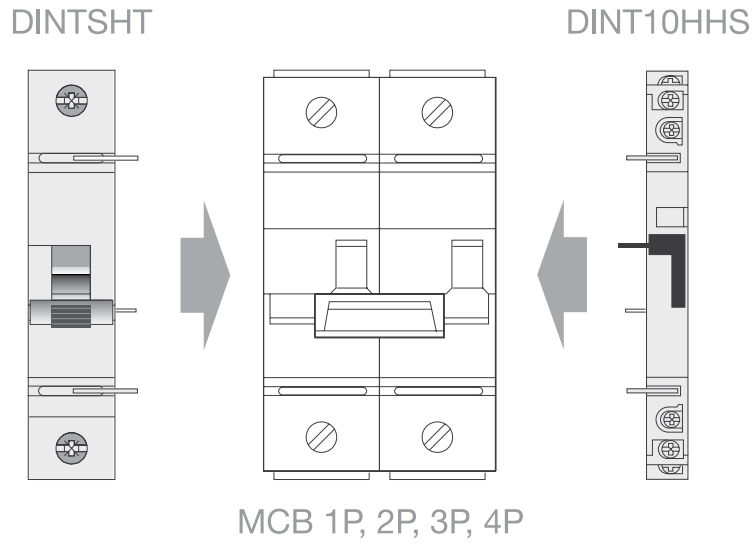

## ISOLATOR- DIN-TMS

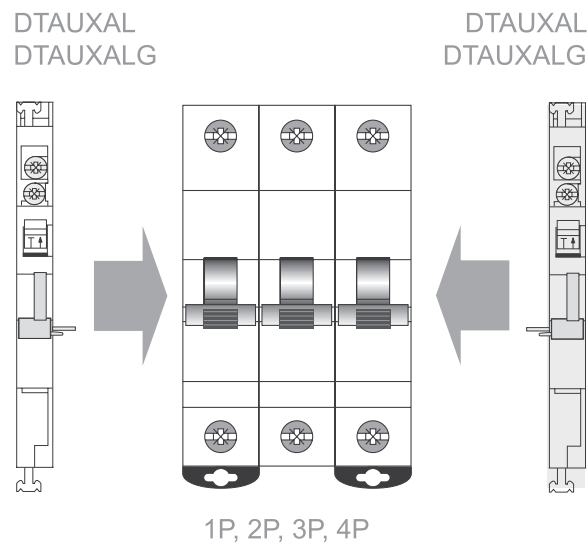



## RCCB- DSRCD

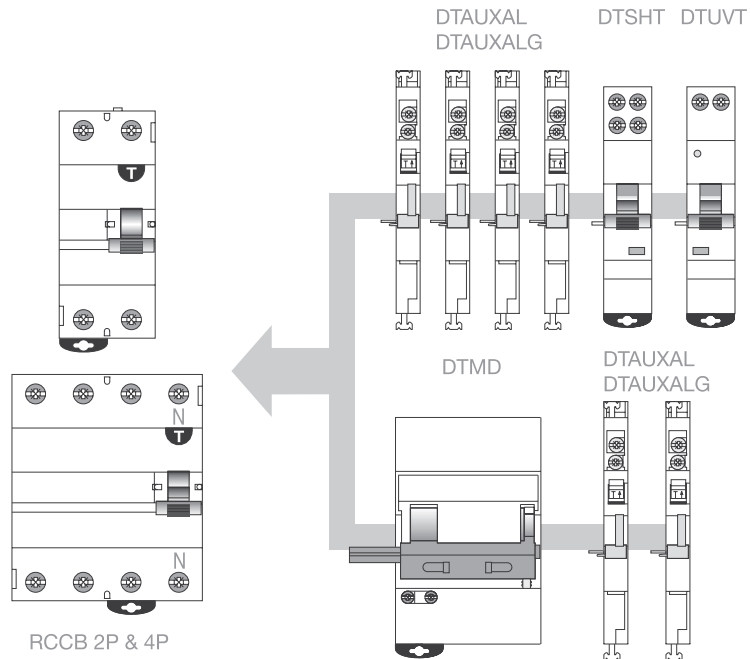

## RCBOs- DSRCBS

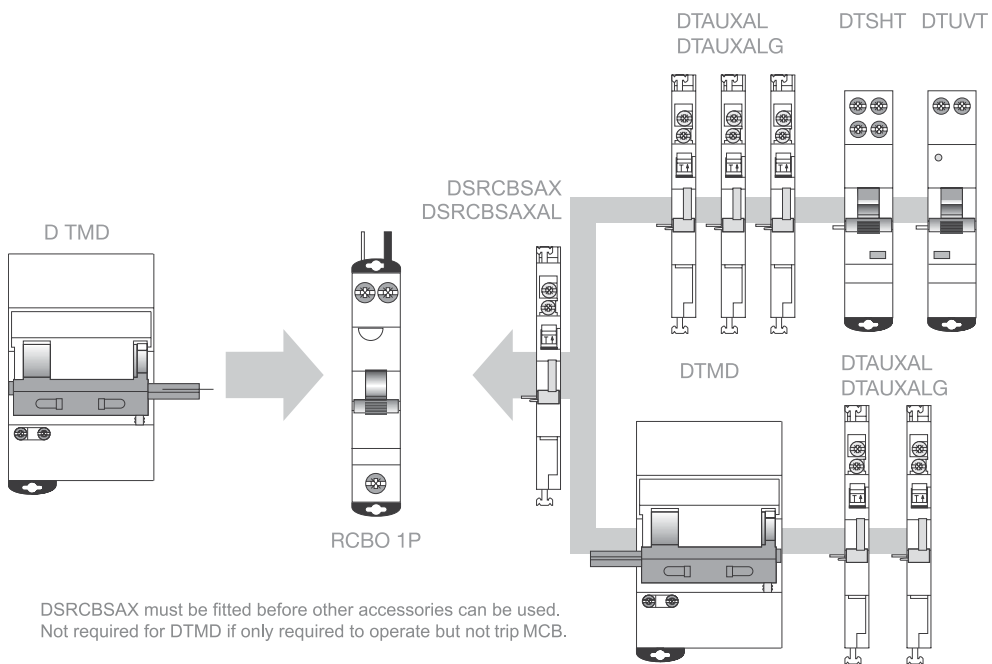

DSRCBSAX must be fitted before other accessories can be used.  
Not required for DTMD if only required to operate but not trip MCB.

## RCBOs– DSRCB

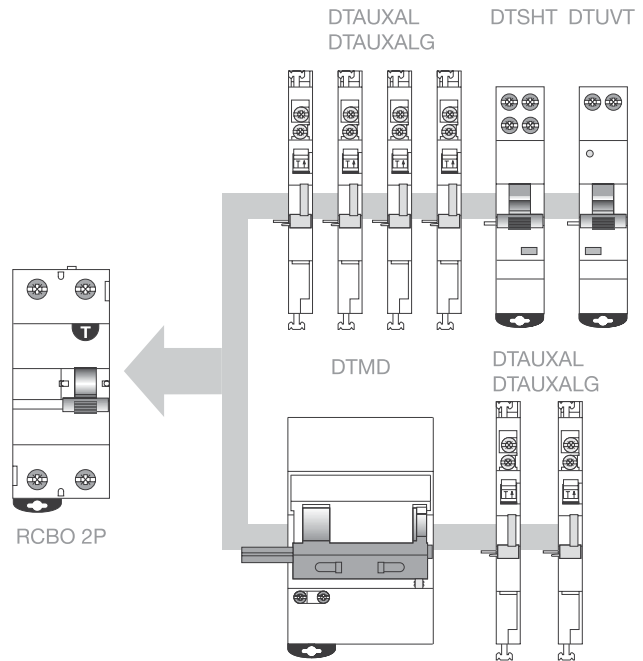

## RCBO– DSRCBxxAI

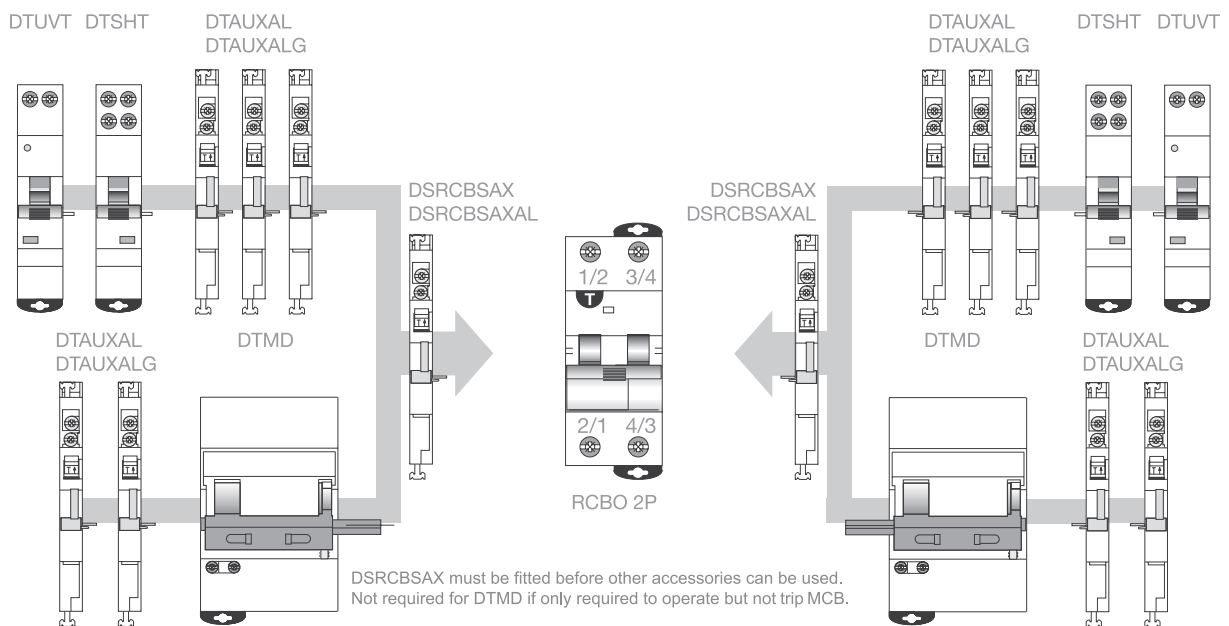

## DIN-T Add-on Modules

# DIN-T Main Switches



- ✓ IEC 60947-3
- ✓ Double break contacts
- ✓ Sealable toggle
- ✓ DIN Rail Mount
- ✓ Red Toggle
- ✓ Suits NC on GB Chassis
- ✓ Side Mount 63 - 100 A NC Chassis
- ✓ Side Mount 63 - 80 A CD Chassis



## Dimensions

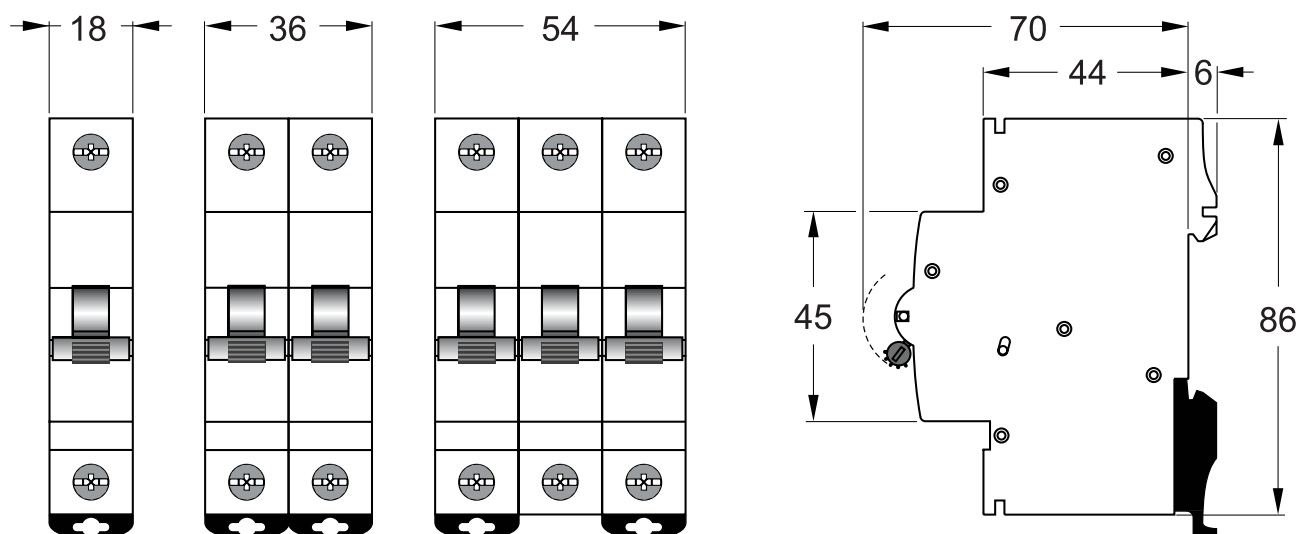



MCBs and RCBOs



Rating In (A)	No. of Poles	No. of Modules	Contacts	Catalogue No.
63	1	1		DINTMS631
	2	2		DINTMS632
	3	3		DINTMS633
80	1	1		DINTMS801
	2	2		DINTMS802
	3	3		DINTMS803
100	1	1		DINTMS1001
	2	2		DINTMS1002
	3	3		DINTMS1003



## | DIN-T Add-on Modules

# DIN-T Shunt Trip



- ✓ Coupled to left or right side of MCB
- ✓ Modular width - 18 mm
- ✓ Busbar cavity both ends
- ✓ Field assembly
- ✓ Continuously rated
- ✓ Terminals for remote indication
- ✓ Suits DIN-T6, 10, 15, DC, E6



## | Application

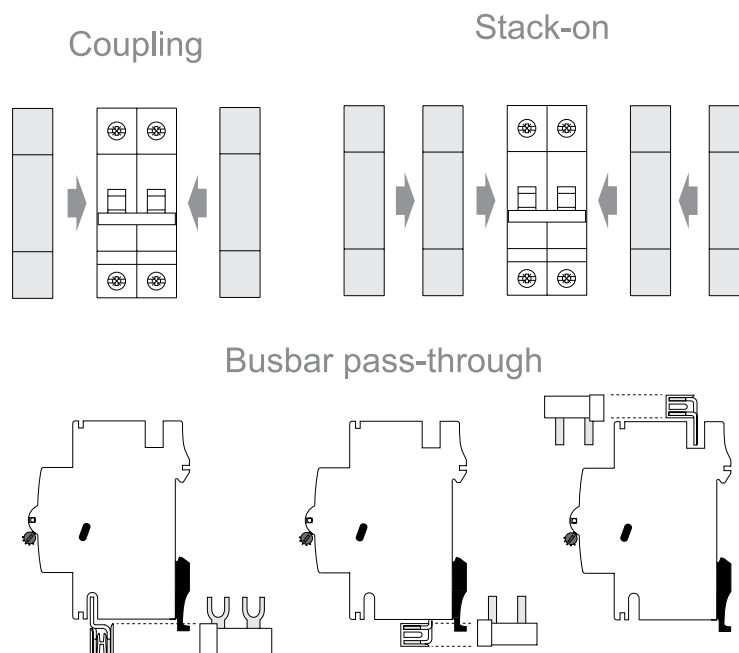

Commercial and industrial applications. Suitable for remotely tripping circuit protection devices.



## Connection

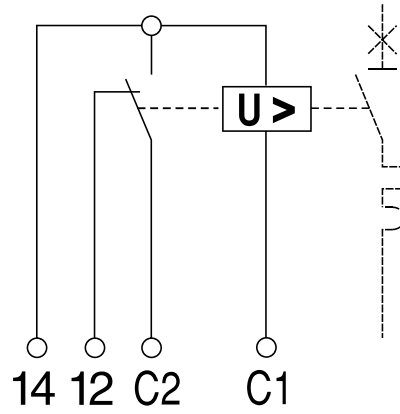

## Dimensions

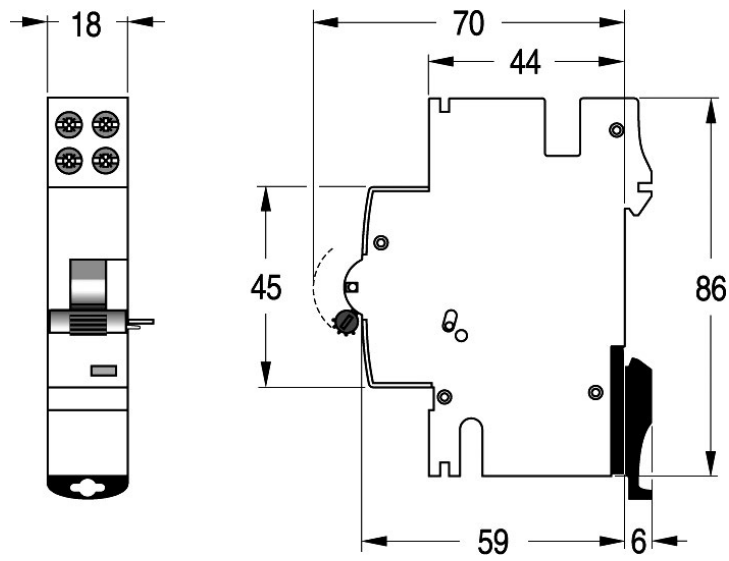

Item Description

Catalogue No.

DIN-T10H Shunt Trip 110-415 V AC & 110-125 V DC

DINTSHT110415U

DIN-T10H Shunt Trip 24-60 V AC & 24-48 V DC

DINTSHT2460U

DIN-T Shunt Trip 110-415 V AC & 110-125 V DC

DTSHT110415V

DIN-T Shunt Trip 24-60 V AC & 24-48 V DC

DTSHT2460V

## How to Couple the Shunt Trip to the Main Device

The shunt trip can easily be coupled either to the right or the left-hand side of the main device (see fig.1 and 2). The shunt trip can be coupled on the righthand side of the main device (see fig.1).

fig.1 To couple on the right-hand side

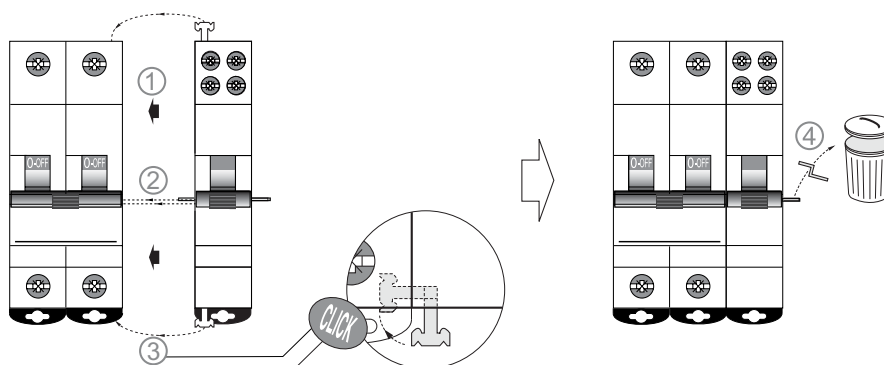

Place the shunt trip next to the main device with both toggles in OFF position.

Lock the coupling clips at the top, bottom and rear into position.

fig.2 To couple on the left-hand side: can be easily done according to the following instructions.

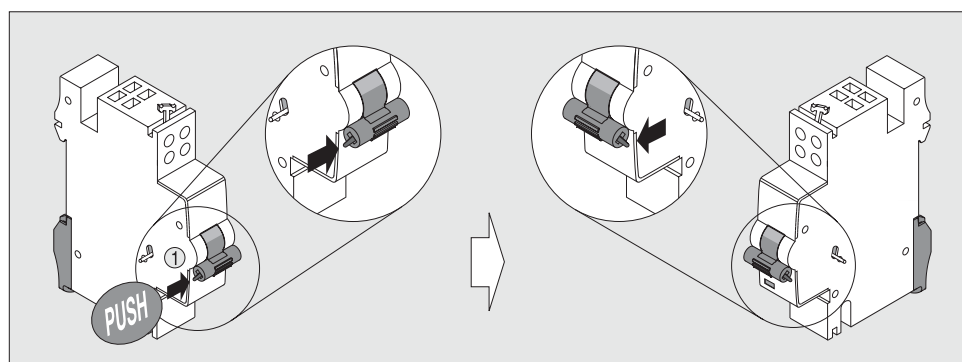

① With the help of a screwdriver, push the toggle pin to the right-hand side.

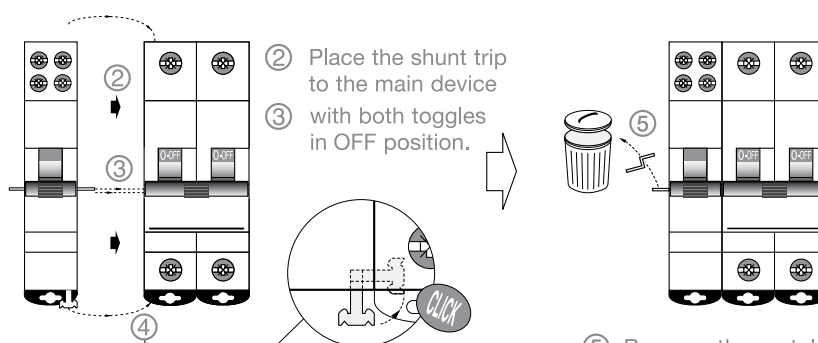

④ Lock the coupling parts in top and bottom as well as the coupling part in the back side into position.

⑤ Remove the metal pin on the left-hand side.

**Busbar connection:** the shunt trip allows the use of the PIN or FORK type busbars at the bottom terminals as well as the use of the PIN type busbars at the top terminals.

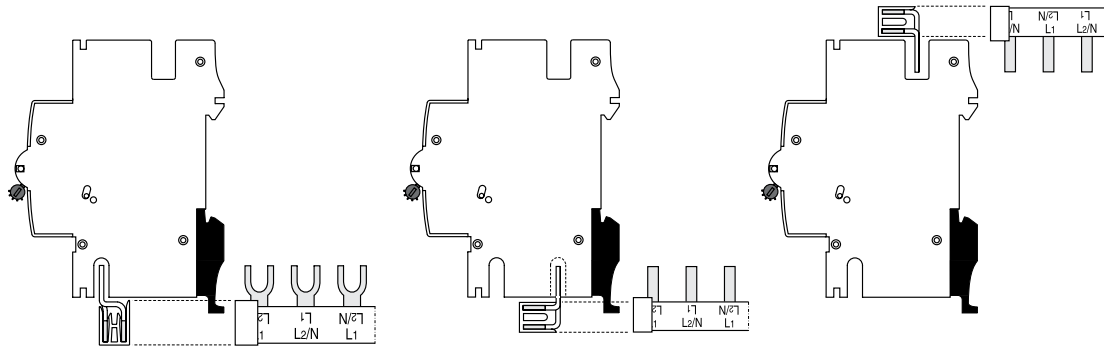

## Technical Data

		110 - 415 V Type		24 - 60 V Type	
Nominal Voltage AC	V	110 to 415		24 to 60	
Nominal Voltage DC	V	110 to 125		24 to 48	
Minimum Voltage AC / DC	V	0.85 U <sub>n</sub>		0.85 U <sub>n</sub>	
Closing Current	110 V	A	0.3	-	
	240 V	A	0.6	-	
	415 V	A	1	-	
	48 V	A	-	2	
	24 V	A	-	1	
Operating Time	110 V	ms	10		
	240 V	ms	4	-	
	415 V	ms	2	-	
	48 V	ms	-	10	
	24 V	ms	-	4	
Coil Impedance	Ω	290	24		
Electrical Endurance (Operations)			2000		2000
Terminal Capacity	Rigid Cable	mm <sup>2</sup>	1 - 2.5		1 - 2.5
	Flexible Cable	mm <sup>2</sup>	0.75 - 2.5		0.75 - 2.5
Terminal Capacity For 2 Rigid Cables		mm <sup>2</sup>	2 x 1.5		2 x 1.5
Torque		Nm	2		2

## | DIN-T Add-on Modules

# DIN-T Undervoltage Trip



- ✓ Suitable for DIN-T6, 10, 15 (Not DIN-T10H)
- ✓ Operating threshold 50 % of nominal voltage
- ✓ Time delay adjustable 0 - 300 ms
- ✓ Coupled to left or right side of MCB
- ✓ One module width (18 mm)
- ✓ Busbar cavity both ends



## | Application

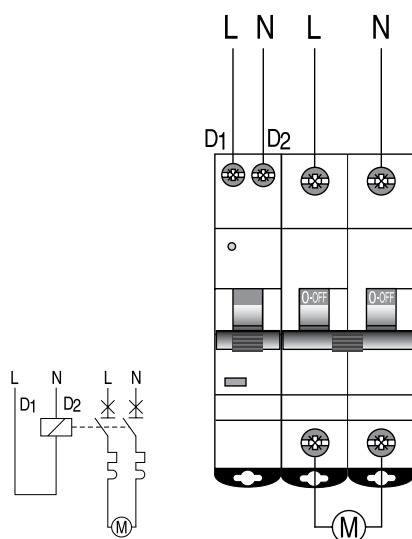

## | Connection

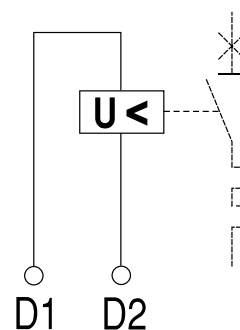

Commercial and industrial applications. Suitable for fail safe remotely tripping circuit protection devices (Emergency Stop).

## Dimensions

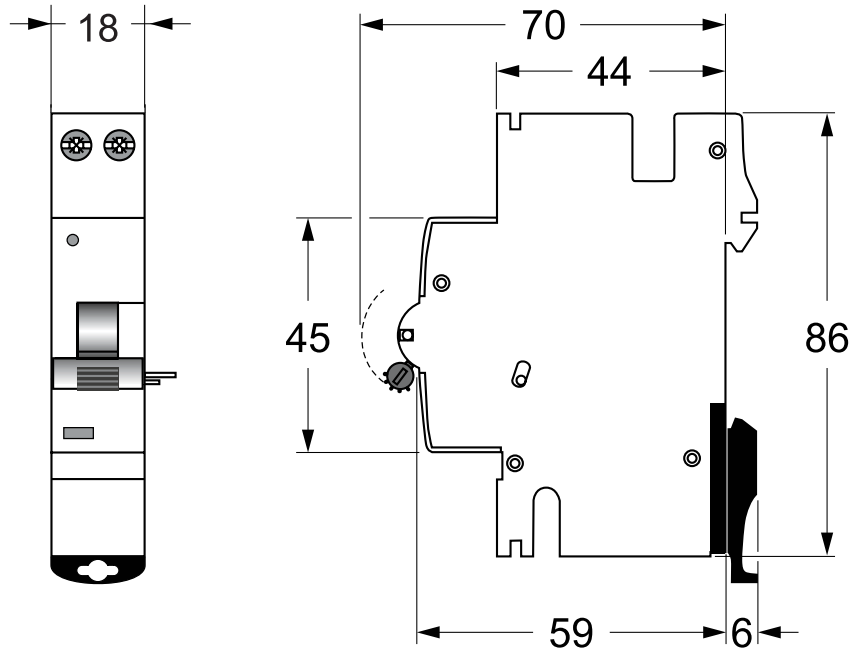

### Item Description

### Catalogue No.

DIN-T Undervoltage Trip 230 V AC

DTUVT240VAC

DIN-T Undervoltage Trip 12 V AC / DC

DTUVT12VDC

DIN-T Undervoltage Trip 24 V AC / DC

DTUVT24VDC



## How to Couple the Undervoltage Trip to the Main Device

The undervoltage release can easily be coupled either on the right or the left-hand side of the main device (see fig. 1 and fig. 2). The undervoltage release is designed to be coupled on the right-hand side of the main device (see fig. 1).

fig.1 To couple on the right-hand side

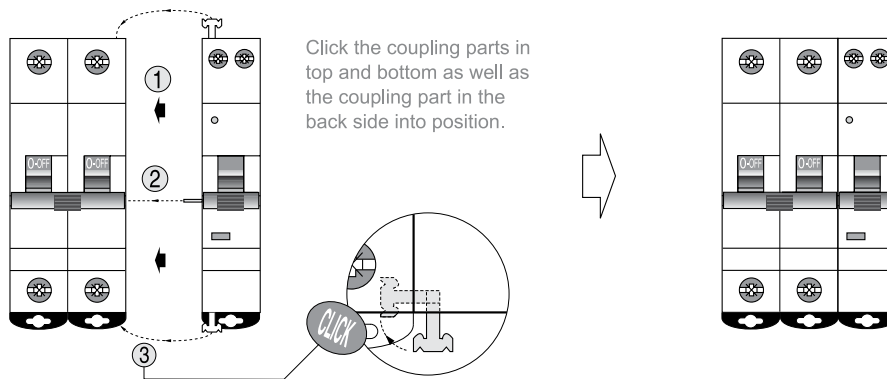

Place the undervoltage release to the main device, with both toggles in OFF position.

fig.2 To couple on the left-hand side: can be easily done according to the following instructions.

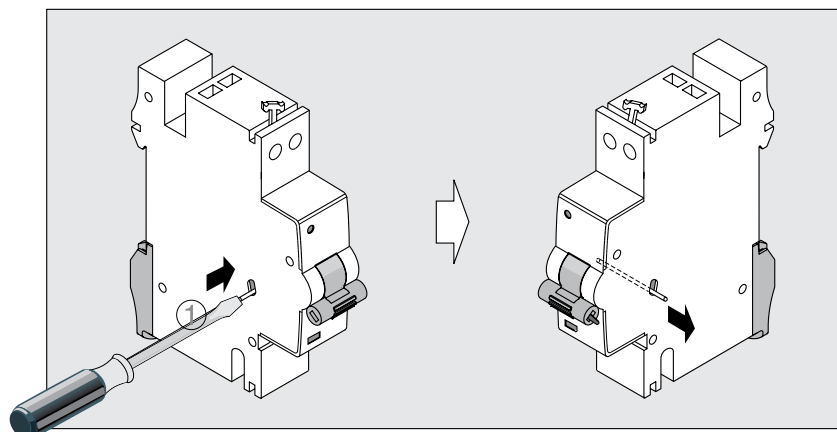

With the help of a screwdriver, push both tripping pin and toggle pin to the right-hand side.

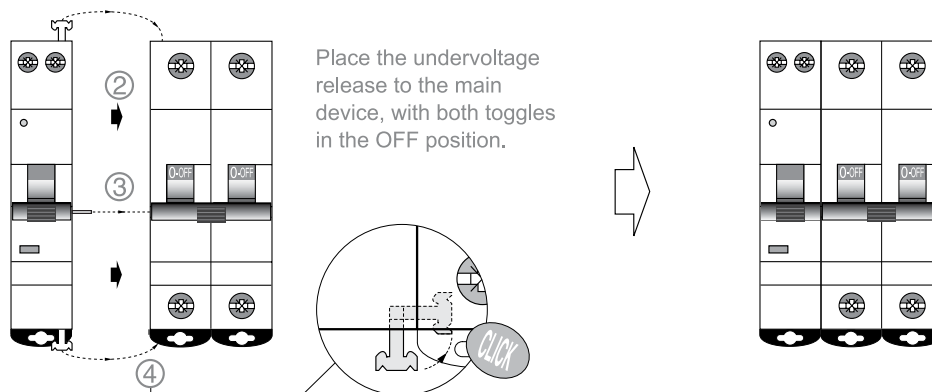

Click the coupling parts in top and bottom as well as the coupling part in the back side into position.

**Busbar passthrough:** the undervoltage release allows the passthrough of the PIN or FORK type busbars at the bottom terminals as well as the passthrough of the PIN type busbars at the top terminals.

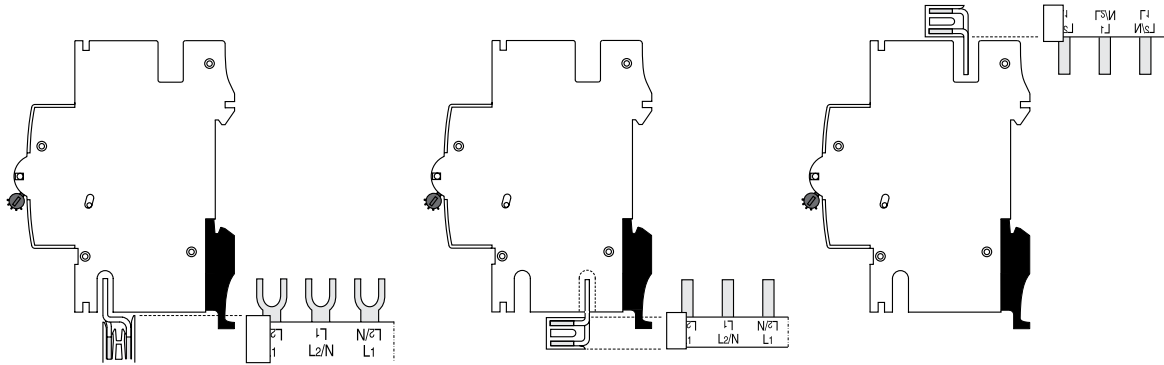

## Technical Data

		12 V	24 V	48 V	230 V
Nominal Voltage	V	12 AC / DC	24 AC / DC	48 AC / DC	230 AC
Tripping Voltage	V	0.5 U <sub>n</sub>	0.5 U <sub>n</sub>	0.5 U <sub>n</sub>	0.5 U <sub>n</sub>
		(±10 %)	(±10 %)	(±10 %)	(±10 %)
Tripping Time	ms	0 - 300	0 - 300	0 - 300	0 - 300
Power Consumption	VA	3	3	3	3
Frequency	Hz	50 - 60	50 - 60	50 - 60	50 - 60
Electrical Endurance (operations)	ops	2000	2000	2000	2000
Terminal Rigid	Capacity Cable	mm <sup>2</sup>	1 - 2.5	1 - 2.5	1 - 2.5
	Flexible Cable	mm <sup>2</sup>	0.75 - 2.5	0.75 - 2.5	0.75 - 2.5
Terminal Capacity For 2 Rigid Cables	mm <sup>2</sup>	2 x 1.5	2 x 1.5	2 x 1.5	2 x 1.5
Torque	Nm	2	2	2	2



## DIN-T Add-on Modules

# DIN-T Auxiliaries



- ✓ Auxiliary contacts are supplied as a kit for fitting to MCBs
- ✓ Field fittable. Stack up to 4 units on left or right side
- ✓ Suitable for DIN-T6, 10, 15 (Not DIN-T10H)
- ✓ DIN-T auxiliary contacts indicate main contact position of the associated main device
- ✓ Includes busbar cavity for chassis mounting
- ✓ Current rating 5 A
- ✓ Version with gold contacts available for very low current < 200 mA and voltage < 24 V applications



## Application

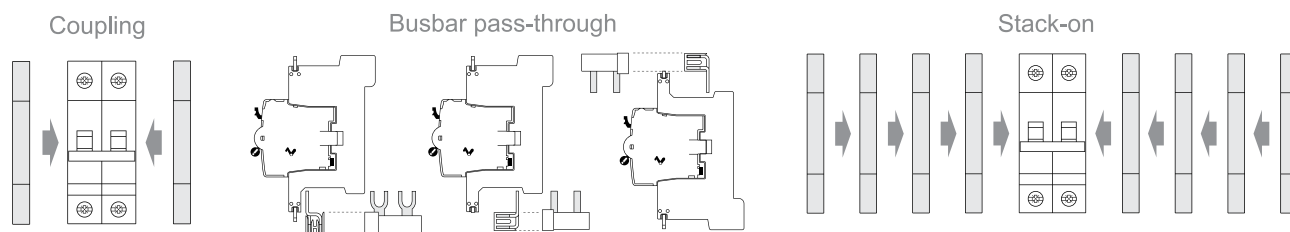

Suitable for sending remote signals indicating position of circuit protection device, switched off, switched on or tripped.

## Connection

Function H

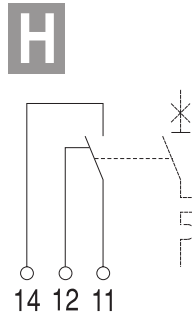

Function S

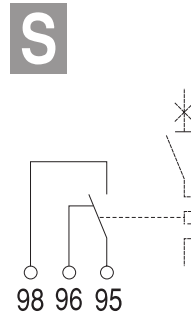

## Dimensions

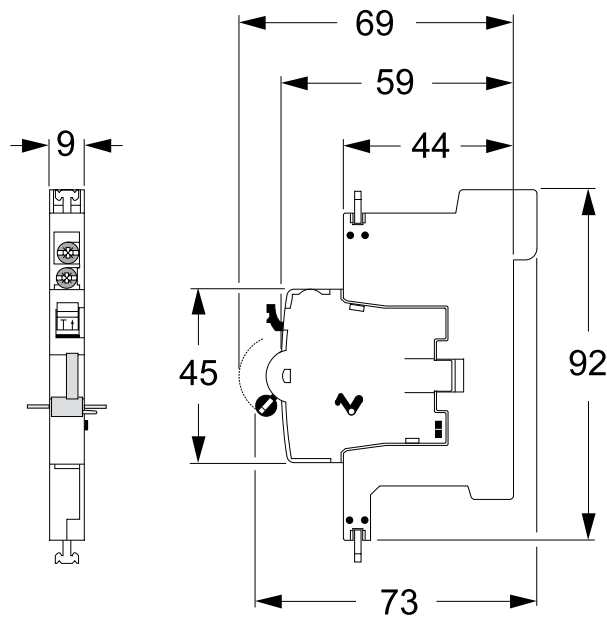

### Item Description

### Catalogue No.

Auxiliary Contact Silver Contacts; Alarm (S) or Auxiliary (H) Output - suits DIN-T

DTAUXAL

Auxiliary Contact Gold Contacts; Alarm (S) or Auxiliary (H) Output - suits DIN-T

DTAUXALG

Auxiliary Contact Silver Contacts; Alarm (S) Or Auxiliary (H) Output - suits DIN-T10H

DINT10HHS

Auxiliary Contact Silver Contacts - suits DSRCBS

DSRCBSAX

Auxiliary Contact Silver Contacts; Alarm (S) or Auxiliary (H) Output- suits DSRCBS

DSRCBSAXAL

Auxiliary Contact with Gold Contacts; provides Alarm (S) or Auxiliary (H) Output - suits DSRCBS

DSRCBSAXALG

## Function (H) Auxiliary

When function H has been selected it is possible to know the real contact position of the associated device.

### MCB ON

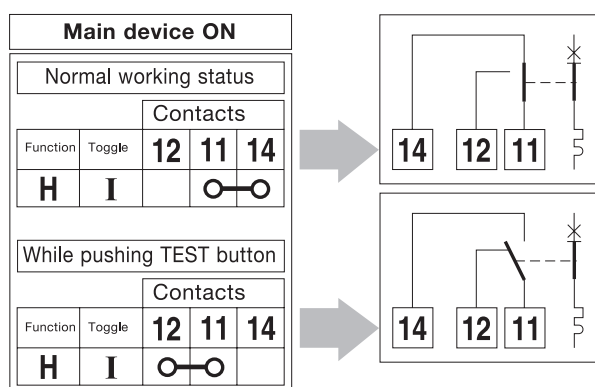

While both devices are in the ON position there is continuity between terminals 11-14. By pressing the display contact test button, the continuity changes over to terminals 11-12.

When released, the contacts changeover to the previous position 11-14.

### MCB OFF

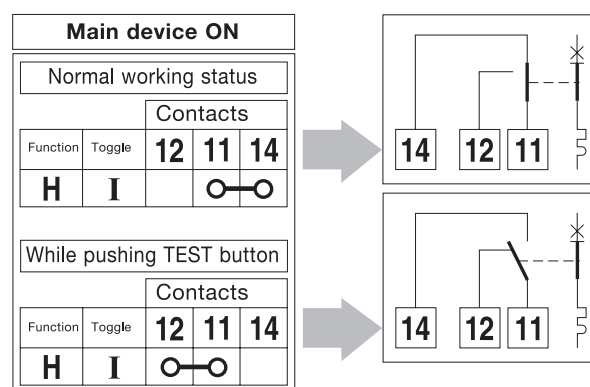

While both devices are in the OFF position there is continuity between terminals 11-12. By pressing the display contact test button, the continuity changes over to terminals 11-14.

When released, the contacts changeover to the previous position 11-12.



## Din-T Auxiliary Contacts for MCBs

### Function S (Alarm)

The function S has been selected it as possible to know if the associated device has been tripped or not. Device will not switch when associated device is manually operated.

### Test and Reset Function

#### Test Function

Allows testing of the control circuit by moving the test button up or down, without affecting the electrical status (ON/OFF) of the main device.

#### Reset Function

If the main device electrically operates (due to overload, short-circuit or earth fault current), the changeover contact switches: a red line appears on the front of the test/reset button (visible indication of electrical fault in the installation). The changeover contact can be reset by pushing the test button down without changing the electrical status (ON/OFF) of the main device.

While both devices are in the ON position there is continuity between terminals 95-98. By pressing the display contact test button, the continuity changes over to terminals 95-96. When released, the contacts changeover to the previous position, 95-98.

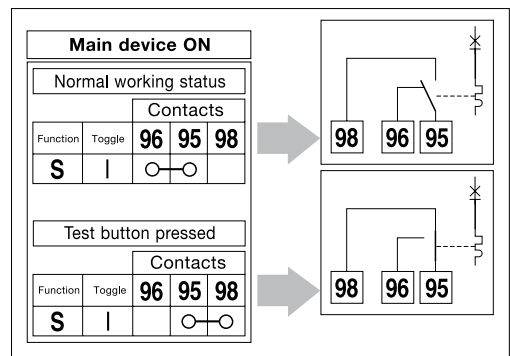
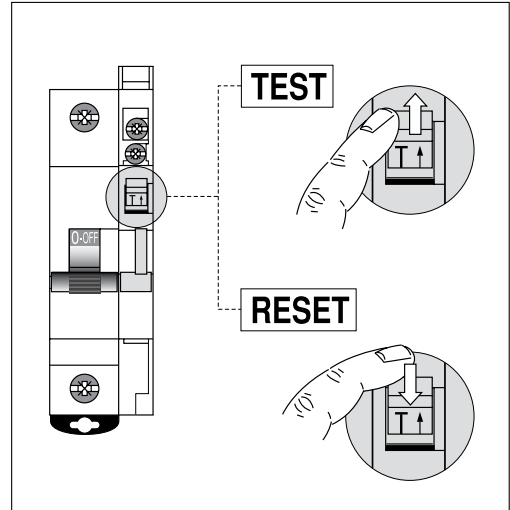

### Manual Operation

The contact position of the display contact test button has not changed. There is continuity between terminals 95-98. When pressing the display contact test button, the continuity switches over to terminals 95-96. When released, the contacts changeover to the previous position 95-98.

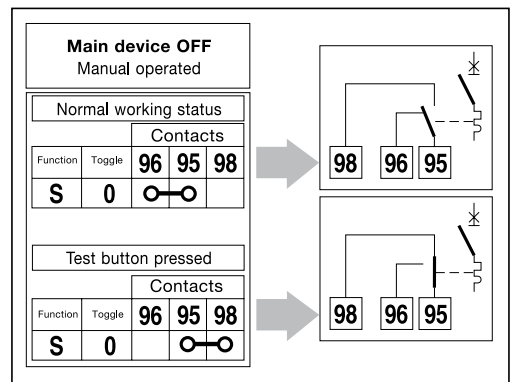

### Automatic Release

The contact position of the display contact test/reset button has changed. There is continuity between terminals 95-96. When the display contact reset button is operated the continuity switches over to terminals 95-98, and remains in that position even when the reset button is released.

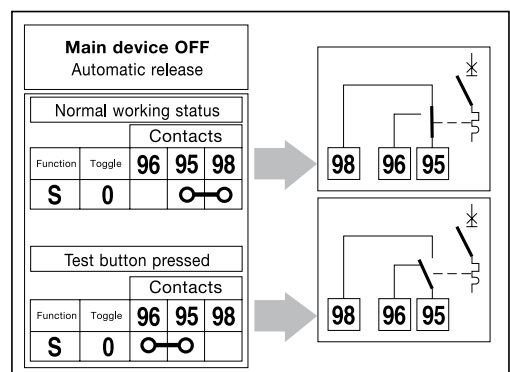



## Technical Data

### Display Contacts

				(Standard) DTAUXAL Silver	(Micro Current) DTAUXALG Gold
Maximum Current	AC 14	240 V	A	5	5
		60 V	A	1	1
	DC 12	48 V	A	2	2
		24 V	A	4	4
Minimum Application Voltage	AC / DC		V	24	12
Minimum Application Current	AC		mA	10	2
	DC		mA	200	25

### Short-Circuit Resistance

Protected By Fuses 6 A gG		A	1000	1000
Protected By MCB DIN-T 6		A	1000	1000
Electrical Endurance	(Operations)	ops	10000	10000
Terminal Capacity	Rigid Cable	mm <sup>2</sup>	1 - 2.5	1 - 2.5
	Flexible	mm <sup>2</sup>	0.75 - 2.5	0.75 - 2.5
Terminal Capacity For 2 Rigid Cables		mm <sup>2</sup>	2 x 1.5	2 x 1.5
Torque		Nm	2	2

## DIN-T Add-on Modules

# DIN-T Changeover Switch



- ✓ Standard IEC 60669-1
- ✓ Complies with IEC 408 isolating duty - has double break contacts
- ✓ Terminal protection IP 20
- ✓ Handle sealable and lockable in ON or OFF position
- ✓ Captive terminal screws with cross head

## Connection

### Changeover switch (without OFF) I-II

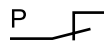
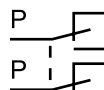
In (A)	No. of Poles	No. of Modules	Connection
32	1	1	
32	2	1	

### Changeover switch (without OFF) I-O-II

32	1	1	
32	2	1	

## Dimensions

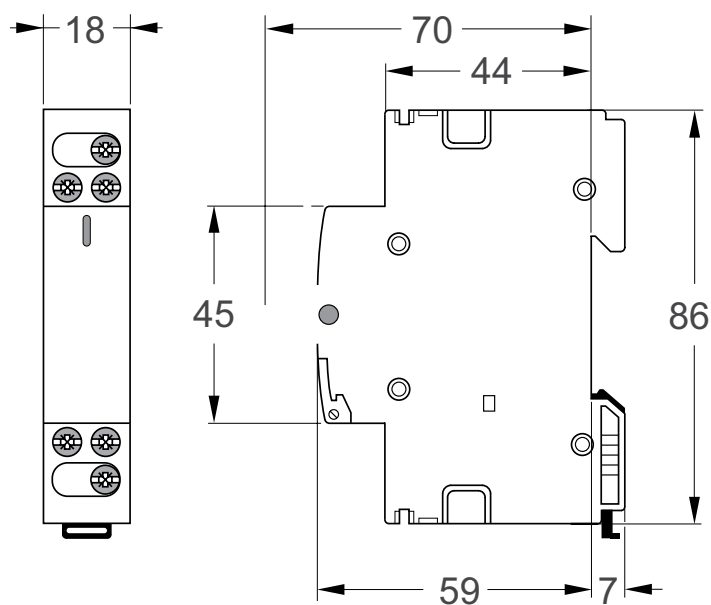

Item Description	Catalogue No.
DIN Change-Over Switch 1P 32 A without OFF Position	DTCS3212
DIN Change-Over Switch 1P 32 A with OFF Position	DTCS3213
DIN Change-Over Switch 2P 32 A without OFF Position	DTCS3222
DIN Change-Over Switch 2P 32 A with OFF Position	DTCS3223



## Technical Data

<b>Nominal Rated Current</b>	<b>32 A</b>	
<b>Usable as Mains Disconnect Switch</b>	No	
<b>Nominal Breaking Capacity at 415 V, <math>\cos \varphi = 0.95</math></b>	$1.25 \times I_n$	
<b>Nominal Breaking Capacity at 415 V, <math>\cos \varphi = 0.65</math></b>	-	
<b>Nominal Voltage Single Pole Devices</b>	240 V	
<b>Nominal Voltage Multi-Pole Devices</b>	415 V	
<b>Maximum Allowed Current During Less Than 1s</b>	-	
<b>Mechanical Service Life (Complete On-off-cycle)</b>	> 20000	
<b>Electrical Service Life, <math>\cos \varphi = 0.95</math>, <math>U_n</math> and <math>I_n</math></b>	> 5000	
<b>Short-Circuit Resistance With Upfront Fuses</b>	4.5 kA (nominal)	
<b>Short-Circuit Resistance Without Upfront Fuses</b>	3 kA (nominal)	
<b>Protection Degree</b>	IP 20	
<b>Screws</b>	Pozidrive 1	
<b>Terminal Capacity:</b>	<b>Min.</b>	1 x 1.5 mm <sup>2</sup>
	<b>Max.</b>	1 x 10 mm <sup>2</sup>



## DIN-T Add-on Modules

# DIN-T Contactors



- ✓ Standard AS/NZS 60947-4-1
- ✓ Voltage 240 / 415 V AC
- ✓ Silent operated DC magnetic drive
- ✓ Integrated surge suppression
- ✓ Switch position indicator
- ✓ Increased switching capacity and endurance
- ✓ DIN rail mount
- ✓ 20 A AC Magnetic system
- ✓ 24, 40, 63 A DC Magnetic system



## Dimensions

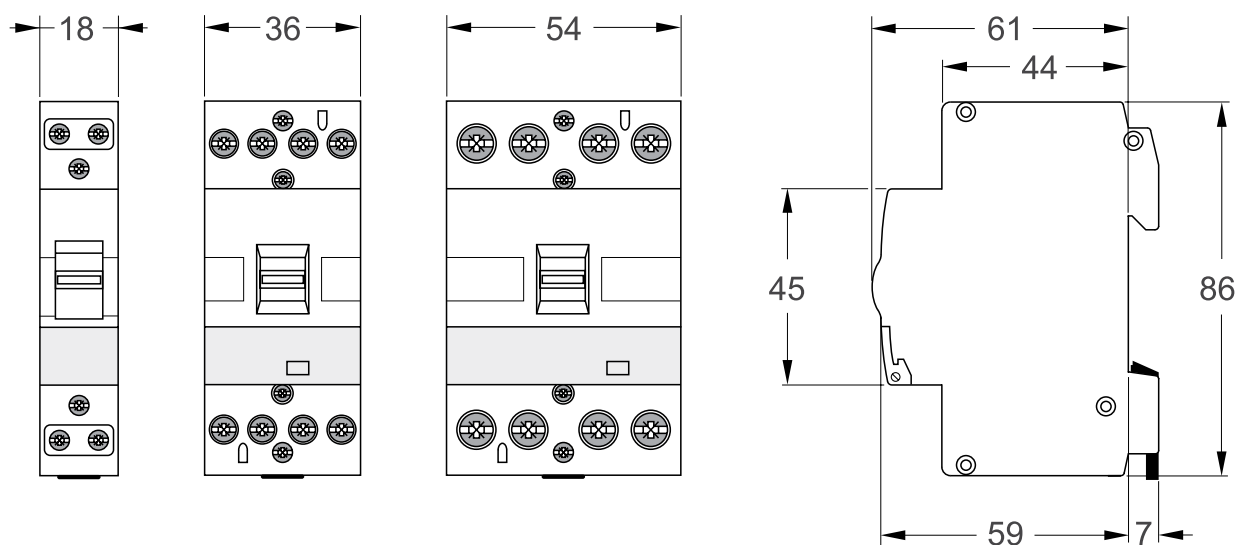



I <sub>th</sub> @40 °C (A)	Contacts	Coil Voltage (V AC / V DC)	W (mm)	AC-7a @240 V (A / kW)	AC-7b @240 V (A / kW)	Catalogue No.
20	2 NC	240 V AC	18	20 A / 4 kW	9 A / 1.3 kW	DTC2002240
20	1 NO + 1 NC	240 V AC	18	20 A / 4 kW	9 A / 1.3 kW	DTC2011240
20	2 NO	24 V AC	18	20 A / 4 kW	9 A / 1.3 kW	DTC202024
20	2 NO	240 V AC	18	20 A / 4 kW	9 A / 1.3 kW	DTC2020240
24	4 NC	240 V AC / 240 V XC	36	24 A / 5.3 kW	6 A / 1.3 kW	DTC2404240
24	4 NO	12 V AC / 12 V XC	36	24 A / 5.3 kW	9 A / 1.3 kW	DTC244012
24	4 NO	24 V AC / 24 V XC	36	24 A / 5.3 kW	9 A / 1.3 kW	DTC244024
24	4 NO	240 V AC / 240 V XC	36	24 A / 5.3 kW	9 A / 1.3 kW	DTC2440240
40	4 NO	24 V AC / 24 V XC	54	40 A / 8.7 kW	22 A / 3.7 kW	DTC404024
40	4 NO	240 V AC / 240 V XC	54	40 A / 8.7 kW	22 A / 3.7 kW	DTC4040240
63	4 NO	24 V AC / 24 V XC	54	63 A / 13.3 kW	30 A / 5 kW	DTC634024
63	4 NO	240 V AC / 240 V XC	54	63 A / 13.3 kW	30 A / 5 kW	DTC6340240

## Din-T Contactors DTC

Type	DTC20...	DTC24...	DTC40...	DTC63...
Contact Configuration	1 N/O - 1 N/C or 2 N/C	4 N/O or 4 N/C	4 N/O	
Rated Insulation Voltage	400 V	500 V	500 V	500 V

### AC 1/ AC 7a Switching of Heaters

Rated Operational Current $I_e$ <sup>1)</sup>	20 A	24 A	40 A	63 A
Rated Output AC 1	240 V 1 $\emptyset$	4 kW	5.3 kW	13.3 kW
	415 V 3 $\emptyset$	-	16 kW	40 kW

### AC 3/AC 7b Switching of Motors

Rated Operational Current $I_e$ <sup>1)</sup> (AC 3)	9 A	9 A 6 A	22 A	30 A
Rated Output AC 3	240 V 1 $\emptyset$	1.3 kW	1.3 kW	5 kW
	415 V 3 $\emptyset$	-	4 kW	11 kW

### AC 5a Switching of Electric Discharge Lamp Controls (Fluorescent Lamps Uncompensated)

Rated Operational current $I_e$ <sup>1)</sup>	8 A	10 A	30 A	44 A
---	-----	------	------	------

### AC 5b Switching of Incandescent Lamps

Rated operational current $I_e$ <sup>1)</sup>	6 A	7 A	15 A	22 A
---	-----	-----	------	------

### Switching of DC (with N/O contacts)

Rated Operating Voltage $U_e$		DC 1 (L/R < 1ms) <sup>2)</sup>			DC 3 (L/R < 2ms) <sup>2)</sup>		
		1 pole	2 pole	3 pole	1 pole	2 pole	3 pole
DC 24	24 V DC	24.0 A	24.0 A	24.0 A	16.0 A	24.0 A	24.0 A
	220 V DC	0.9 A	4.5 A	13.0 A	0.2 A	1.0 A	4.0 A
DC 40	24 V DC	40.0 A	40.0 A	40.0 A	19.0 A	40.0 A	40.0 A
	220 V DC	1.0 A	5.0 A	15.0 A	0.3 A	1.1 A	4.5 A
DC 63	24 V DC	50.0 A	63.0 A	63.0 A	21.0 A	44.0 A	63.0 A
	110 V DC	9.0 A	19.0 A	33.0 A	8.0 A	8.0 A	8.0 A
	220 V DC	1.1 A	5.5 A	17.0 A	0.3 A	1.2 A	5.0 A

### Switching of DC (with N/O contacts)

Rated Operating Voltage $U_e$		DC 1 (L/R < 1ms) <sup>2)</sup>			DC 3 (L/R < 2ms) <sup>2)</sup>		
		1 pole	2 pole	3 pole	1 pole	2 pole	3 pole
DC 24	24 V DC	14.5 A	24.0 A	24.0 A	6.3 A	11.0 A	19.0 A
	220 V DC	0.2 A	1.4 A	3.8 A	0.1 A	0.6 A	1.6 A

**Notes** <sup>1)</sup> When parallel switching of 2 current paths the rated current  $I_e$  will be multiplied by 1.6.

<sup>2)</sup> 2 and 3 poles connected in series. If several contactors are mounted beside each other and the operating time is greater than one hour, leave a 1/2 module distance between every 3rd contactor. (Not applicable for ambient temperatures <40 °C and for type DTC20)

Type	DTC20	DTC24	DTC40	DTC63
------	-------	-------	-------	-------

### Characteristics of the Magnet System

Control Voltage Range		0.85 ... 110 % x Un			
Operating Temperature		-25-155 %			
Operating Frequency		60 HZ	OC, 40-450 HZ	OC, 40-450 HZ	OC, 40-450 HZ
Rated Consumption of Magnetic Coil at U <sub>c</sub> = 240 V	Pull-in	8 VA	4 VA	8 VA	6.5 VA
		5 W	4 W	5 W	6.5 W
	Holding	3.2 VA	4 VA	5 VA	4.2 VA
		1.2 W	4 W	5 W	4.2 W
Switching-On Delay		9 - 12 ms	< 40 ms	< 40 ms	< 40 ms
Switching-Off Delay		10 - 12 ms	< 40 ms	< 40 ms	< 40 ms
Definite Switching-Off Between		20 to 75 % U <sub>c</sub>		10 to 75 % U <sub>c</sub>	
Ohmic Loss per Current Path at I <sub>th</sub> and AC 1		1 W	1.5 W	3 W	6 W
Connections	Main Leads	1 x 10 mm <sup>2</sup> / 2 x 4 mm <sup>2</sup>		1 x 25 mm <sup>2</sup> / 2 x 10 mm <sup>2</sup>	
	Coil	1 x 4 mm <sup>2</sup> / 2 x 2.5 mm <sup>2</sup>			

### Endurance and Mechanical Switching

Endurance	Mechanical	1 x 10 <sup>6</sup>	1 x 10 <sup>6</sup>	1 x 10 <sup>6</sup>	1 x 10 <sup>6</sup>	
	Electrical	at AC 1 / AC 7a	150 000	150 000	150 000	150 000
		at AC 3 / AC 7b	150 000	500 000	170 000	240 000
Maximum Switching	AC 1 / AC 7a	300 operations/h				
	AC 3 / AC 7b	600 operations/h				
Rated Operating Frequency		50 or 60 Hz	DC, 40 up to 450 Hz			
Switching-On Capacity	Cos $\phi$ 0.65 at 380 - 400 V 3 $\phi$	-	90 A	176 A	300 A	
I <sub>eff</sub> (IEC 60947-4-1)	Cos $\phi$ 0.95 at 220 - 230 V 1 $\phi$	100 A	-	-	-	
Switching-On Capacity	Cos $\phi$ 0.65 at 380 - 400 V 3 $\phi$	-	72 A	176 A	240 A	
I <sub>eff</sub> (IEC 60947-4-1)	Cos $\phi$ 0.95 at 220 - 230 V 1 $\phi$	80 A	-	-	-	
Short Time Circuit Max. 10s at Ambient Temp of < 40°C in Free Air, from Cold Start		76 A	68 A	176 A	240 A	



## Switching for Lamp Load

Lamp Type	Lamp Data		Permitted Number of Lamps Per Phase (230 V, 50 Hz) for Contactor Type			Capacitor	
	Watt	In (A)	DTC 20	DTC 24	DTC 40	DTC 63	( $\mu$ F)
Incandescent Lamps	60	0.26	21	25	54	83	
	100	0.43	13	15	32	50	
	200	0.87	7	7	16	25	
	300	1.3	4	5	11	16	
	500	2.17	3	3	6	10	
	1000	4.35	1	1	3	5	
Fluorescent Lamps	<b>Uncompensated and Series Compensation</b>						
	15	0.35	25	30	100	155	
	20	0.37	22	26	85	140	
	40	0.43	17	20	65	105	
	42	0.54	13	16	52	85	
	65	0.67	10	12	40	60	
	115	1.5	4	5	18	28	
	140	1.5	4	5	18	28	
	<b>Two Lamp Circuit</b>						
	2 x 20	2 x 0.13	2 x 22	2 x 26	2 x 85	2 x 140	
	2 x 40	2 x 0.22	2 x 17	2 x 20	2 x 65	2 x 105	
	2 x 42	2 x 0.24	2 x 13	2 x 16	2 x 52	2 x 85	
	2 x 65	2 x 0.34	2 x 10	2 x 12	2 x 40	2 x 60	
	2 x 115	2 x 0.65	2 x 4	2 x 5	2 x 18	2 x 28	
	2 x 140	2 x 0.75	2 x 4	2 x 5	2 x 18	2 x 28	
	<b>Parallel Compensation</b>						
	15	0.11	6	8	15	67	4.5
	20	0.13	5	7	14	60	5
	40	0.22	6	8	15	67	4.5
	42	0.24	4	6	12	50	6
	65	0.34	4	5	10	43	7
	115	0.65	1	2	4	17	18
	140	0.75	1	2	4	17	18

## DC-1 / DC-3 Switching DC with N/O Contacts

Type	Rated Operational Voltage $U_e$ (A)	DC-1 ( $L/R \leq 1\text{ms}$ )			DC-3 ( $L/R \leq 2\text{ms}$ )		
		1 Current Path (A)	2 Current Path Series (A)	3 Current Path Series (A)	1 Current Path (A)	2 Current Path Series (A)	3 Current Path Series (A)
<b>CTX24</b>	24 VDC	24	24	24	16	24	24
	48 VDC	21	24	24	8	18	24
	60 VDC	17	24	24	4	14	24
	110 VDC	7	16	24	16	6.5	16
	220 VDC	0.9	4.5	13	0.2	1	4
<b>CTX24</b>	24 VDC	40	40	40	19	40	40
	48 VDC	23	40	40	10	20	40
	60 VDC	18	32	40	5	16	34
	110 VDC	8	17	30	1.8	7	18
	220 VDC	1	5	15	0.3	1.1	4.5
<b>CTX24</b>	24 VDC	50	63	63	21	44	63
	48 VDC	25	43	63	11	22	47
	60 VDC	20	35	60	5.5	18	38
	110 VDC	9	19	33	2	8	21
	220 VDC	1.1	5.5	17	0.3	1.2	5

## Switching for Lamp Load

Lamp Type	Lamp Data		Permitted Number of Lamps per Phase (230 V, 50 Hz) for Contactor Type			Capacitor	
	Watt	In (A)	DTC 20	DTC 24	DTC 40	DTC 63	(µF)
High Pressure Mercury Vapor Lamps (e.g. HQL, HPL)	<b>Uncompensated</b>						
	50	0.61	12	14	36	50	
	80	0.8	7	10	27	38	
	125	1.5	5	7	19	26	
	250	2.15	3	4	10	14	
	400	3.25	1	2	7	10	
	700	5.4	-	1	4	6	
	100	7.5	-	1	3	4	
	2000 / 400 V	8	-	1	3	4	
	<b>Parallel Compensation</b>						
	50	0.28	4	5	10	43	7
	80	0.41	3	4	8	37	8
	125	0.65	2	3	6	26	10
	250	1.22	1	2	3	15	18
400	1.62	-	1	3	10	25	
700	3.45	-	-	1	5	45	
1000	4.8	-	-	1	4	60	
2000 / 400 V	5.45	-	1	2	2	35	
Lamps With Electronic Power Supply Units	<b>Permitted Number of Electropower Supply Units Per Phase</b>						
	1 x 18	2 x 0.13	2 x 22	2 x 26	2 x 85	2 x 140	
	2 x 18	2 x 0.22	2 x 17	2 x 20	2 x 65	2 x 105	
	1 x 36	2 x 0.24	2 x 13	2 x 16	2 x 52	2 x 85	
	2 x 36	w2 x 0.34	2 x 10	2 x 12	2 x 40	2 x 60	
	1 x 58	2 x 0.65	2 x 4	2 x 5	2 x 18	2 x 28	
	2 x 58	2 x 0.75	2 x 4	2 x 5	2 x 18	2 x 28	
Metal-Halogen Lamps (e.g. HQI HPI)	<b>Uncompensated</b>						
	35	0.53	-	10	28	38	-
	70	1	-	5	14	20	-
	150	1.8	-	3	8	11	-
	250	3	-	2	5	7	-
	400	3.5	-	1	4	6	-
	1000	9.5	-	-	1	2	-
	2000	16.5	-	-	1	1	-
	2000 / 400V	10.5	-	-	2	2	-
	3500 / 400V	18	-	-	1	1	-
	<b>Parallel Compensation</b>						
	35	0.25	-	5	11	30	6
	70	0.45	-	3	5	18	14
	150	0.75	-	1	3	9	20
	250	1.5	-	1	2	7	33
	400	2.5	-	1	2	6	35
	1000	5.8	-	-	-	2	95
	2000	11.5	-	-	-	1	148
2000 / 400V	6.6	-	-	1	2	58	
3500 / 400V	11.6	-	-	-	1	100	

## Switching for Lamp Load cont.

Lamp Type	Lamp Data		Permitted Number of Lamps per Phase (230 V, 50 Hz) for Contactor Type			Capacitor	
	Watt	In (A)	DTC 20	DTC 24	DTC 40	DTC 63	( $\mu$ F)
Low Pressure Sodium Vapor Lamps	Uncompensated						
	35	1.5	5	8	22	30	
	55	1.5	5	8	22	30	
	90	2.4	3	5	13	19	
	135	3.5	2	3	10	13	
	150	3.3	2	3	10	14	
	180	3.3	2	3	10	14	
	200	2.3	3	5	14	20	
	Parallel Compensation						
	5	0.31	-	1	4	15	20
	55	0.42	-	1	4	15	20
	90	0.63	-	1	3	10	30
	135	0.96	-	-	2	7	45
	150	1	-	-	2	8	40
	180	1.16	-	-	2	8	40
	200	1.32	-	1	3	12	25
High Pressure Parallel Compensation	Uncompensated						
	150	1.8	-	4	15	20	
	250	3	-	3	9	15	
	330	3.7	-	2	8	10	
	400	4.7	-	1	6	8	
	1000	10.3	-	-	3	4	
	Parallel Compensation						
	150	0.83	-	1	3	15	20
	250	1.5	-	1	2	9	33
	330	2	-	-	2	7	40
	400	2.4	-	-	1	6	48
	1000	6.3	-	-	-	2	106
		Transformer Data		Permitted Number of Lamps per Phase (230 V, 50 Hz) for Contactor Type			
Lamp Type	Watt						
Transformers for Halogen Low Voltage Lamps	20		40	52	110	174	
	50		20	24	50	80	
	75		13	16	35	54	
	100		10	12	27	43	
	150		7	9	19	29	
	200		5	6	14	23	
	300		3	4	9	14	



## Endurance

In general, the guaranteed number of operations at nominal load in AC 1 is called the electrical service life. The DIN-T contactors all have an electrical service life of 150000 operations (Note: 1 cycle = N/O → N/C → N/O = 2 operations).

However, if the load of the contactor is less than its nominal load, the erosion of the contacts will be less and as a consequence, the electrical service life will increase.

The graphs below show the relation between the number of operations and the maximum load allowed to obtain this life expectancy.

### Endurance Curve (Operations vs. Switching-off Current)

AC 1 / 400 V 3 for 24, 40, 63 A types  
AC 1 / 230 V 1 for 20 A type

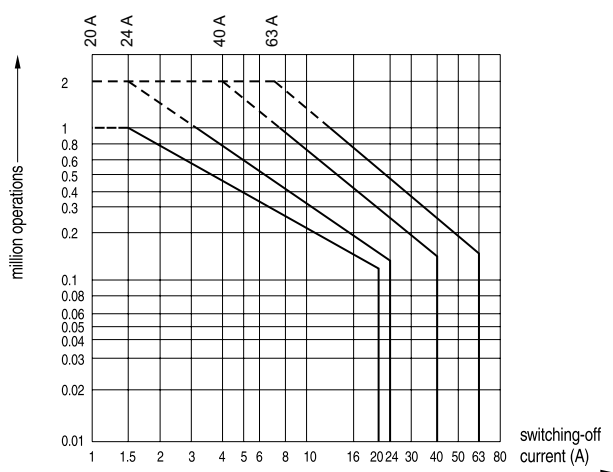

### Endurance Curve (Operations vs. Switching-off Current [kW])

AC 3 / 400 V 3 for 24, 40, 63 A types  
AC 3 / 230 V 1 for 20 A type

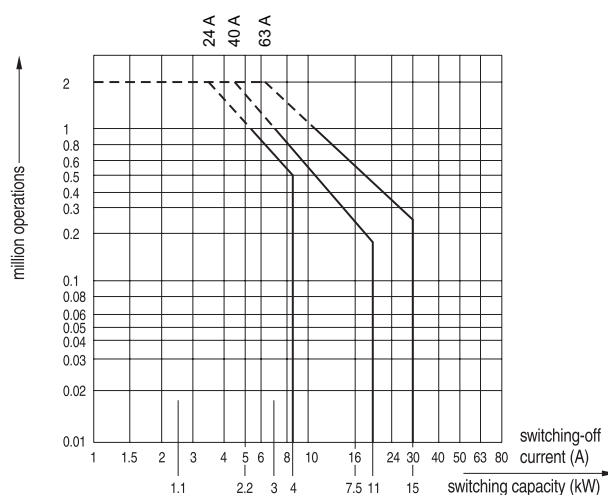

## Example

An electrical heater (4.4 kW, 230 V, single phase) is used for 200 days per year. On average, the thermostat switches 50 times a day on and off (= 100 operations).

The total number of operations per year is 20000 (200 days x 100 operations/day).

The current this heater draws is roughly 20 A.

In this case,

- a 20 A contactor will operate for 7.5 years (150000 / 20000),
- a 24 A contactor will operate for 9 years (180000 / 20000),
- a 40 A contactor will operate for 15 years (300000 / 20000),
- a 63 A contactor will operate for 27 years (540000 / 20000).



## General Remarks

- Using contactors at low voltage, and especially when several devices can be operated simultaneously, ultimate care should be taken to the correct dimensioning of the step-down transformer.
- When several adjacent contactors are continuously energised (1 hour and more), the heat dissipation could influence the correct operation in a negative way. If several contactors are mounted beside each other and the operating time is greater than 1 hour, leave a 1/2 module distance between every 3rd contactor. (Not applicable for ambient temperature lower than 40 °C or for 20 A types).

## Features

- Contactors all have a silent operation and therefore are preferably equipped with a DC-coil
- An internal bridge rectifier allows the contactor to be used on AC (from 40 to 450 Hz) as well as on DC (except for the 20 A contactor)
- The capacity of the load-terminals is from 1.5 to 10 mm<sup>2</sup>
- The capacity of the control-terminals is from 0.5 to 4 mm<sup>2</sup>
- The contactors are equipped with a flag which indicates the position of the coil (contacts)
- The protection-degree of the contactor is IP 20
- The devices are modular and DIN-rail mountable
- Auxiliary contacts as well as spacers for heat dissipation are available
- The power-supply voltage is allowed to vary in the range of 106 % x Un ... 80 % x Un without influencing the correct operation of the device
- Day-Night contactors are available; these contactors have a 0 - Auto - 1 switch for manual operation. This switch cannot be blocked in the 1 - position

## DIN-T Add-on Modules

# DIN Contactors



- ✓ Standard AS/NZS 60947.4.1
- ✓ Voltage 240 / 415 V AC
- ✓ Switch Position number
- ✓ DIN rail mount

I <sub>th</sub> @40°C (A)	Contacts	Coil Voltage (V AC / V DC)	W (mm)	AC-7a @240V (A / kW)	AC-7b @240V (A / kW)	Catalogue No.
20	2 NO	24 V AC	51	20 A / 4 kW	7 A / 1.2 kW	DTC202024L
20	2 NO	240 V AC	18	20 A / 4 kW	7 A / 1.2 kW	DTC2020240L
25	4 NO	12 V AC	36	25 A / 5.4 kW	8.5 A / 1.5 kW	DTC254012L
25	4 NO	240 V AC	36	25 A / 5.4 kW	8.5 A / 1.5 kW	DTC2540240L
25	4 NC	240 V AC	36	25 A / 5.4 kW	8.5 A / 1.5 kW	DTC2504240L
40	4 NO	240 V AC	88	40 A / 8.4 kW	15 A / 2.4 kW	DTC4040240L
63	4 NO	240 V AC	88	63 A / 13 kW	25 A / 3.8 kW	DTC6340240L



## DIN-T Add-on Modules

# DIN-T Pushbuttons and Pilot Lights



- ✓ Modular size
- ✓ DIN rail mounting
- ✓ Terminal protection IP 20
- ✓ Contacts 16 amp rating @250 V AC



## Connection

### Pushbuttons

#### Contacts

1 x (N/O + N/C)



1 x N/O + LAMP



## Design Considerations

### Notes:

1. For illuminated pushbuttons, order lens separately, 240 V lamp built-in and cannot be changed
2. For Pilot light bases order lens and lamp separately

## Dimensions

### Pushbuttons - Aster

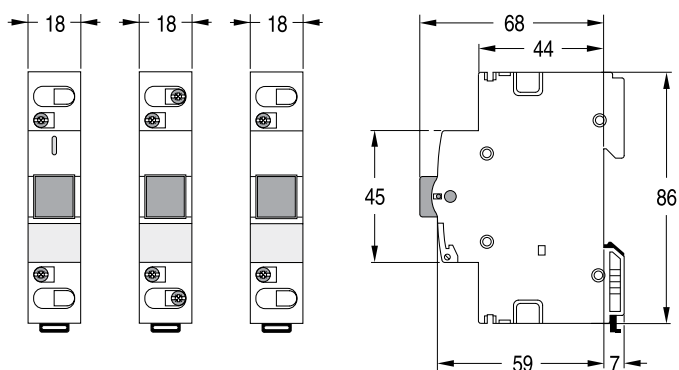

### Indication lamp - Aster

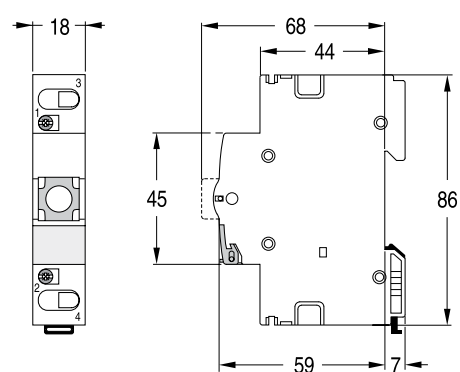

#### Item Description

#### Catalogue No.

DIN Pushbutton Illuminated 1 N/O DTPB10L

DIN Pushbutton N/O + N/C DTPB11

DIN Pilot Light Base DTPLB

DIN Pilot Light LED E10 Blue DTPLEDBL

DIN Pilot Light LED E10 Clear DTPLEDCL

DIN Pilot Light LED E10 Green DTPLEDGR

DIN Pilot Light LED E10 Orange DTPLEDOR

DIN Pilot Light LED E10 Red DTPLEDRD

Lamp 24 V DTPLL24

Lamp 240 V DTPLL240

Lens Clear DTPLLCL

Lens Green DTPLLGR

Lens Orange DTPLLOR

Lens Red DTPLLRD



## Technical Data

<b>Nominal Rated Current</b>	<b>16 A</b>	
<b>Usable As Mains Disconnect Switch</b>	No	
<b>Nominal Breaking Capacity at 415 V, <math>\cos \varphi = 0.95</math></b>	-	
<b>Nominal Breaking Capacity at 415 V, <math>\cos \varphi = 0.65</math></b>	-	
<b>Nominal Voltage Single Pole Devices</b>	240 V	
<b>Nominal Voltage Multi-pole Devices</b>	415 V	
<b>Maximum Allowed Current During Less Than 1s</b>	-	
<b>Mechanical Service Life (Complete on-off-cycle)</b>	> 20000	
<b>Electrical Service Life, <math>\cos \varphi = 0.95</math>, <math>U_n</math> and <math>I_n</math></b>	> 20000	> 5000
<b>Short-circuit Resistance With Upfront Fuses</b>	4.5 kA (nominal)	
<b>Short-circuit Resistance Without Upfront Fuses</b>	3 kA (nominal)	
<b>Protection Degree</b>	IP 20	
<b>Screws</b>	Pozidrive 1	
<b>Terminal Capacity:</b>	<b>Min.</b>	1 x 1.5 mm <sup>2</sup>
	<b>Max.</b>	1 x 10 mm <sup>2</sup>

## | DIN-T Add-on Modules

# DIN-T Motor Operator



- ✓ Suits DIN-T 6, 10, 15, DC and E6
- ✓ Manual operation is possible
- ✓ Field fittable, left or right mounting
- ✓ Manual and electrical reset
- ✓ Motor must be reset before tripped MCB/RCD can be closed
- ✓ Impulse switch on < 50 ms
- ✓ Inbuilt auxiliary / alarm contacts
- ✓ Padlockable in OFF position
- ✓ Silent operation
- ✓ Stack on left or right side up to 4 auxiliary contacts
- ✓ Can operate as a stand-alone device switching accessories only

## | Application

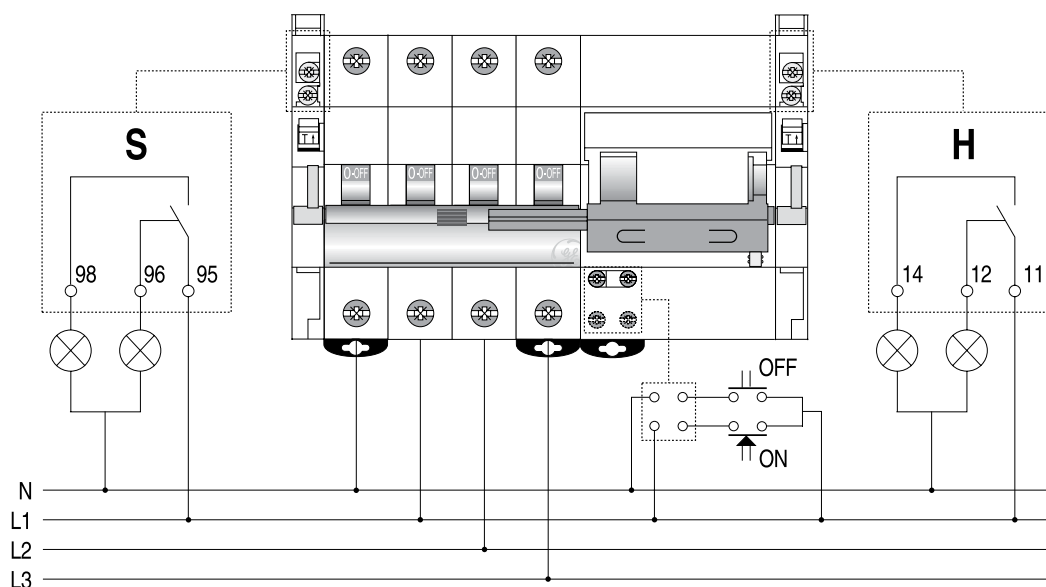

DIN profile motor operator allowing remote operation of DIN-T circuit protection devices.

## Connection

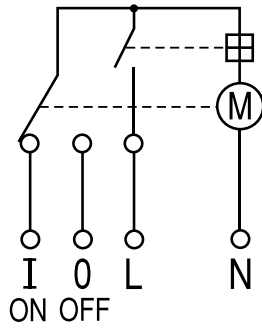

## Design Considerations

- 1, 2 and 3 pole DIN-T 6, 10 and 15 MCBs
- 2 and 4 pole DIN-Safe safety switches (Fits to right side only on 2 P RCBO and 2 / 4P RCCB)
- 2 pole DIN-Safe MCBs (combined MCB / RCD)
- Not suitable for DIN-T10H MCBs

## Dimensions

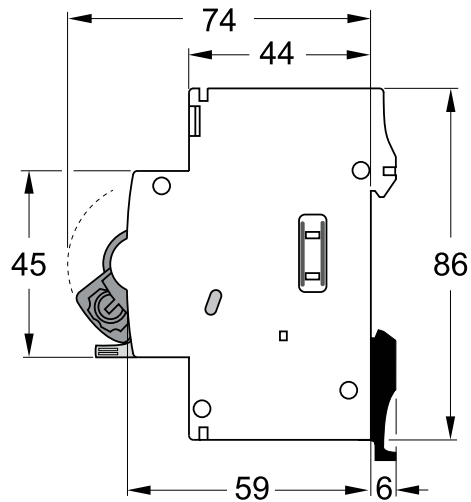
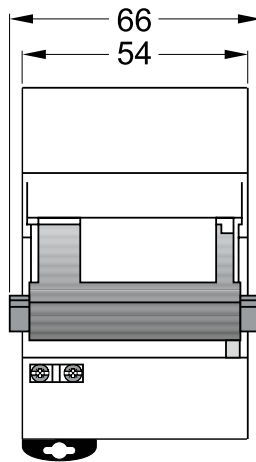

Item Description

Catalogue No.

DIN Motor Driver 230 V AC suits DIN-T

DTMD240VAC





## Technical Data

Nominal Voltage AC	V	230 ± 10 %
Frequency	Hz	50
Power Consumption	VA	35
Closing Time	ms	<500
Opening Time	ms	<200
Impulse Time to Open	ms	>50
Impulse Time to Close	ms	>50
Working Temperature	°C	-25 up to +55
Electrical Life	Ops	10,000
Terminal Capacity	Rigid Cable	mm <sup>2</sup> 1 - 2.5
	Flexible Cable	mm <sup>2</sup> 0.75 - 2.5
Terminal Capacity for 2 Rigid Cables	mm <sup>2</sup>	2 x 1.5
Torque	Nm	2
Width	54 mm (motor only)	
Protection Degree of Terminals	IP 20	
Sealing Handle Prevents	In 0 Position	Closing manually or electrically the breaker
	In 1 Position	Setting out of service
Automatic Stop Power Feature Built-In	Power consumption only when closing or opening the MCB electrically	
Current I <sub>n</sub>	0.13 A	
Time Between Successive Opening & Closing	Minimum 1 sec	
Time of Successive Closing of MCB Contacts	0.3 sec	
Weight	(g) 380	

## DIN-T Add-on Modules

# DIN-T Impulse Switch



- ✓ Standard IEC 60669-2-2
- ✓ Visible indication of contact position
- ✓ Terminal Protection IP 20
- ✓ Terminal Screws are captive with groove and cross head
- ✓ 16 amp 240 V AC contact rating
- ✓ 32 amp unit option



## Application

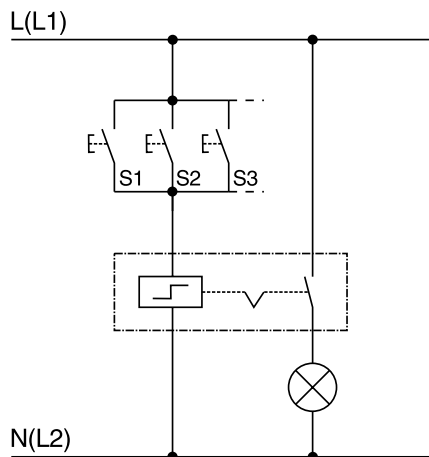

DIN profile electromechanical switch typically used for controlling lighting and heating equipment.

## Dimensions

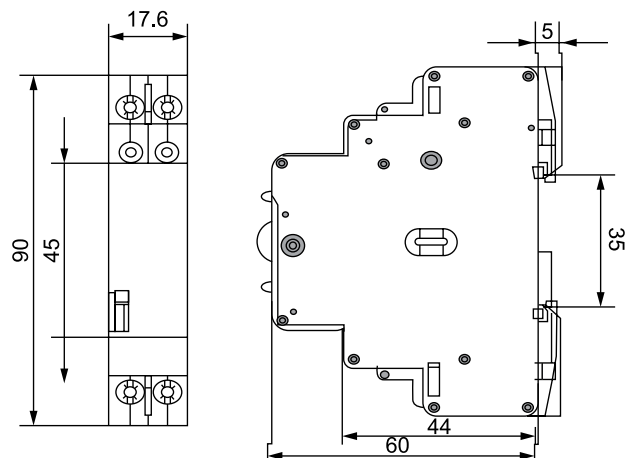



Item Description	Catalogue No.
DIN-T Impulse Switch 16 A 1P NO 12 V AC	DTIS1012VAC
DIN-T Impulse Switch 16 A 1P NO 240 V AC	DTIS10240VAC
DIN-T Impulse Switch 16 A 1P NO 24 V AC	DTIS1024VAC
DIN-T Impulse Switch 16 A 1P NO 48 V AC	DTIS1048VAC
DIN-T Impulse Switch 16 A 1P NO+NC 12 V AC	DTIS1112VAC
DIN-T Impulse Switch 16 A 1P NO+NC 240 V AC	DTIS11240VAC
DIN-T Impulse Switch 16 A 1P NO+NC 24 V AC	DTIS1124VAC
DIN-T Impulse Switch 16 A 1P NO+NC 48 V AC	DTIS1148VAC
DIN-T Impulse Switch 16 A 2P NO 12 V AC	DTIS2012VAC
DIN-T Impulse Switch 16 A 2P NO 240 V AC	DTIS20240VAC
DIN-T Impulse Switch 16 A 2P NO 24 V AC	DTIS2024VAC
DIN-T Impulse Switch 16 A 2P NO 48 V AC	DTIS2048VAC



## Technical Data

In Accordance With IEC 60669-2-2 Contacts / Load Circuit

**Rated Switching Capacity** **16 A**

### Contacts

Switching Capacity	16 A / 250 V; 16 A / 440 V	
Incandescent Lamp Load (40 to 200 W lamps)	3000 W	
Fluorescent Lamp Load, Surge Compensation	3000 VA	
Fluorescent Lamp Load, Parallel Compensation	2500 VA	
Fluorescent Lamp Load, No Compensation	1800 VA	
DC Switching Capacity (30 V DC)	16 A	
Minimum Contact Load	5 V / 2 VA	
Maximum Switching Frequency	900 / h	
Mechanical Service Life	2 x 10 <sup>6</sup>	
Electrical Service Life, cos φ = 1	2 x 10 <sup>5</sup>	
Screws	Pozidrive 1	
Terminal Capacity:	Min.	1 mm <sup>2</sup>
	Max.	10 mm <sup>2</sup>

### Magnetic Control System

Control Voltage Range	0.9 ... 1.1 x U <sub>n</sub>	
Coil Pick Up Power	18 VA	
Maximum Continuous Time of Coil Excitation	1 h	
Minimum Duration of Command Impulse / Pause	50 ms / -	
Operating Temperature Range	-25 / +55 °C	
Maximum Number of Illuminated Pushbuttons (0.6 mA)	- Without Parallel Compensating Capacitor	4
	1 Compensator	30
	2 Compensator	50
Maximum Coil Power Loss at U <sub>n</sub> and I <sub>n</sub>	9 VA	
Number of Impulses per Hour	900	
Screws	Pozidrive 1	
Terminal Capacity:	Min.	1 mm <sup>2</sup>
	Max.	4 mm <sup>2</sup>

## DIN-T Add-on Modules

# DIN-T Hour Run Counter



- ✓ Two module width
- ✓ DIN rail mounting
- ✓ With synchronous motor drive
- ✓ Permanent visual display, non resettable
- ✓ Electromechanical device

CE

## Connection

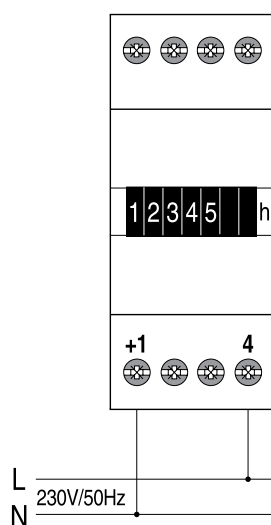

## Dimensions

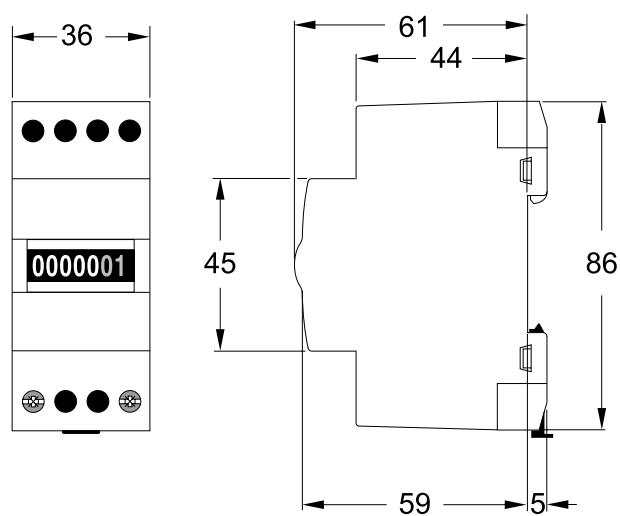



Item Description	Catalogue No.
DIN-T Hour Run Counter	DTHR

## Technical Data

Rated Voltage	(V AC / Hz)	220 - 240 / 50
Consumption	(mA)	10
Counter Capacity	(Hours)	99,999.99
Terminal Protection Degree	-	IP 20
Terminal Capacity	(mm <sup>2</sup> )	1 x 2.5 or 2 x 1.5
Ambient Temperature	(°C)	-10 to +55

Catalogue Number	Page	Catalogue Number	Page	Catalogue Number	Page
<b>D</b>					
DCLD6	107,147	DSRCBH10100AD	113	DSRCD24030A	130
DINT10HHS	170	DSRCBH1010A	113	DSRCD24030AI	130
DINT10HTC	106,146	DSRCBH1010AD	113	DSRCD24030F	130
DINTMS1001	160	DSRCBH1030A	113	DSRCD263100B	130
DINTMS1002	160	DSRCBH1030AD	113	DSRCD26330A	130
DINTMS1003	160	DSRCBH16100A	113	DSRCD26330AI	130
DINTMS631	160	DSRCBH16100AD	113	DSRCD26330B	130
DINTMS632	160	DSRCBH1610A	113	DSRCD280100A	130
DINTMS633	160	DSRCBH1610AD	113	DSRCD28030A	130
DINTMS801	160	DSRCBH1630A	113	DSRCD410030A	130
DINTMS802	160	DSRCBH1630AD	113	DSRCD44030A	130
DINTMS803	160	DSRCBH20100A	113	DSRCD44030AI	130
DINTSHT110415U	162	DSRCBH20100AD	113	DSRCD44030F	130
DINTSHT2460U	162	DSRCBH2010A	113	DSRCD463100A	130
DSRCB0610A	124	DSRCBH2010AD	113	DSRCD463100B	130
DSRCB0630AI	124	DSRCBH2030A	113	DSRCD463300B	130
DSRCB0630P	124	DSRCBH2030AD	113	DSRCD46330A	130
DSRCB10100A	124	DSRCBH25100A	113	DSRCD46330AI	130
DSRCB1010A	124	DSRCBH25100AD	113	DSRCD46330B	130
DSRCB1030A	124	DSRCBH2510A	113	DSRCD480100A	130
DSRCB1030AI	124	DSRCBH2510AD	113	DSRCDE24030	139
DSRCB1030P	124	DSRCBH2530A	113	DSRCDE26330	139
DSRCB16100A	124	DSRCBH2530AD	113	DSRCDE44030	139
DSRCB1610A	124	DSRCBH32100A	113	DSRCDE46330	139
DSRCB1630A	124	DSRCBH32100AD	113	DSRCM321001PN	134
DSRCB1630AI	124	DSRCBH3210A	113	DSRCM321003PN	134
DSRCB1630P	124	DSRCBH3210AD	113	DSRCM323001PN	134
DSRCB20100A	124	DSRCBH3230A	113	DSRCM323003PN	134
DSRCB2010A	124	DSRCBH3230AD	113	DSRCM32301PN	134
DSRCB2030A	124	DSRCBH40100A	113	DSRCM32303PN	134
DSRCB2030AI	124	DSRCBH40100AD	113	DSRCM631001PN	134
DSRCB2030P	124	DSRCBH4010A	113	DSRCM631003P	135
DSRCB2530A	124	DSRCBH4010AD	113	DSRCM631003PN	135
DSRCB2530AI	124	DSRCBH4030A	113	DSRCM633001PN	134
DSRCB2530P	124	DSRCBH4030AD	113	DSRCM633003P	135
DSRCB3230A	124	DSRCBHTC	106,146	DSRCM633003PN	135
DSRCB3230AI	124	DSRCBS0610CAN	119	DSRCM63301PN	134
DSRCB3230P	124	DSRCBS0630CAN	119	DSRCM63303P	135
DSRCB4030A	124	DSRCBS1010CAN	119	DSRCM63303PN	135
DSRCB4030AI	124	DSRCBS1030CAN	119	DTAUXAL	170
DSRCB4030P	124	DSRCBS1610CAN	119	DTAUXALG	170
DSRCBH06100A	113	DSRCBS1630CAN	119	DTC2002240	178
DSRCBH06100AD	113	DSRCBS2010CAN	119	DTC2011240	178
DSRCBH0610A	113	DSRCBS2030CAN	119	DTC202024	178
DSRCBH0610AD	113	DSRCBS2510CAN	119	DTC2020240	178
DSRCBH0630A	113	DSRCBS2530CAN	119	DTC2020240L	187
DSRCBH0630AD	113	DSRCBS3210CAN	119	DTC202024L	187
DSRCBH10100A	113	DSRCBS3230CAN	119	DTC2404240	178
		DSRCBSAX	170	DTC244012	178
		DSRCBSAXAL	170	DTC244024	178
		DSRCBSAXALG	170	DTC2440240	178
		DSRCD240100A	130	DTC2504240L	187

Catalogue Number	Page	Catalogue Number	Page	Catalogue Number	Page
DTC254012L	187	DTCB10205C	81	DTCB10320B	82
DTC2540240L	187	DTCB10205D	81	DTCB10320C	82
DTC404024	178	DTCB10206B	81	DTCB10320D	82
DTC4040240	178	DTCB10206C	81	DTCB10325B	82
DTC4040240L	187	DTCB10206D	81	DTCB10325C	82
DTC634024	178	DTCB10210B	81	DTCB10325D	82
DTC6340240	178	DTCB10210C	81	DTCB10332B	82
DTC6340240L	187	DTCB10210D	81	DTCB10332C	82
DTCB10101C	81	DTCB10213B	81	DTCB10332D	82
DTCB10101D	81	DTCB10213C	81	DTCB10340B	82
DTCB10102C	81	DTCB10213D	81	DTCB10340C	82
DTCB10102D	81	DTCB10216B	81	DTCB10340D	82
DTCB10103C	81	DTCB10216C	81	DTCB10350B	82
DTCB10104C	81	DTCB10216D	81	DTCB10350C	82
DTCB10104D	81	DTCB10220B	81	DTCB10350D	82
DTCB10105C	81	DTCB10220C	81	DTCB10363B	82
DTCB10105D	81	DTCB10220D	81	DTCB10363C	82
DTCB10106B	81	DTCB10225B	81	DTCB10363D	82
DTCB10106C	81	DTCB10225C	81	DTCB10401C	82
DTCB10106D	81	DTCB10225D	81	DTCB10402C	82
DTCB10110B	81	DTCB10232B	81	DTCB10403C	82
DTCB10110C	81	DTCB10232C	81	DTCB10404C	82
DTCB10110D	81	DTCB10232D	81	DTCB10404D	82
DTCB10113C	81	DTCB10240B	81	DTCB10406C	82
DTCB10113D	81	DTCB10240C	81	DTCB10406D	82
DTCB10116B	81	DTCB10240D	81	DTCB10410C	82
DTCB10116C	81	DTCB10250B	81	DTCB10410D	82
DTCB10116D	81	DTCB10250C	81	DTCB10413C	82
DTCB10120B	81	DTCB10250D	81	DTCB10413D	82
DTCB10120C	81	DTCB10263B	81	DTCB10416B	82
DTCB10120D	81	DTCB10263C	81	DTCB10416C	82
DTCB10125B	81	DTCB10263D	81	DTCB10416D	82
DTCB10125C	81	DTCB10301C	82	DTCB10420B	82
DTCB10125D	81	DTCB10301D	82	DTCB10420C	82
DTCB10132B	81	DTCB10302C	82	DTCB10420D	82
DTCB10132C	81	DTCB10302D	82	DTCB10425C	82
DTCB10132D	81	DTCB10304C	82	DTCB10425D	82
DTCB10140B	81	DTCB10304D	82	DTCB10432C	82
DTCB10140C	81	DTCB10305C	82	DTCB10432D	82
DTCB10140D	81	DTCB10305D	82	DTCB10440C	82
DTCB10150B	81	DTCB10306B	82	DTCB10440D	82
DTCB10150C	81	DTCB10306C	82	DTCB10450C	82
DTCB10150D	81	DTCB10306D	82	DTCB10450D	82
DTCB10163B	81	DTCB10310B	82	DTCB10463C	82
DTCB10163C	81	DTCB10310C	82	DTCB10463D	82
DTCB10163D	81	DTCB10310D	82	DTCB10H1100B	90
DTCB10201C	81	DTCB10313B	82	DTCB10H1100C	90
DTCB10201D	81	DTCB10313C	82	DTCB10H1100D	90
DTCB10202C	81	DTCB10313D	82	DTCB10H1125B	90
DTCB10202D	81	DTCB10316B	82	DTCB10H1125C	90
DTCB10204C	81	DTCB10316C	82	DTCB10H1125D	90
DTCB10204D	81	DTCB10316D	82	DTCB10H180B	90



Catalogue Number	Page	Catalogue Number	Page	Catalogue Number	Page
DTCB10H180C	90	DTCB15316C	97	DTCB6216D	51
DTCB10H180D	90	DTCB15320C	97	DTCB6220C	51
DTCB10H2100B	90	DTCB15325C	97	DTCB6220D	51
DTCB10H2100C	90	DTCB15332C	97	DTCB6225C	51
DTCB10H2100D	90	DTCB15340C	97	DTCB6225D	51
DTCB10H2125B	90	DTCB15350C	97	DTCB6232C	51
DTCB10H2125C	90	DTCB15363C	97	DTCB6232D	51
DTCB10H2125D	90	DTCB15406C	97	DTCB6240C	51
DTCB10H280B	90	DTCB15410C	97	DTCB6240D	51
DTCB10H280C	90	DTCB15413C	97	DTCB6250C	51
DTCB10H280D	90	DTCB15416C	97	DTCB6250D	51
DTCB10H3100B	90	DTCB15420C	97	DTCB6263C	51
DTCB10H3100C	90	DTCB15425C	97	DTCB6263D	51
DTCB10H3100D	90	DTCB15432C	97	DTCB6302C	51
DTCB10H3125B	90	DTCB15440C	97	DTCB6302D	51
DTCB10H3125C	90	DTCB15450C	97	DTCB6304C	51
DTCB10H3125D	90	DTCB15463C	97	DTCB6304D	51
DTCB10H380B	90	DTCB6102C	51	DTCB6306C	51
DTCB10H380C	90	DTCB6102D	51	DTCB6306D	51
DTCB10H380D	90	DTCB6104C	51	DTCB6310C	51
DTCB10H4100B	90	DTCB6104D	51	DTCB6310D	51
DTCB10H4100C	90	DTCB6106C	51	DTCB6313C	51
DTCB10H4100D	90	DTCB6106D	51	DTCB6313D	51
DTCB10H4125B	90	DTCB6110C	51	DTCB6316C	51
DTCB10H4125C	90	DTCB6110D	51	DTCB6316D	51
DTCB10H4125D	90	DTCB6113C	51	DTCB6320C	51
DTCB10H480B	90	DTCB6113D	51	DTCB6320D	51
DTCB10H480C	90	DTCB6116C	51	DTCB6325C	51
DTCB10H480D	90	DTCB6116D	51	DTCB6325D	51
DTCB15106C	96	DTCB6120C	51	DTCB6332C	51
DTCB15110C	96	DTCB6120D	51	DTCB6332D	51
DTCB15113C	96	DTCB6125C	51	DTCB6340C	51
DTCB15116C	96	DTCB6125D	51	DTCB6340D	51
DTCB15120C	96	DTCB6132C	51	DTCB6350C	51
DTCB15125C	96	DTCB6132D	51	DTCB6350D	51
DTCB15132C	96	DTCB6140C	51	DTCB6363C	51
DTCB15140C	96	DTCB6140D	51	DTCB6363D	51
DTCB15150C	96	DTCB6150C	51	DTCBD61102C	59
DTCB15163C	96	DTCB6150D	51	DTCBD61104C	59
DTCB15206C	96	DTCB6163C	51	DTCBD61106C	59
DTCB15210C	96	DTCB6163D	51	DTCBD61110C	59
DTCB15213C	96	DTCB6202C	51	DTCBD61116C	59
DTCB15216C	96	DTCB6202D	51	DTCBD61120C	59
DTCB15220C	96	DTCB6204C	51	DTCBD6202C	59
DTCB15225C	96	DTCB6204D	51	DTCBD6204C	59
DTCB15232C	96	DTCB6206C	51	DTCBD6206C	59
DTCB15240C	96	DTCB6206D	51	DTCBD6210C	59
DTCB15250C	96	DTCB6210C	51	DTCBD6216C	59
DTCB15263C	96	DTCB6210D	51	DTCBD6220C	59
DTCB15306C	97	DTCB6213C	51	DTCBD6225C	59
DTCB15310C	97	DTCB6213D	51	DTCBD6232C	59
DTCB15313C	97	DTCB6216C	51	DTCBD6240C	59

Catalogue Number	Page	Catalogue Number	Page	Catalogue Number	Page
DTCBD6302C	60	DTCBE6132C	67	DTPLEDCL	189
DTCBD6304C	60	DTCBE6140C	67	DTPLEDGR	189
DTCBD6306C	60	DTCBE6150C	67	DTPLEDOR	189
DTCBD6310C	60	DTCBE6163C	67	DTPLEDRD	189
DTCBD6316C	60	DTCBE6306C	67	DTPLL24	189
DTCBD6320C	60	DTCBE6310C	67	DTPLL240	189
DTCBD6325C	60	DTCBE6316C	67	DTPLLCL	189
DTCBD6332C	60	DTCBE6320C	67	DTPLLGR	189
DTCBD6340C	60	DTCBE6325C	67	DTPLLOR	189
DTCBD6402C	60	DTCBE6332C	67	DTPLLRD	189
DTCBD6404C	60	DTCBE6340C	67	DTSHT110415V	162
DTCBD6406C	60	DTCBE6350C	67	DTSHT2460V	162
DTCBD6410C	60	DTCBE6363C	67	DTSP	106,146
DTCBD6416C	60	DTCBSEALPLATE	110,150	DTTAX16PN3	19,48,101
DTCBD6420C	60	DTCF35	104,144	DTTAX25PN	104,144
DTCBD6425C	60	DTCS3212	175	DTTAX25SP	105,145
DTCBD6432C	60	DTCS3213	175	DTTAX50PN	105,145
DTCBD6440C	60	DTCS3222	175	DTTC35	106,146
DTCBDC101C	74	DTCS3223	175	DTTC5	106,146
DTCBDC102C	74	DTHR	198	DTTLT25PN2	19,48
DTCBDC104C	74	DTIS1012VAC	195	DTTLT35LPN	105,145
DTCBDC105C	74	DTIS10240VAC	195	DTTLT35PN	105,145
DTCBDC106C	74	DTIS1024VAC	195	DTTLT35SP	105,145
DTCBDC110C	74	DTIS1048VAC	195	DTUVT12VDC	166
DTCBDC116C	74	DTIS1112VAC	195	DTUVT240VAC	166
DTCBDC120C	74	DTIS11240VAC	195	DTUVT24VDC	166
DTCBDC125C	74	DTIS1124VAC	195		
DTCBDC132C	74	DTIS1148VAC	195		
DTCBDC140C	74	DTIS2012VAC	195		
DTCBDC150C	74	DTIS20240VAC	195		
DTCBDC163C	74	DTIS2024VAC	195		
DTCBDC201C	74	DTIS2048VAC	195		
DTCBDC202C	74	DTLCM	109,149	IBC108P	101,141
DTCBDC204C	74	DTLD	19,48,107,147	IBC112P	17,46,101,141
DTCBDC206C	74	DTLDH	107,147	IBC115P	17,46,101,141
DTCBDC210C	74	DTLDM	106,146	IBC118P	17,46,101,141
DTCBDC216C	74	DTLLA	108,148	IBC121P	101,141
DTCBDC220C	74	DTLLA10H	108,148	IBC155P	101,141
DTCBDC225C	74	DTLLAB	108,148	IBCEC1	18,47
DTCBDC232C	74	DTLLABRH	108,148	IBD213P	17,46
DTCBDC240C	74	DTLLABULK	108,148	IBD218P	17,46
DTCBDC250C	74	DTLLARH	108,148	IBD255P	17,46
DTCBDC263C	74	DTLLARHBULK	108,148	IBD312P	103,143
DTCBDC410B	74	DTLLB	109,149	IBD355P	103,143
DTCBDC416B	74	DTLPPF	109,149	IBD4552P	103,143
DTCBDC420B	74	DTMD240VAC	192	IBD4554P	103,143
DTCBDC440B	74	DTPB10L	189	IBDEC2	18,47
DTCBE6106C	67	DTPB11	189	IBDEC4	18,47
DTCBE6110C	67	DTPBS	110,150	ICL102	102,142
DTCBE6116C	67	DTPF	19,48	ICL121F	17,46
DTCBE6120C	67	DTPLB	189	ICL123	102,142
DTCBE6125C	67	DTPLEDBL	189	ICL153	102,142
				ICL181F	17,46
				ICL183	102,142

Catalogue Number	Page
ICL213	102, 142
ICL41F	17, 46
ICL561F	17, 46
ICL562	102, 142
ICL563A	102, 142
ICL564	102, 142
ICL573	102, 142
ICL573F	17, 46
ICL62	102, 142
ICLEC23	103, 143
ICLEC4	103, 143
ICLTOC	104, 144

## L

LOCTITE480	110, 150
------------	----------

## M

M6RCBD0610CAN	36
M6RCBD0630CAN	36
M6RCBD1010CAN	36
M6RCBD1030CAN	36
M6RCBD1610CAN	36
M6RCBD1630CAN	36
M6RCBD2010CAN	36
M6RCBD2030CAN	36
M6RCBD2510CAN	36
M6RCBD2530CAN	36
M6RCBD3210CAN	36
M6RCBD3230CAN	36
M6RCBS0610CAN	31
M6RCBS0630CAN	31
M6RCBS1010CAN	31
M6RCBS1030CAN	31
M6RCBS1610CAN	31
M6RCBS1630CAN	31
M6RCBS2010CAN	31
M6RCBS2030CAN	31
M6RCBS2510CAN	31
M6RCBS2530CAN	31
M6RCBS3210CAN	31
M6RCBS3230CAN	31
MOD6106	12
MOD6110	12
MOD6116	12
MOD6120	12
MOD6125	12
MOD6132	12
MOD6140	12

Catalogue Number	Page
MOD6150	12
MOD6163	12
MOD6206	12
MOD6210	12
MOD6216	12
MOD6220	12
MOD6225	12
MOD6232	12
MOD6240	12
MOD6250	12
MOD6263	12
MOD6306	12
MOD6310	12
MOD6316	12
MOD6320	12
MOD6325	12
MOD6332	12
MOD6340	12
MOD6350	12
MOD6363	12
MOD6MS1100	16, 45
MOD6MS180	16, 45
MOD6MS2100	16, 45
MOD6MS3100	16, 45
MOD6RCBO11030AL	26
MOD6RCBO11630AL	26
MOD6RCBO12030AL	26
MOD6RCBO12530AL	26
MOD6RCBO13230AL	26
MOD6RCBO20610A	41
MOD6RCBO21010A	41
MOD6RCBO21030	41
MOD6RCBO21030A	41
MOD6RCBO21610A	41
MOD6RCBO21630	41
MOD6RCBO21630A	41
MOD6RCBO22010A	41
MOD6RCBO22030	41
MOD6RCBO22030A	41
MOD6RCBO22530	41
MOD6RCBO22530A	41
MOD6RCBO23230	41
MOD6RCBO23230A	41
MOD6RCBO24030A	41
MOD6RCCB24030	22
MOD6RCCB24030A	22
MOD6RCCB26330	22
MOD6RCCB26330A	22
MOD6RCCB44030	22
MOD6RCCB44030A	22
MOD6RCCB46330	22
MOD6RCCB46330A	22

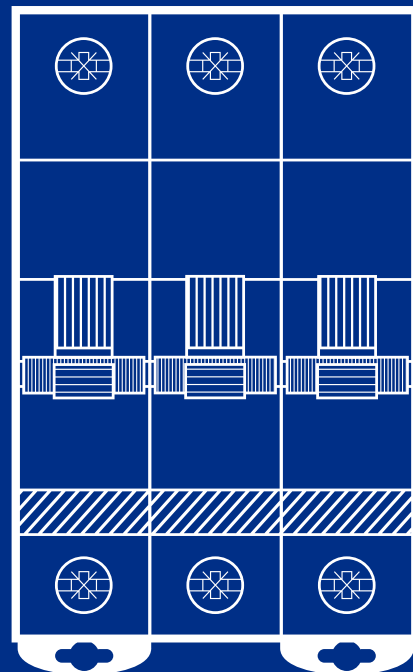
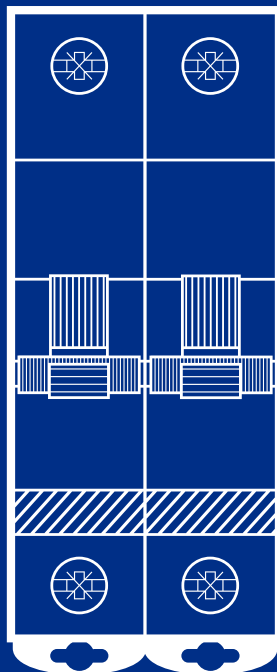
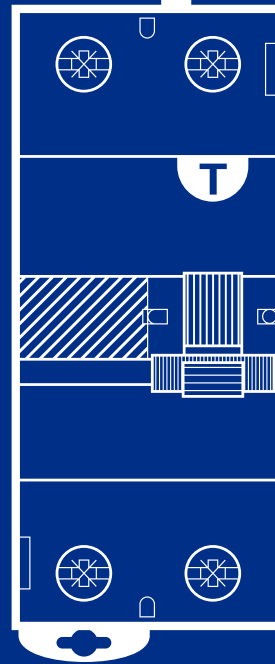
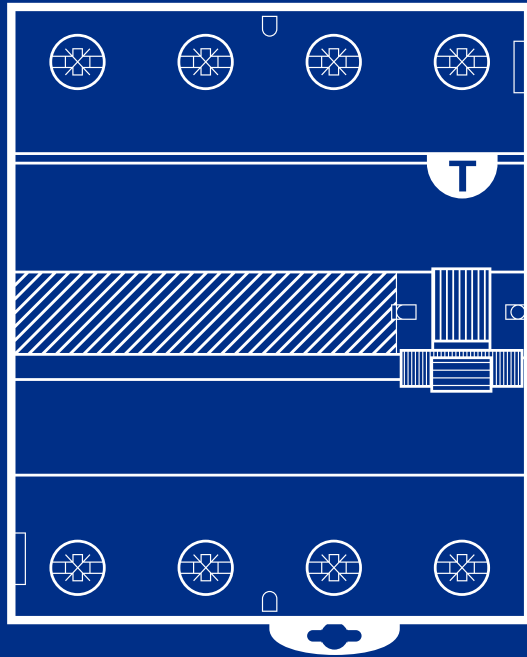

**AUSTRALIA**

nhp.com.au  
 SALES 1300 NHP NHP  
 sales@nhp.com.au

**NEW ZEALAND**

nhp-nz.com  
 SALES 0800 NHP NHP  
 sales@nhp-nz.com

**NHP Electrical Engineering Products**

A.B.N. 84 004 304 812  
 NPLCAU19 V.2020-12-02  
 © Copyright NHP 2020